

9. Remove and discard the rear shock absorber upper bolts and remove the rear shock absorber.

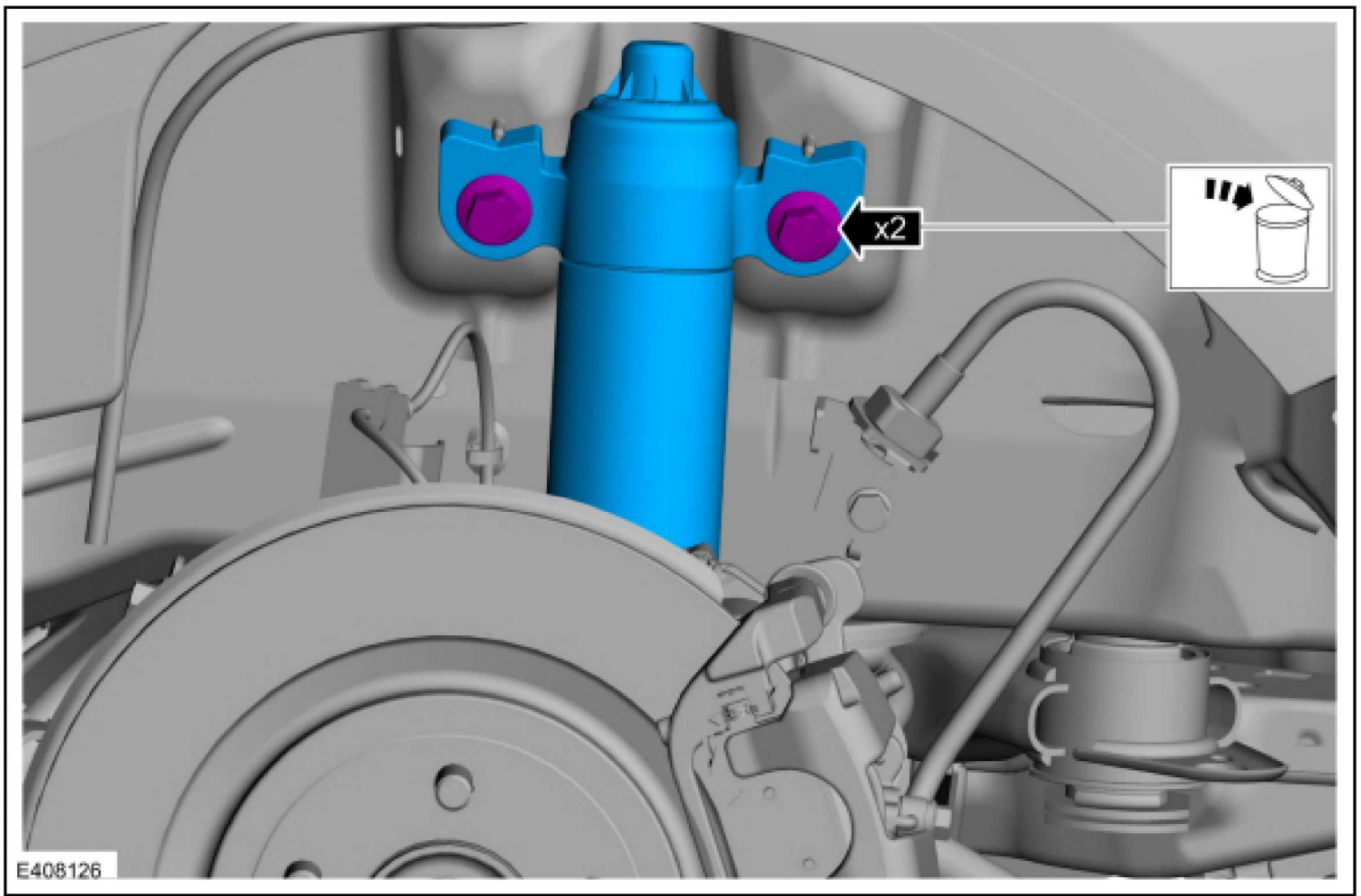

Installation

Vehicles equipped with dynamic suspension

1. **NOTE:** *This step is only necessary when installing a new component.*

NOTE: *Use the hex-holding feature to prevent the shock absorber rod from turning while installing the shock absorber rod nut.*

Install the new rear shock absorber rod nut.
Torque : 22 lb.ft (30 Nm)

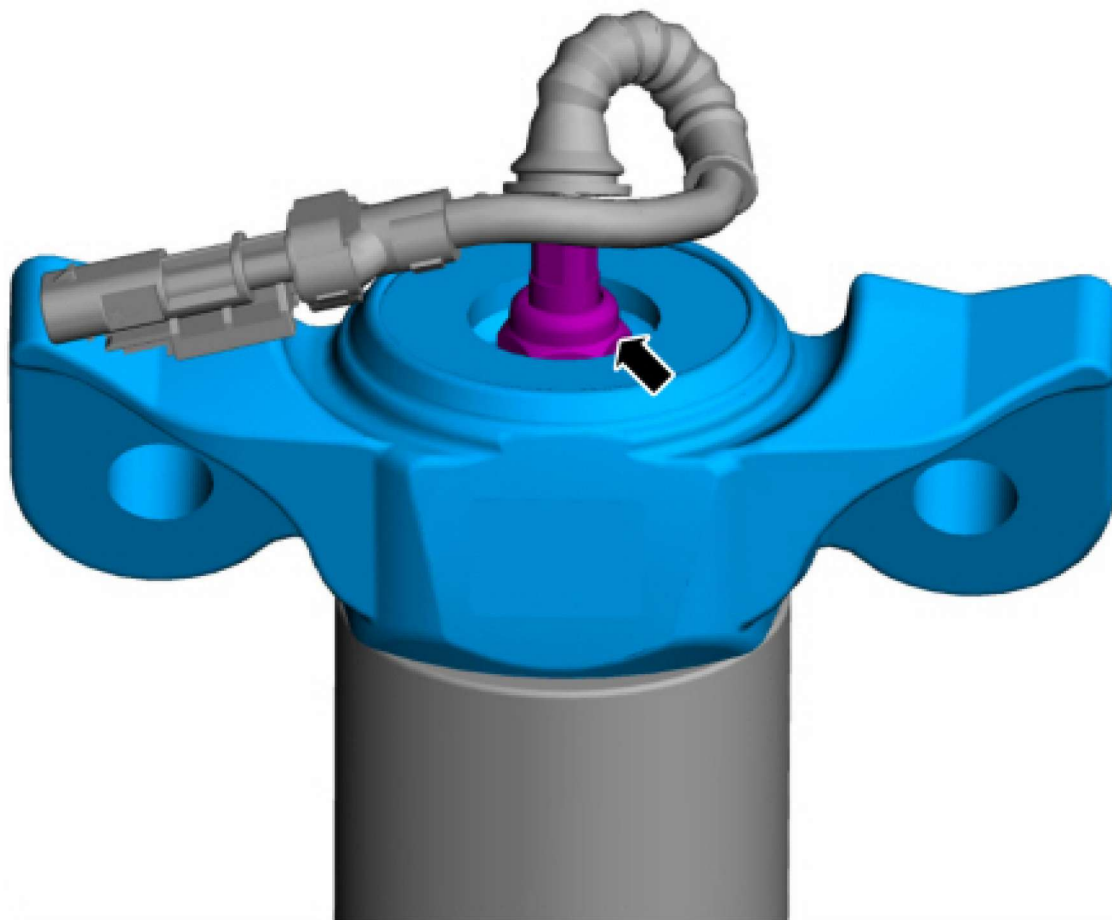

E313434

2. **NOTE:** *This step is only necessary when installing a new component.*

NOTE: *If equipped.*

Install the rear shock absorber rod nut cap.

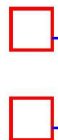

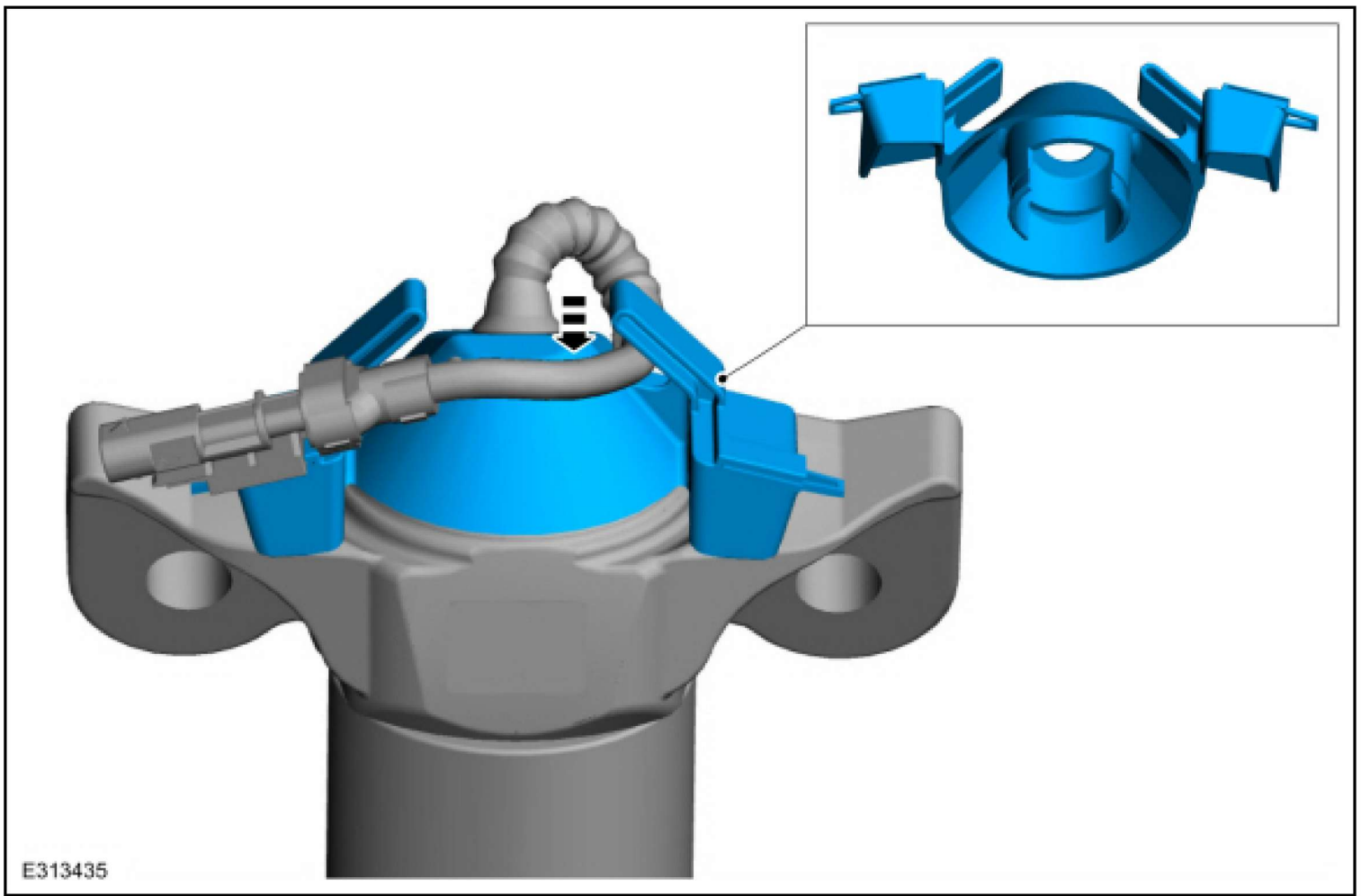

3. Install the rear shock absorber and install the new rear shock absorber lower bolts.
Torque : 41 lb.ft (55 Nm)



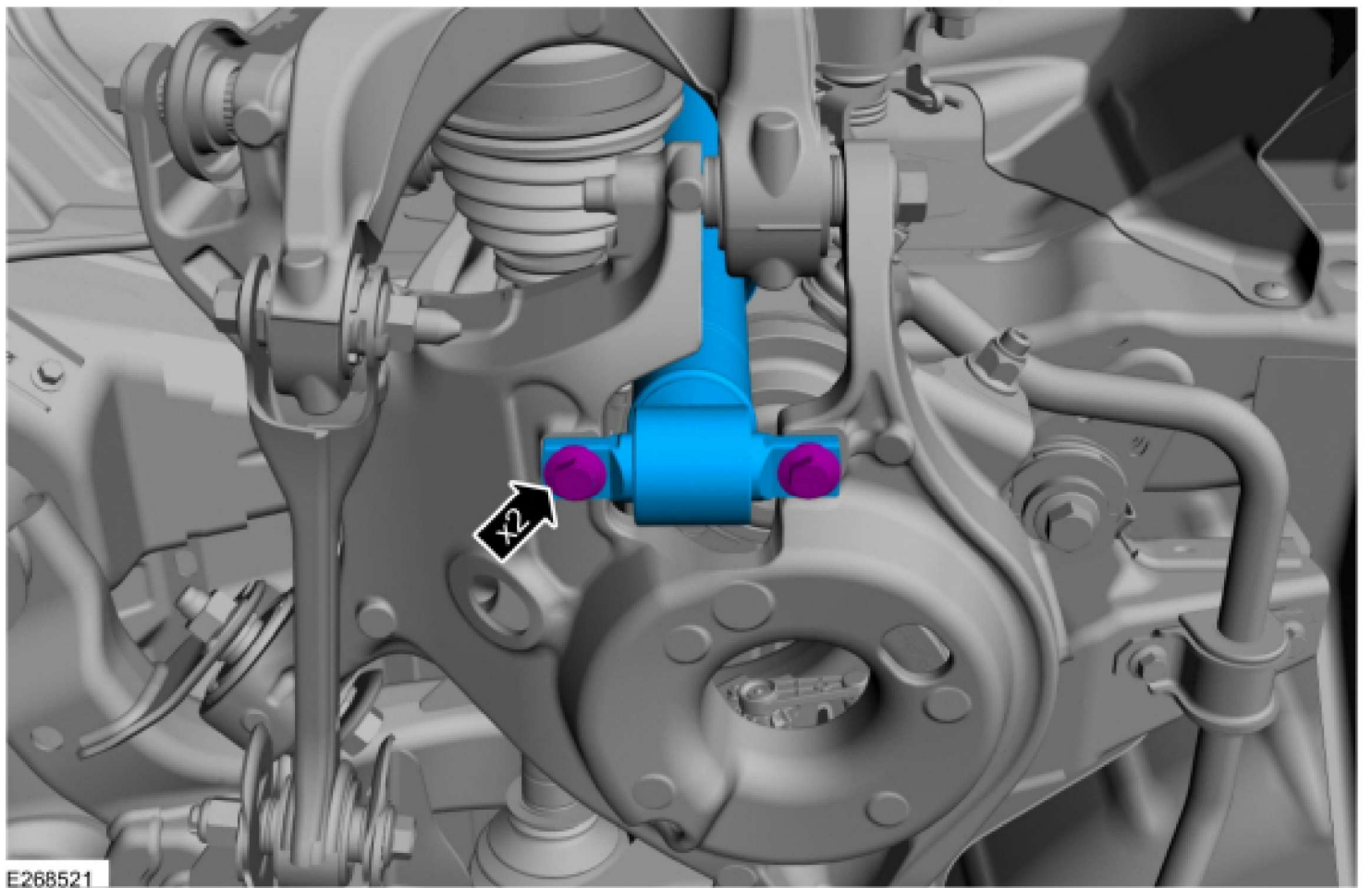

1. Compress the rear shock absorber and align the rear shock absorber upper mount under the body alignment pins.
2. Install the new rear shock absorber upper bolts.
Torque : 76 lb.ft (103 Nm)

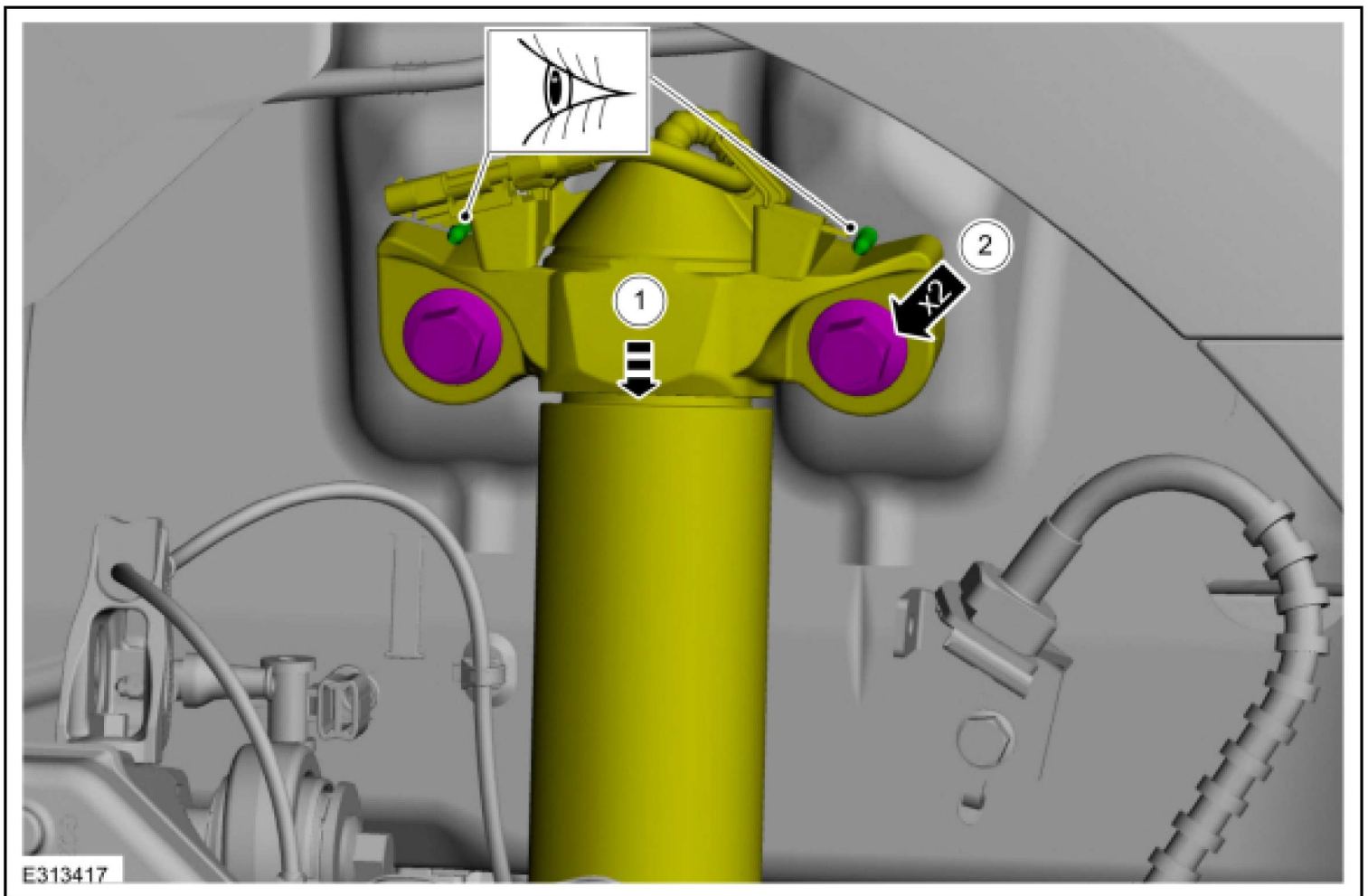

5. Connect the rear shock absorber electrical connector.

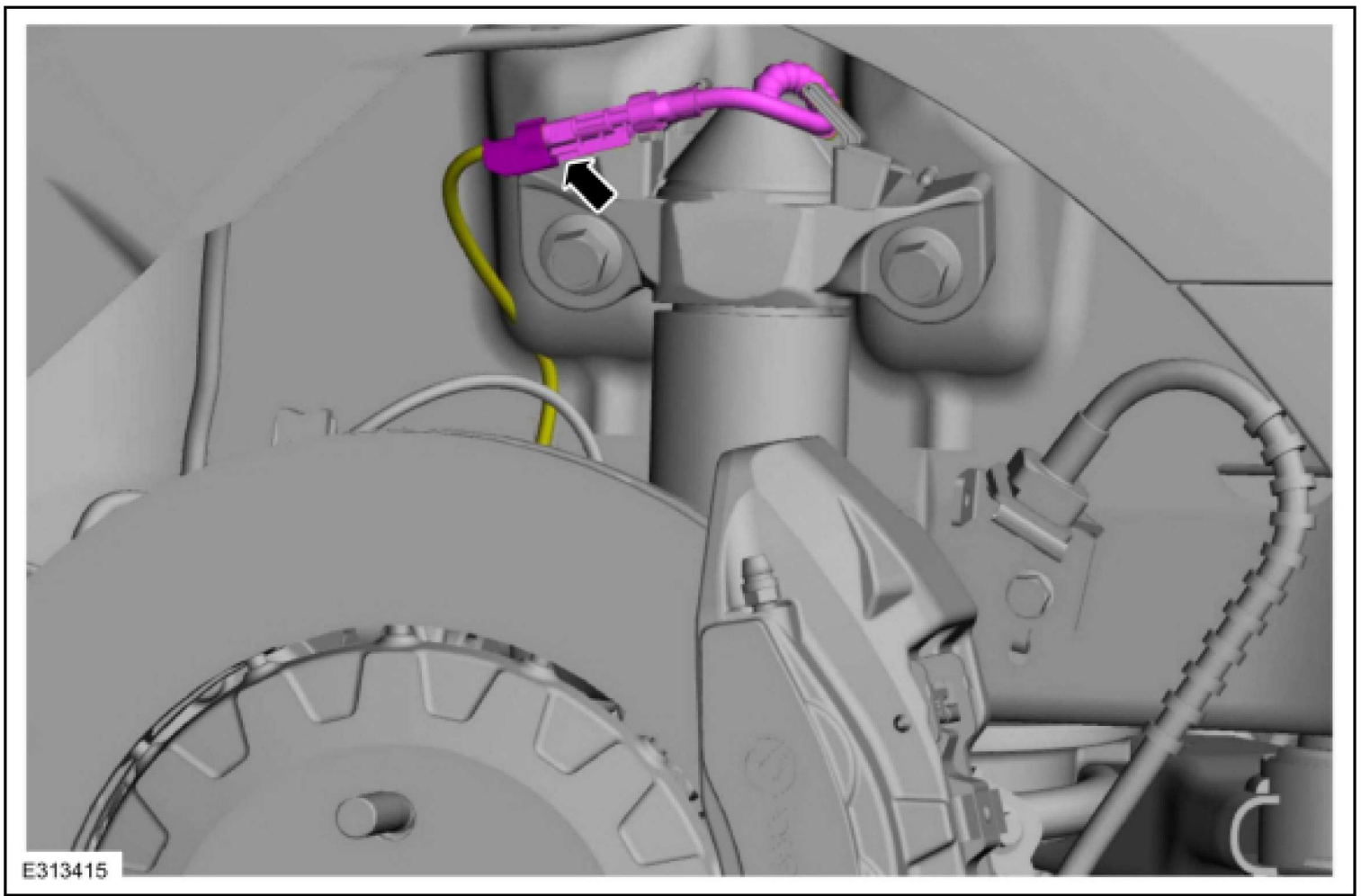

All vehicles

6. Install the rear shock absorber and install the new rear shock absorber lower bolts.
Torque : 41 lb.ft (55 Nm)

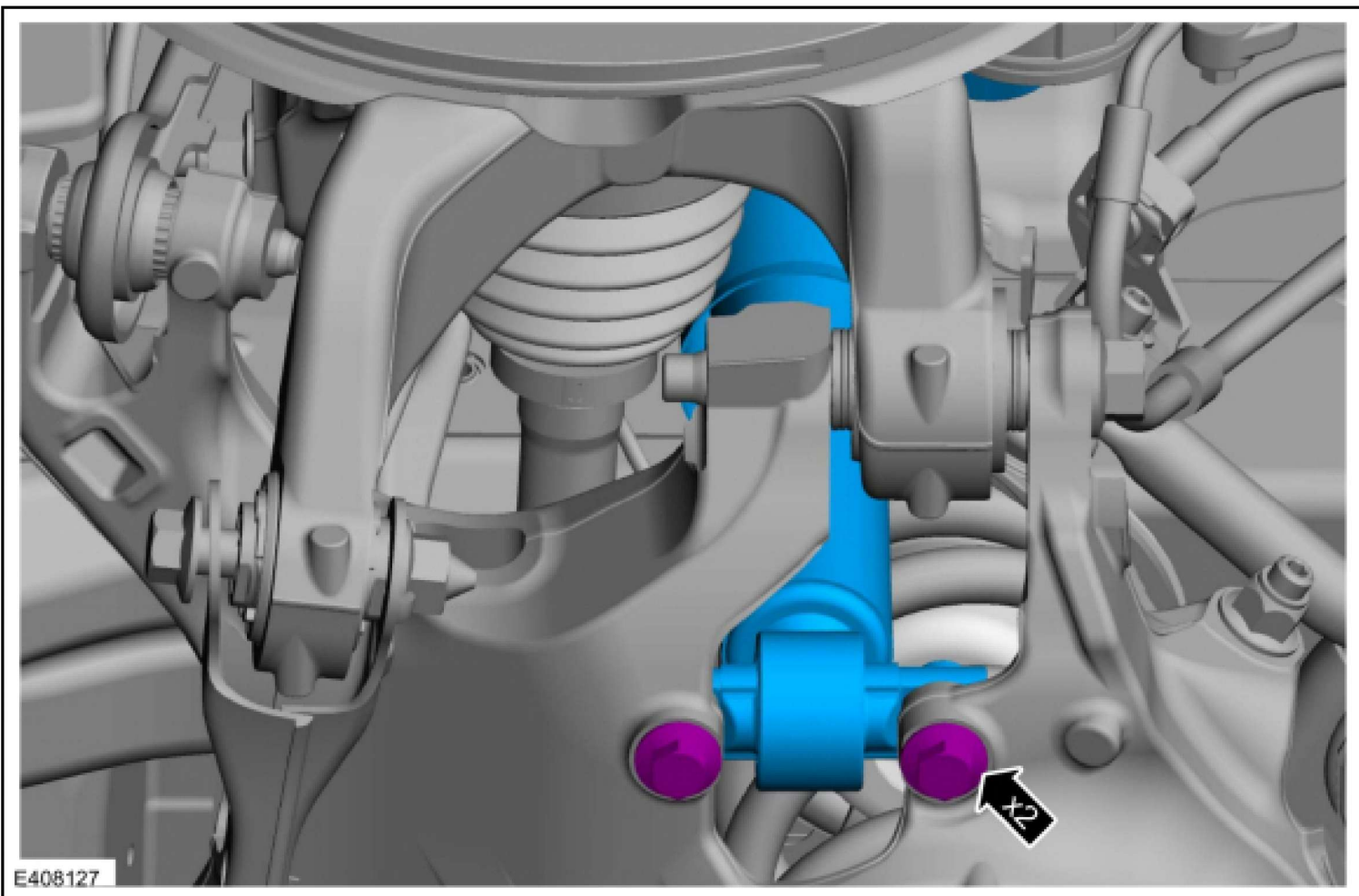

1. Align the rear shock absorber upper mount under the body alignment pins.
2. Install the new rear shock absorber upper bolts.
Torque : 76 lb.ft (103 Nm)

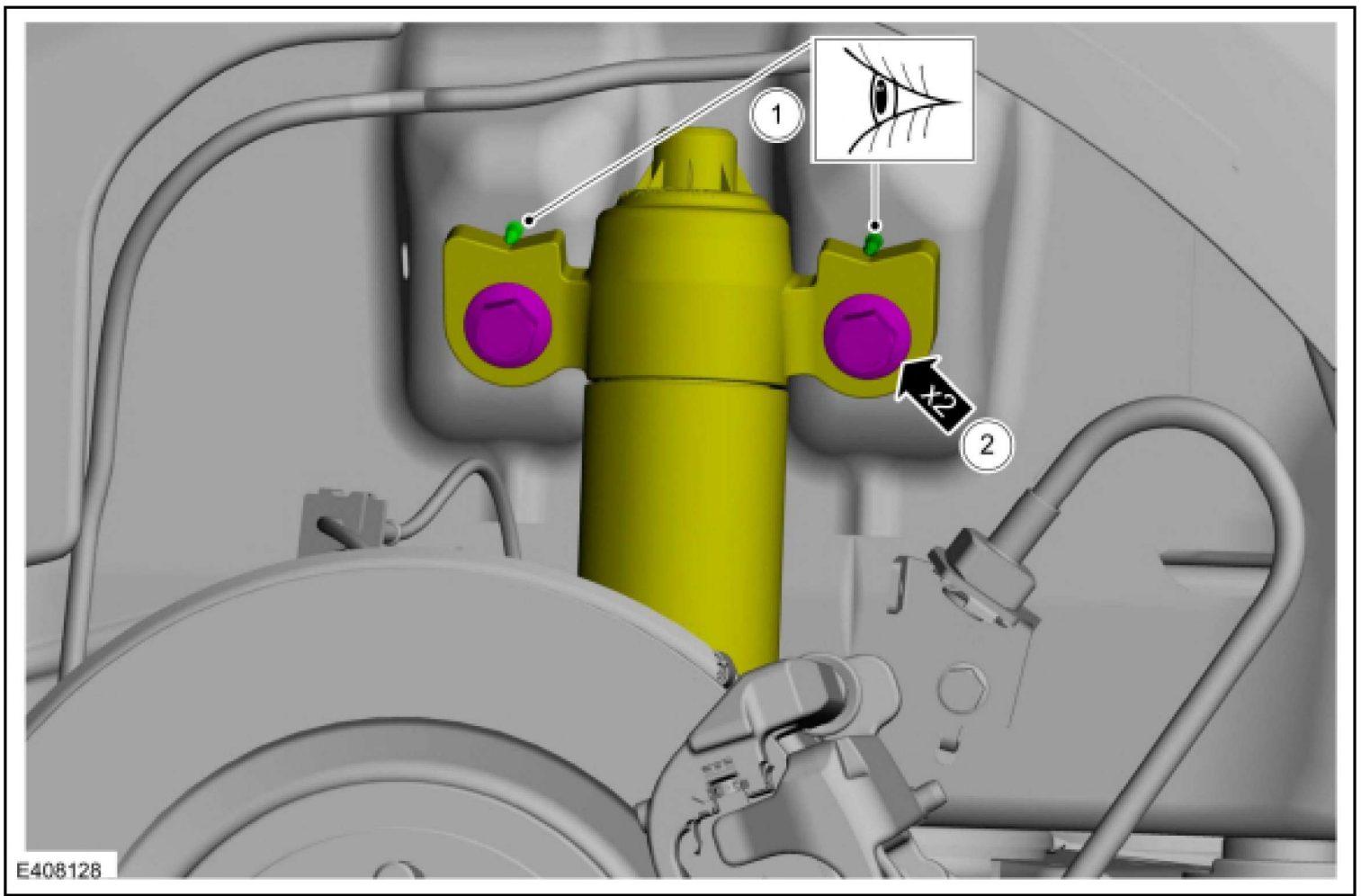

8. Install the wheel and tire.

Refer to: [Wheel and Tire](#) (204-04A Wheels and Tires, Removal and Installation) .

© Copyright 2025, Ford Motor Company.

Rear Stabilizer Bar



Removal

NOTICE: Suspension fasteners are critical parts that affect the performance of vital components and systems. Failure of these fasteners may result in major service expense. Use the same or equivalent parts if replacement is necessary. Do not use a replacement part of lesser quality or substitute design. Tighten fasteners as specified.

1. Remove the wheel and tire.
Refer to: [Wheel and Tire](#) (204-04A Wheels and Tires, Removal and Installation) .
2. **NOTICE:** Do not use power tools to remove or install the stabilizer bar link nuts. Damage to the stabilizer bar link ball joints and boots may occur.

NOTE: *The stabilizer bar links are designed with low friction ball joints that have a low breakaway torque.*

NOTE: *Use the hex-holding feature to prevent the ball stud from turning while removing the stabilizer bar link nut.*

On both sides.

Remove and discard the stabilizer bar link upper nut and position the stabilizer bar link aside.

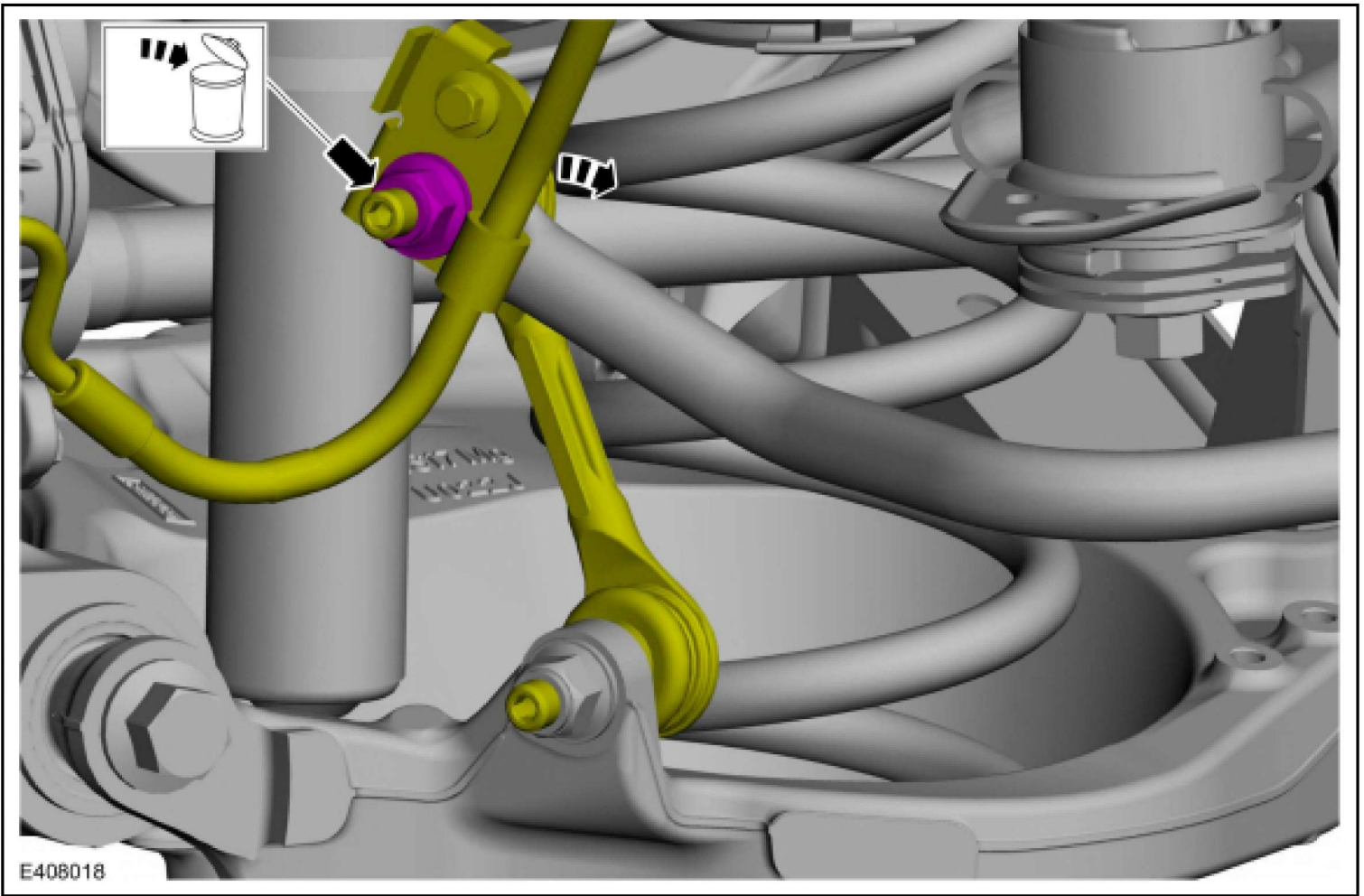

3. Remove and discard the stabilizer bar bracket bolts, remove the stabilizer bar brackets and remove the stabilizer bar.

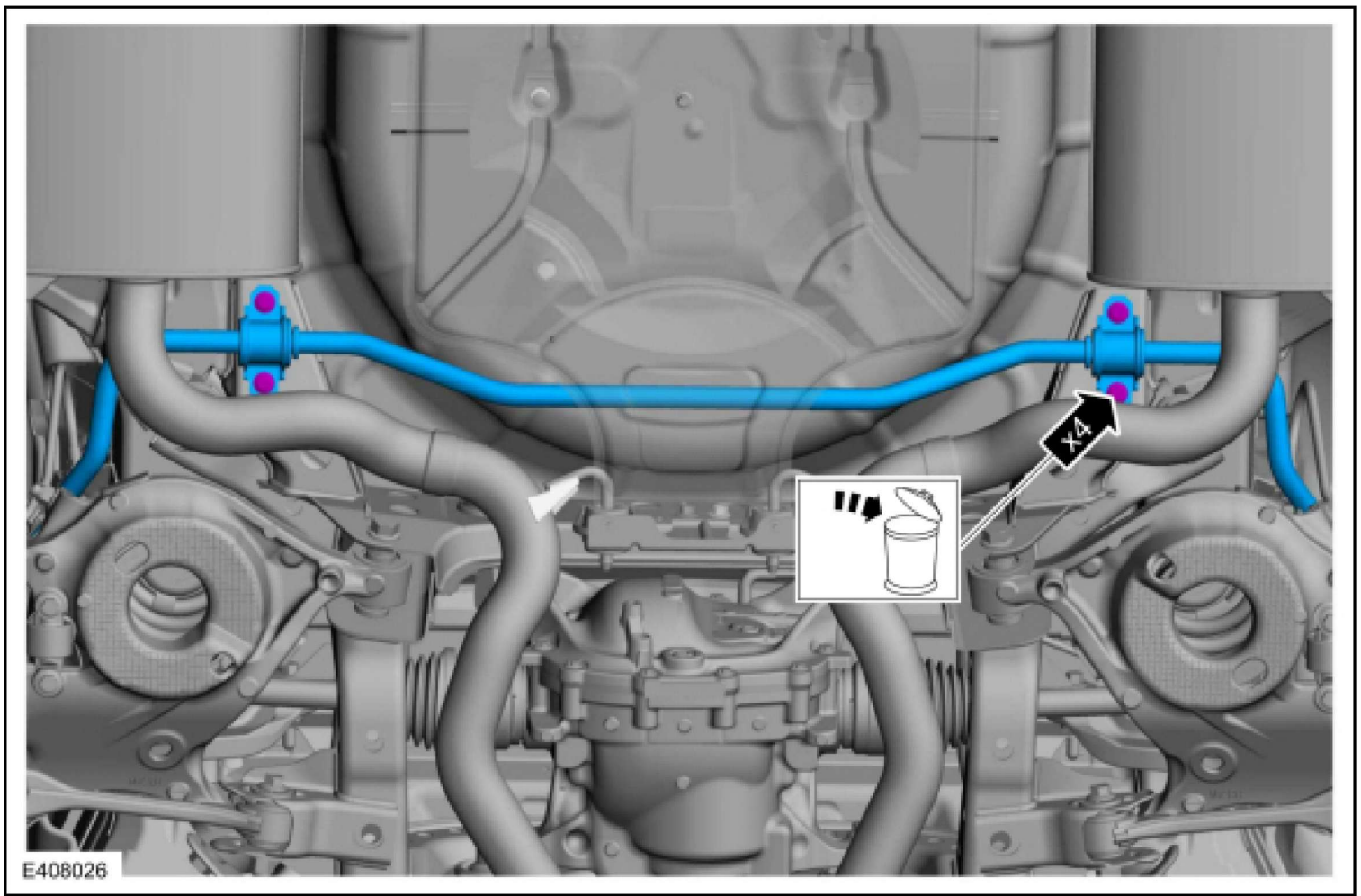

Installation

1. Position the stabilizer bar, the stabilizer bar brackets and install the new stabilizer bar bracket bolts.
Torque : 52 lb.ft (70 Nm)

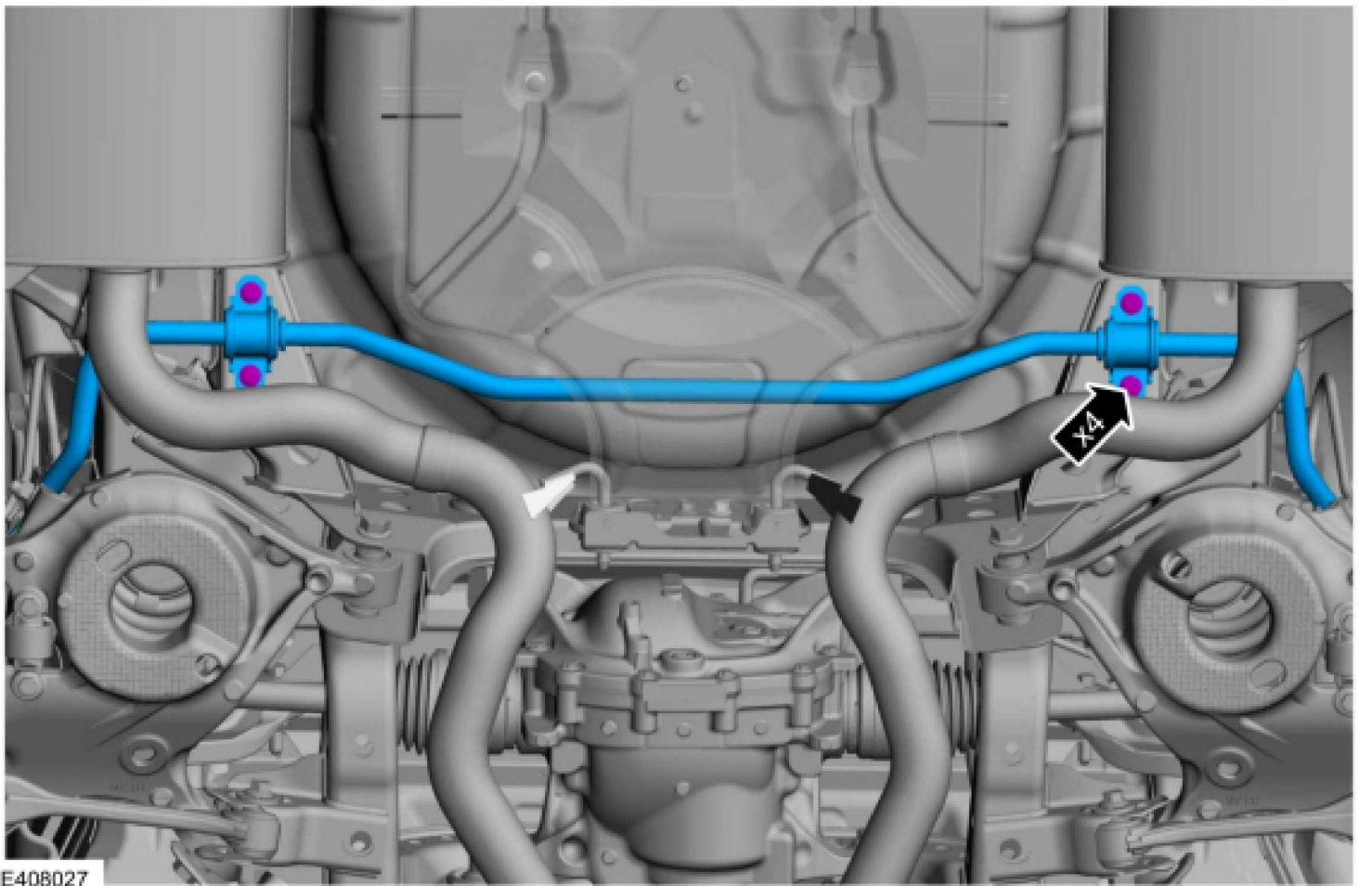

1. On both sides.
Position the stabilizer bar link.
2. **NOTICE: Do not use power tools to remove or install the stabilizer bar link nuts. Damage to the stabilizer bar link ball joints and boots may occur.**

NOTE: *The stabilizer bar links are designed with low friction ball joints that have a low breakaway torque.*

Use the hex-holding feature to prevent the ball stud from turning while installing the stabilizer bar link nut.

On both sides.
Install the new stabilizer bar link upper nut.
Torque : 85 lb.ft (115 Nm)

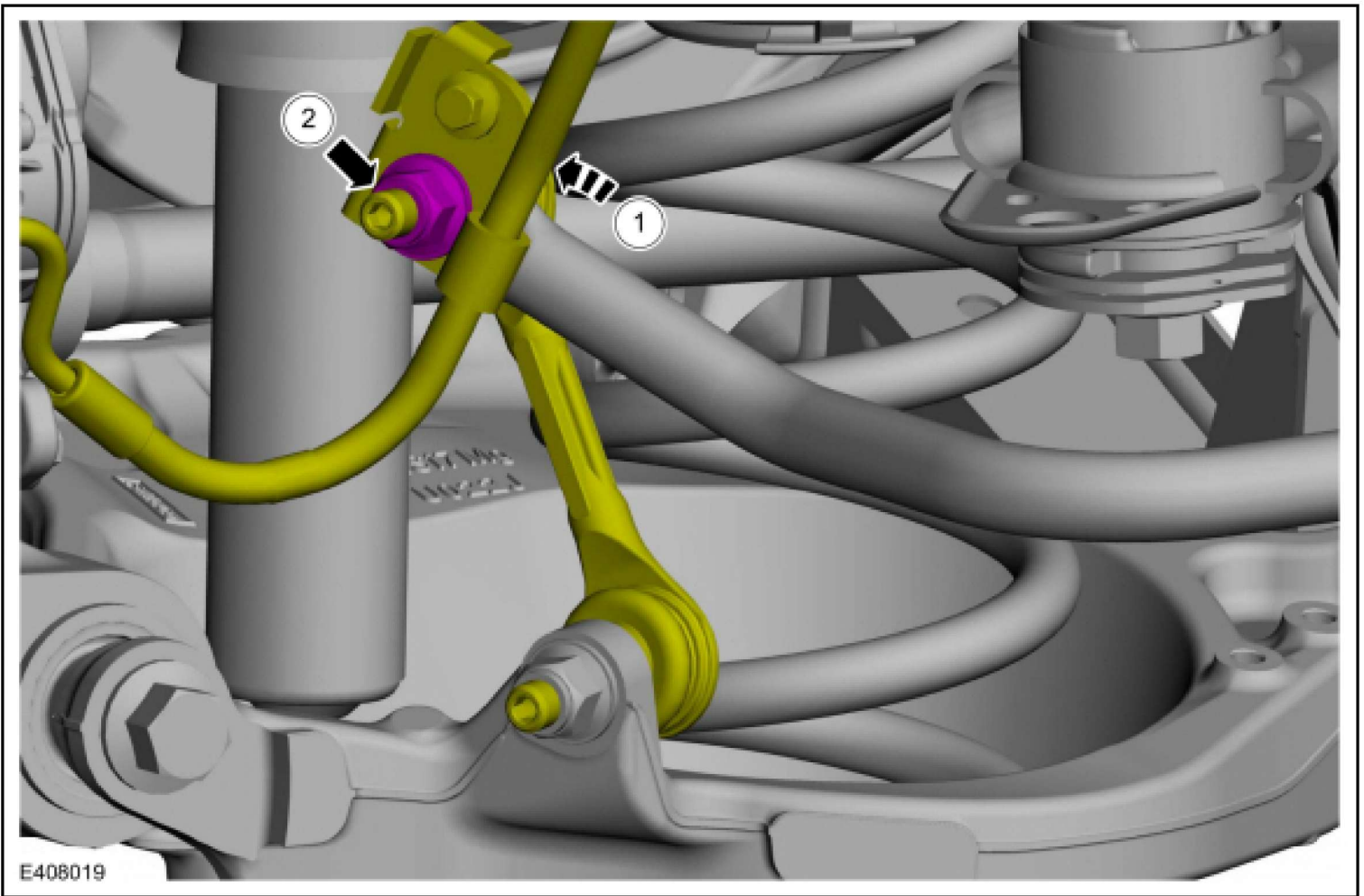

3. Install the wheel and tire.

Refer to: [Wheel and Tire](#) (204-04A Wheels and Tires, Removal and Installation) .

© Copyright 2025, Ford Motor Company.

Rear Stabilizer Bar Bushing



Removal

NOTICE: Suspension fasteners are critical parts that affect the performance of vital components and systems. Failure of these fasteners may result in major service expense. Use the same or equivalent parts if replacement is necessary. Do not use a replacement part of lesser quality or substitute design. Tighten fasteners as specified.

1. With the vehicle in NEUTRAL, position it on a hoist.
Refer to: [Jacking and Lifting - Overview](#) (100-02 Jacking and Lifting, Description and Operation) .
2. On both sides.
 1. Remove and discard the rear stabilizer bar bushing bracket bolts.
 2. Remove the rear stabilizer bar bushing bracket.

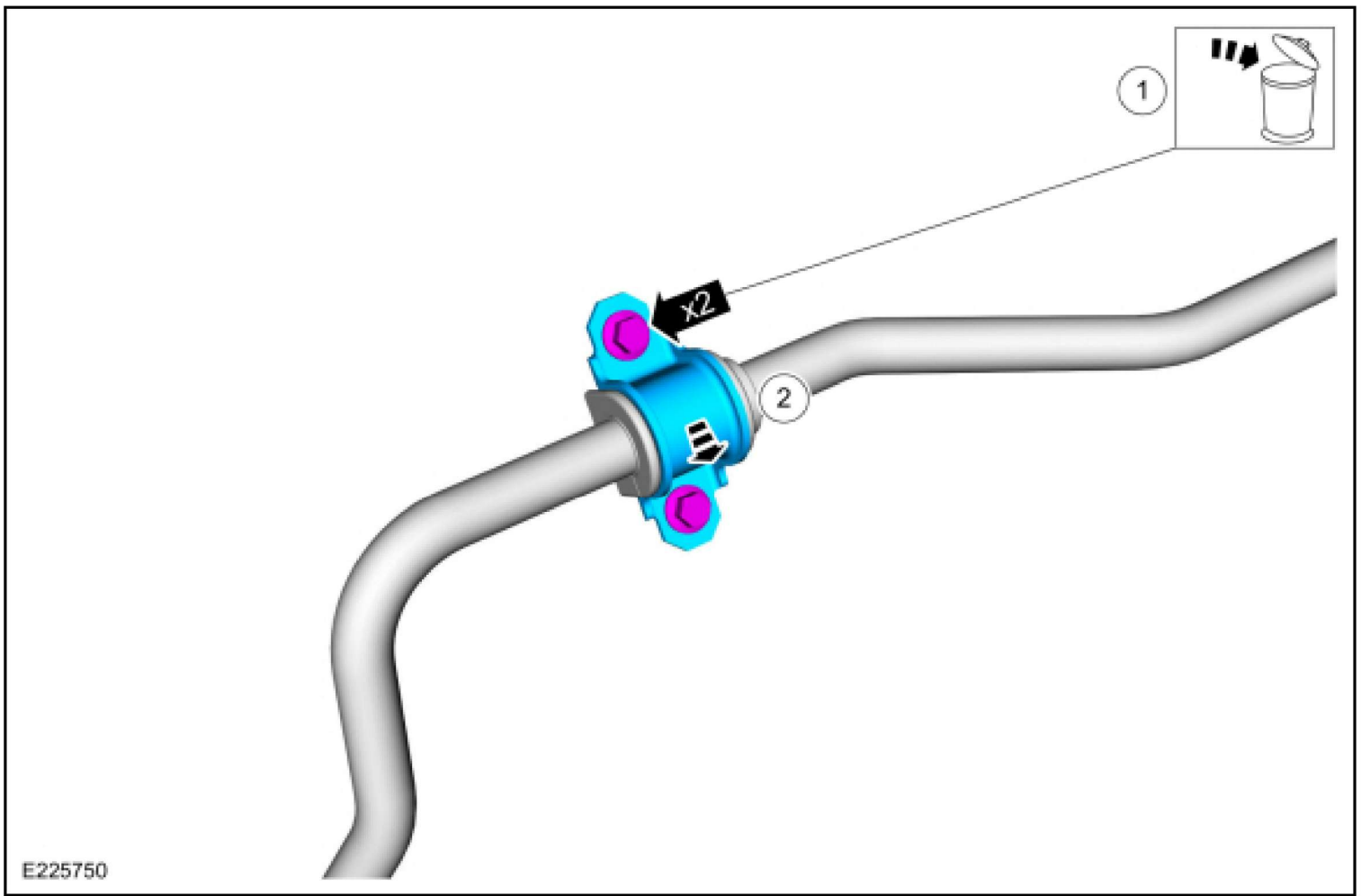

3. On both sides.
Remove the rear stabilizer bar bushing.

E225751

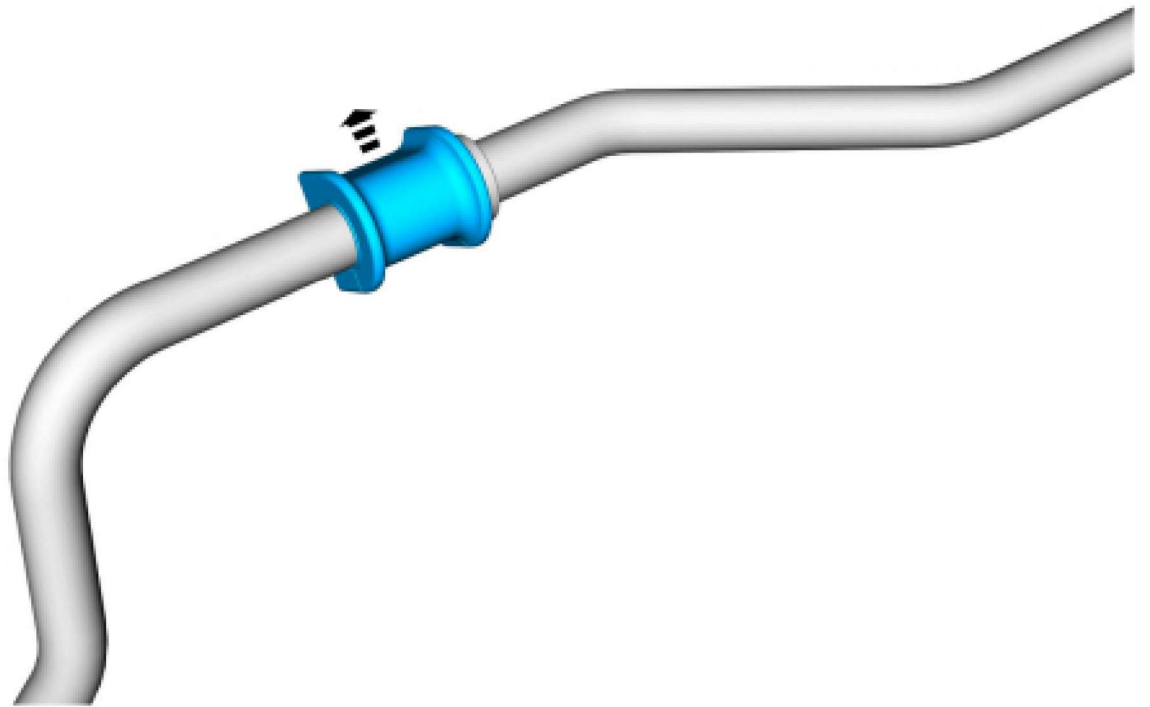

Installation

1. **NOTICE: Do not use any lubrication on the stabilizer bar or the bushings or damage to the bushings may occur.**

NOTE: *Stabilizer bar bushings must be installed with slits facing the front of the vehicle.*

On both sides.

Install the rear stabilizer bar bushing.

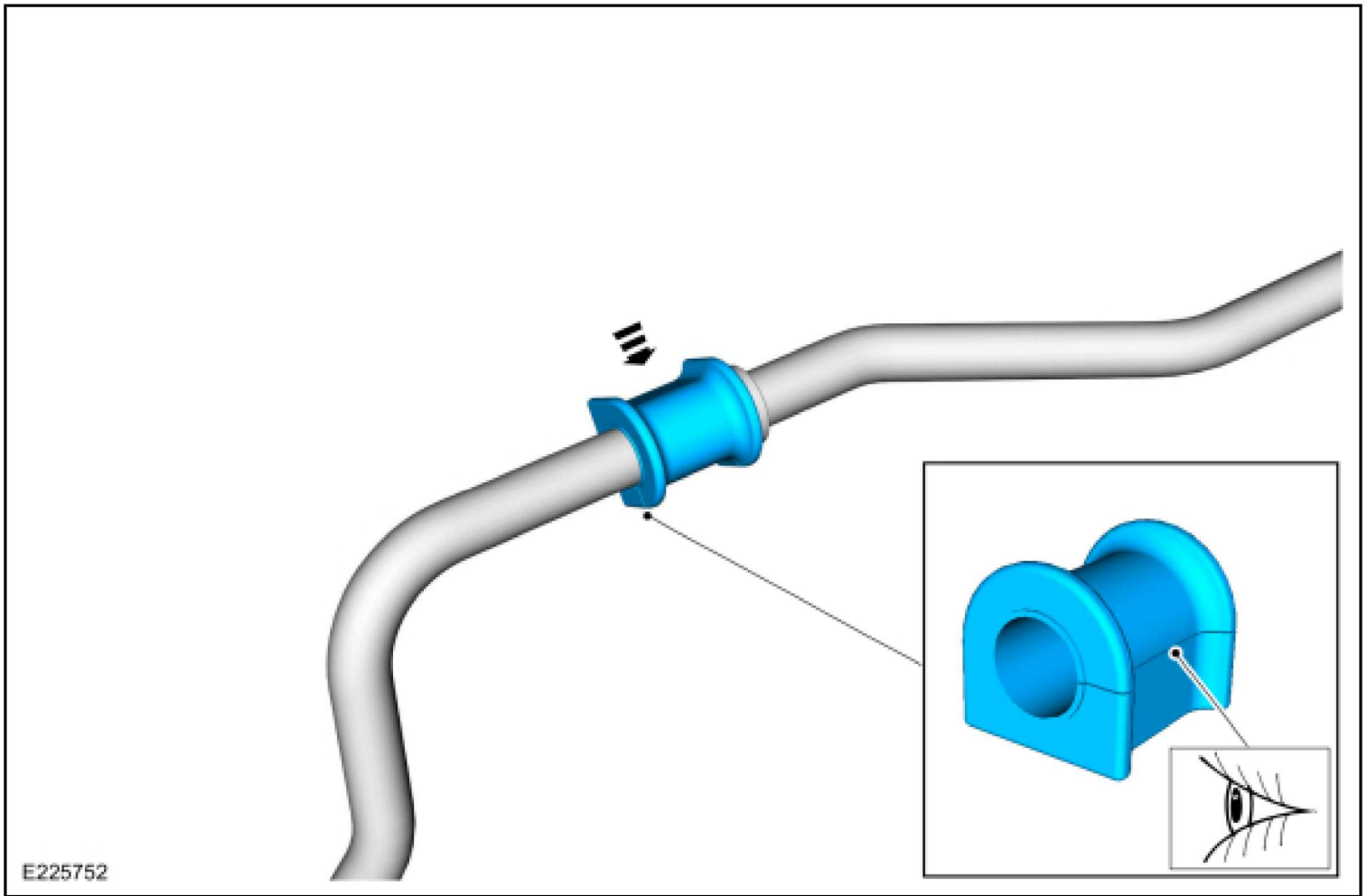

2. **NOTE:** *Water may be applied to the bracket to aid in installation.*

On both sides.

1. Install the rear stabilizer bar bushing bracket.
2. Install the new rear stabilizer bar bushing bracket bolts.
Torque : 52 lb.ft (70 Nm)

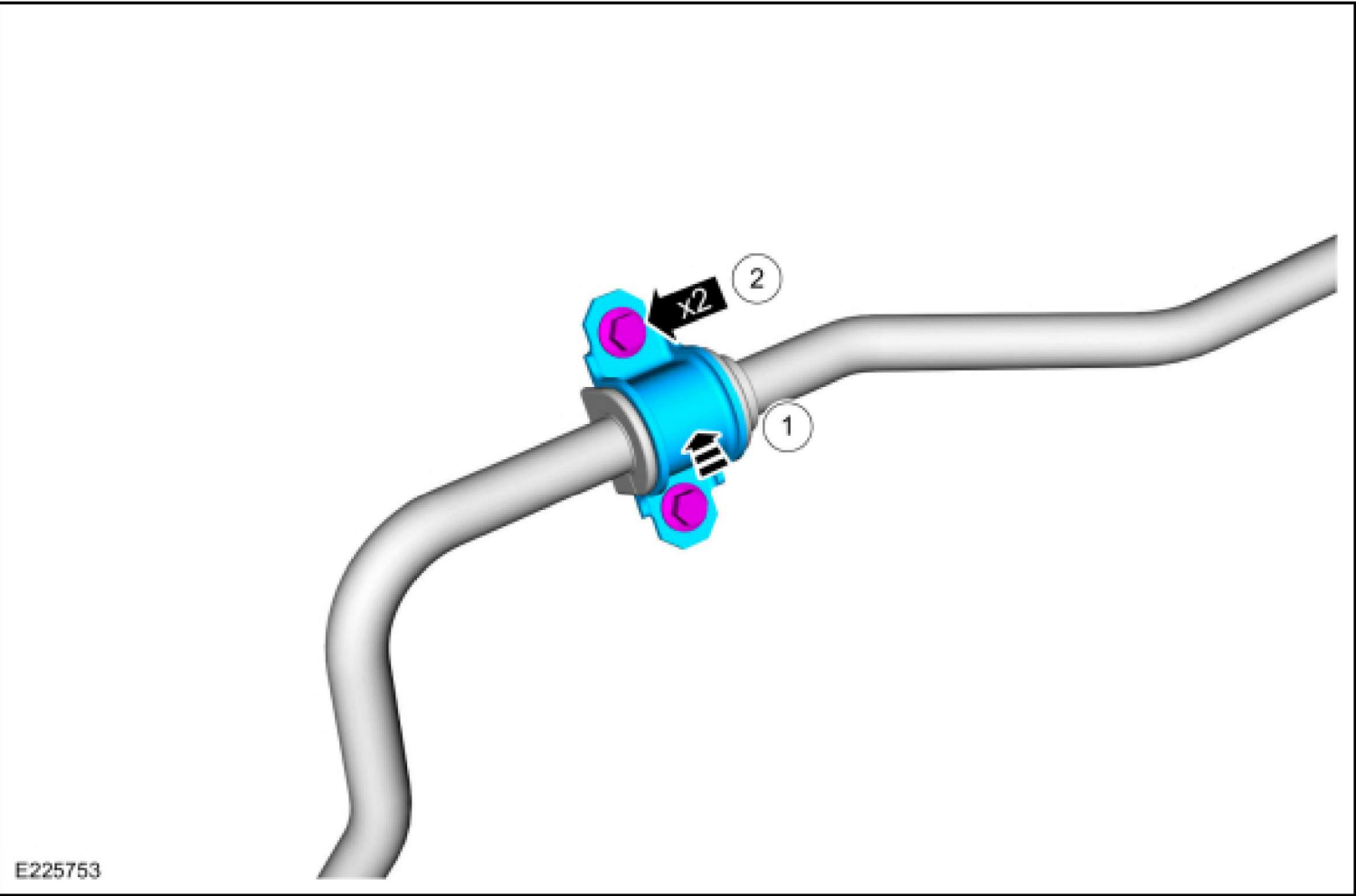

E225753

© Copyright 2025, Ford Motor Company.

Rear Stabilizer Bar Link



Removal

NOTICE: Suspension fasteners are critical parts that affect the performance of vital components and systems. Failure of these fasteners may result in major service expense. Use the same or equivalent parts if replacement is necessary. Do not use a replacement part of lesser quality or substitute design. Tighten fasteners as specified.

NOTE: Removal steps in this procedure may contain installation details.

1. **NOTICE:** Do not use power tools to remove or install the stabilizer bar link nuts. Damage to the stabilizer bar link ball joints and boots may occur.

NOTE: The stabilizer bar links are designed with low friction ball joints that have a low breakaway torque.

NOTE: Use the hex-holding feature to prevent the ball stud from turning while removing the stabilizer bar link nut.

Remove and discard the rear stabilizer bar link nuts and remove the rear stabilizer bar link.
Torque : 85 lb.ft (115 Nm)

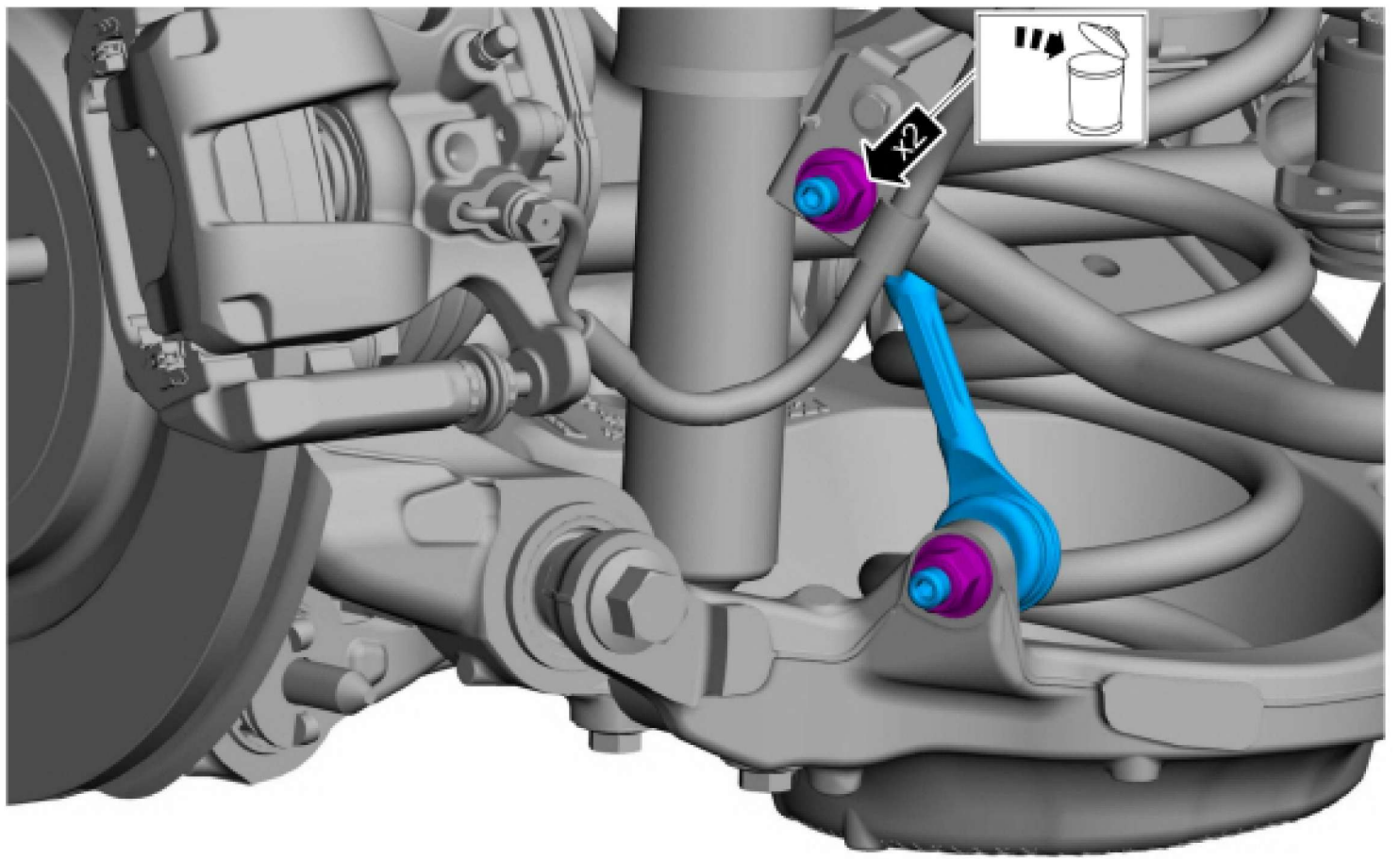

E408017



Installation

1. To install, reverse the removal procedure.

© Copyright 2025, Ford Motor Company.

Spring



Removal

1. Remove the lower arm.
Refer to: [Lower Arm](#) (204-02 Rear Suspension, Removal and Installation) .
Refer to: [Lower Arm - Dark Horse/GT](#) (204-02 Rear Suspension, Removal and Installation) .
2. Remove the spring.

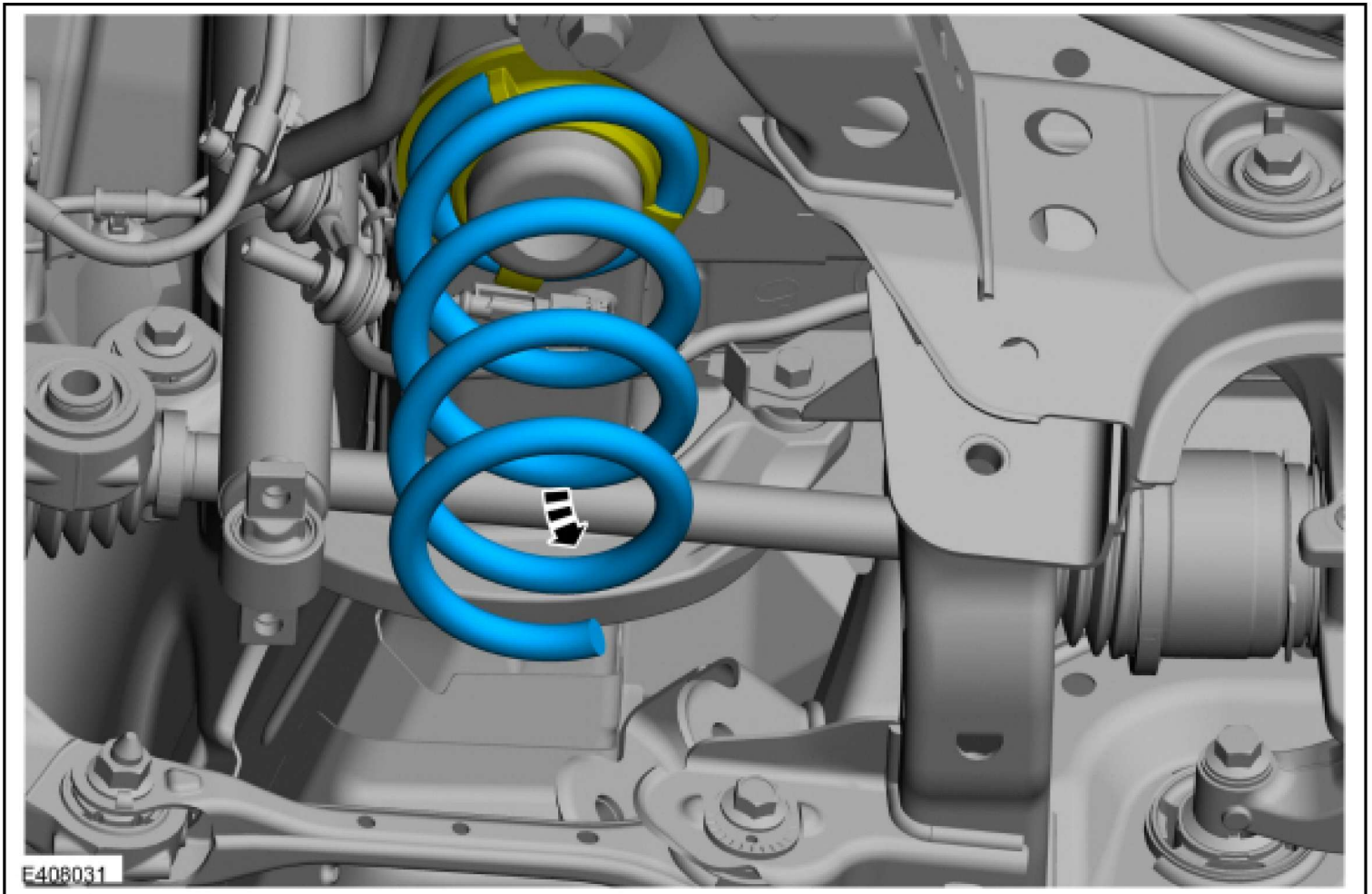

3. Inspect the upper spring seat for damage. Replace as necessary.

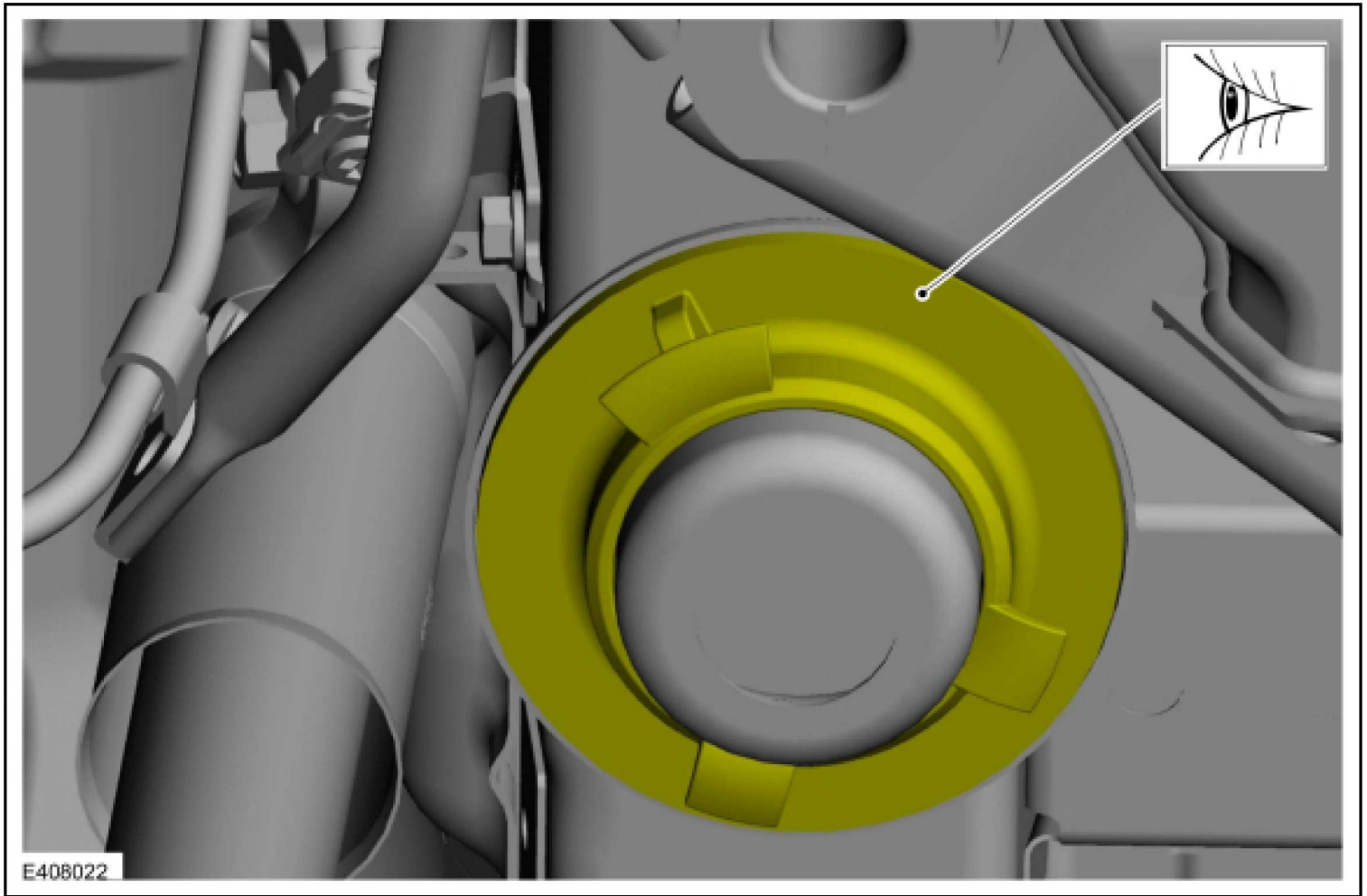

Installation

1. Install the spring.

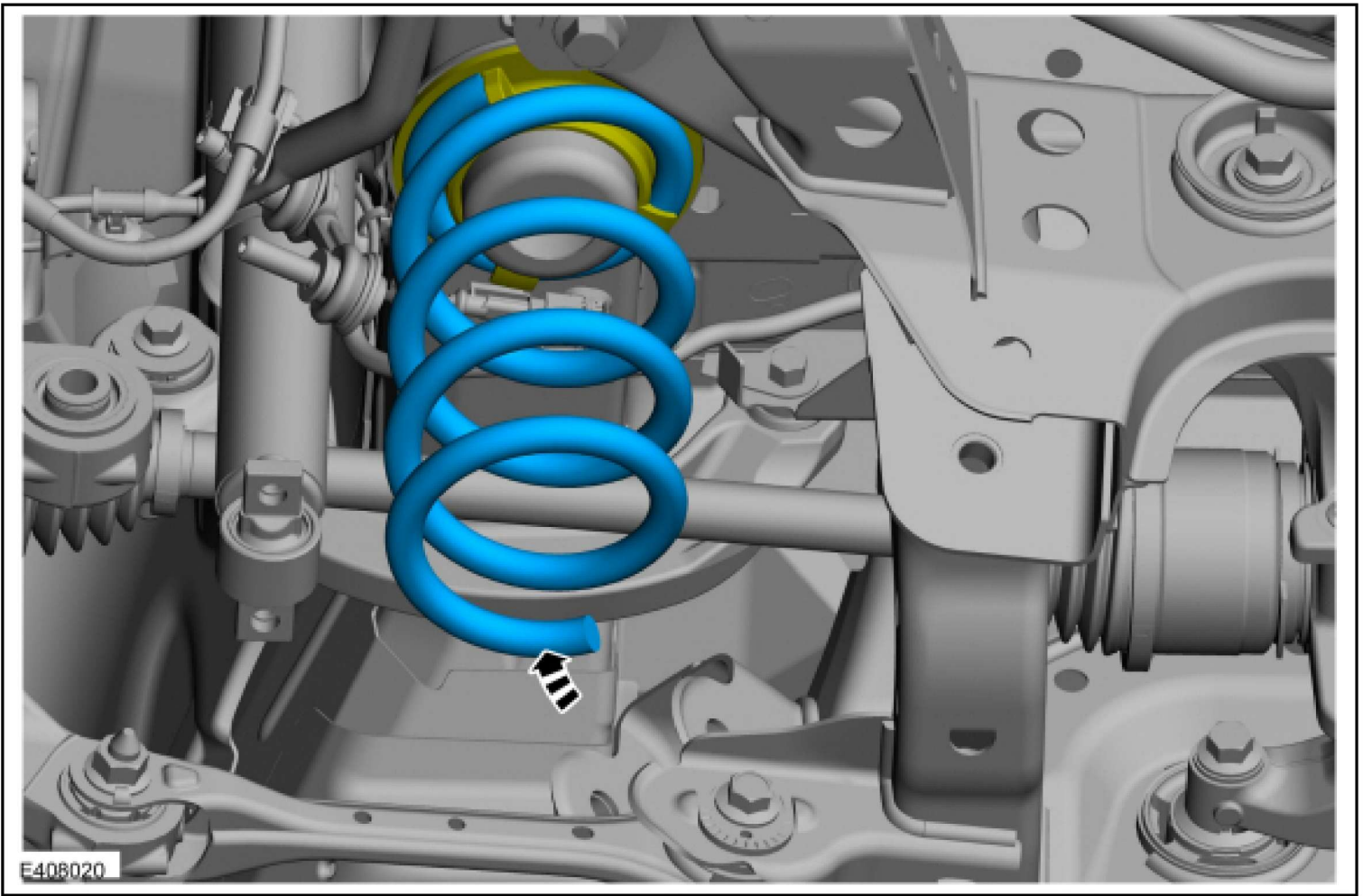

2. Make sure that the spring is correctly located in the upper spring seat.

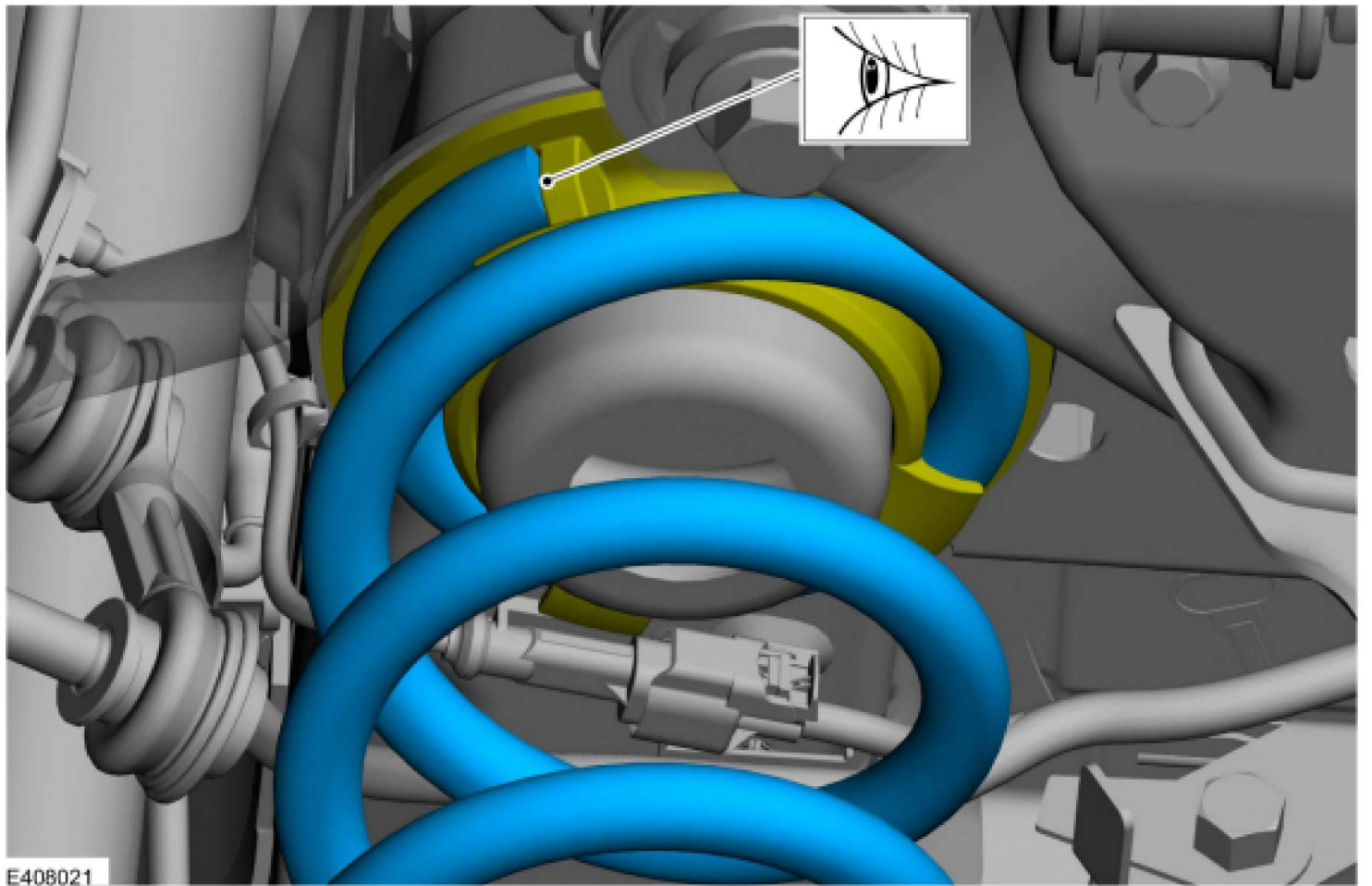

3. Install the lower arm.

Refer to: [Lower Arm](#) (204-02 Rear Suspension, Removal and Installation) .

Refer to: [Lower Arm - Dark Horse/GT](#) (204-02 Rear Suspension, Removal and Installation) .

© Copyright 2025, Ford Motor Company.

Toe Link



Removal

NOTICE: Suspension fasteners are critical parts that affect the performance of vital components and systems. Failure of these fasteners may result in major service expense. Use the same or equivalent parts if replacement is necessary. Do not use a replacement part of lesser quality or substitute design. Tighten fasteners as specified.

1. Remove the wheel and tire.
Refer to: [Wheel and Tire](#) (204-04A Wheels and Tires, Removal and Installation) .
2. Support the suspension at curb height.

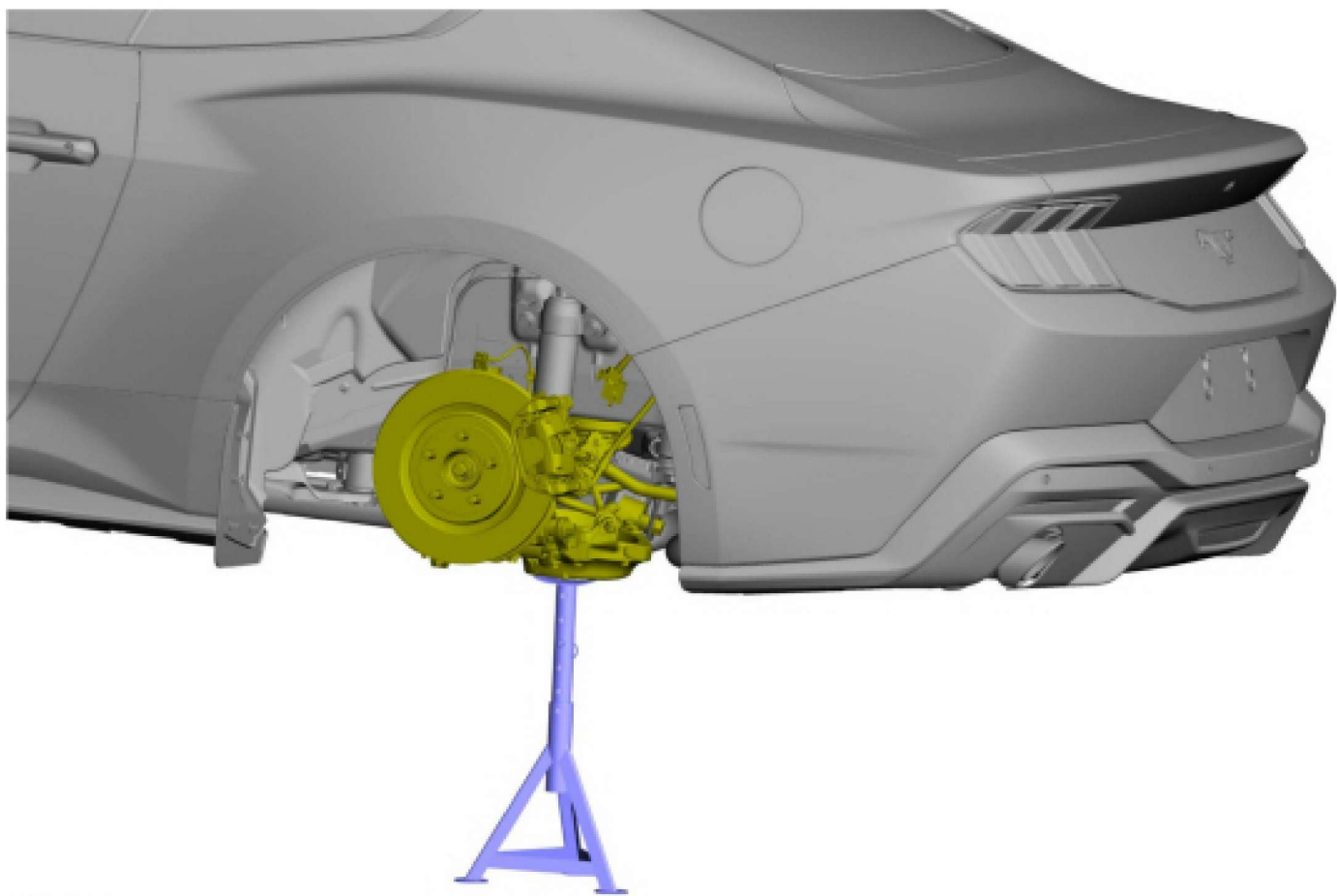

E408028

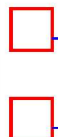

1. Index mark both the inner and outer cam wheels for use during assembly.
2. Remove and discard the toe link-to-knuckle bolt, the toe link-to-frame bolt, washer and nut and remove the toe link.

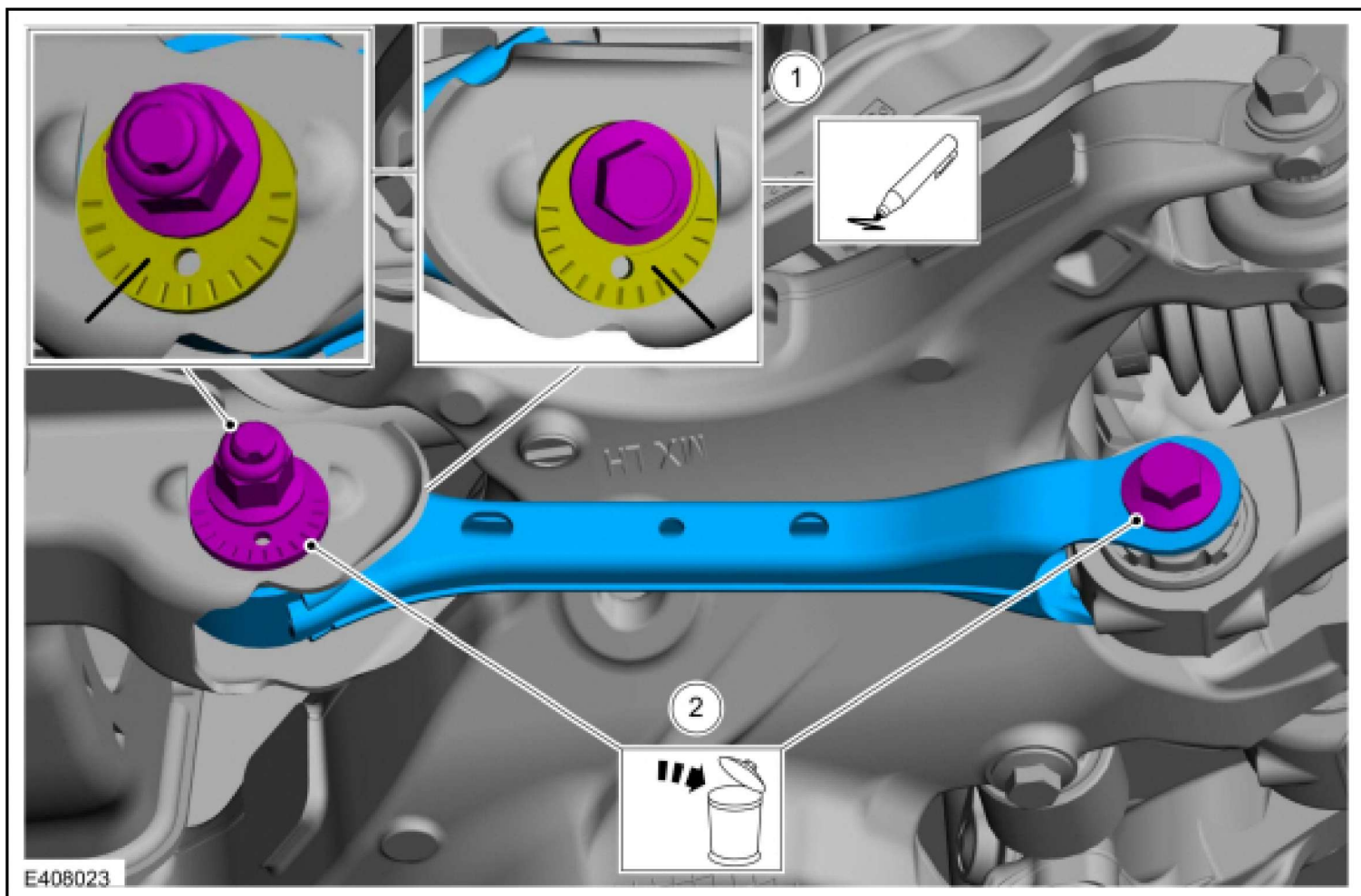

Installation

NOTICE: Tighten the suspension bushing fasteners with the suspension loaded or with the weight of the vehicle resting on the wheels and tires, otherwise incorrect clamp load and bushing damage may occur.

1. **NOTE:** *Align reference marks made during removal.*

Position the toe link.

1. Install the new toe link-to-frame bolt, washer and nut.

Torque :

Stage 1: 18 lb.ft (25 Nm)

Stage 2: 148 lb.ft (200 Nm)

2. Install the new toe link-to-knuckle bolt.

Torque : 129 lb.ft (175 Nm)

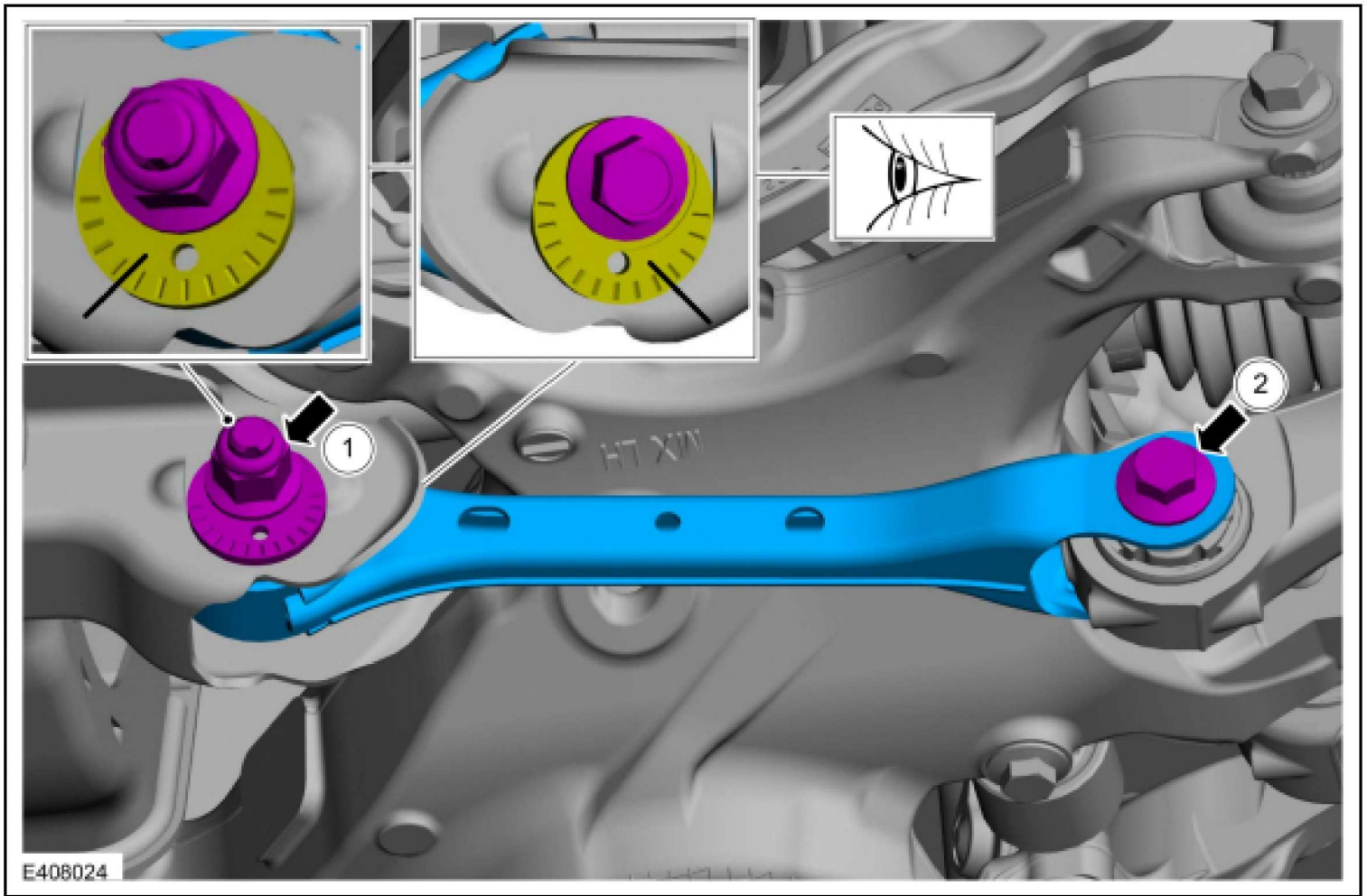

2. Install the wheel and tire.

Refer to: [Wheel and Tire](#) (204-04A Wheels and Tires, Removal and Installation) .

3. Recheck rear toe and adjust as necessary.

Refer to: [Rear Toe Adjustment](#) (204-00 Suspension System - General Information, General Procedures) .

© Copyright 2025, Ford Motor Company.

Upper Arm



Removal

NOTICE: Suspension fasteners are critical parts that affect the performance of vital components and systems. Failure of these fasteners may result in major service expense. Use the same or equivalent parts if replacement is necessary. Do not use a replacement part of lesser quality or substitute design. Tighten fasteners as specified.

NOTE: *Removal steps in this procedure may contain installation details.*

1. Remove the wheel and tire.
Refer to: [Wheel and Tire](#) (204-04A Wheels and Tires, Removal and Installation) .
2. Support the suspension at curb height.

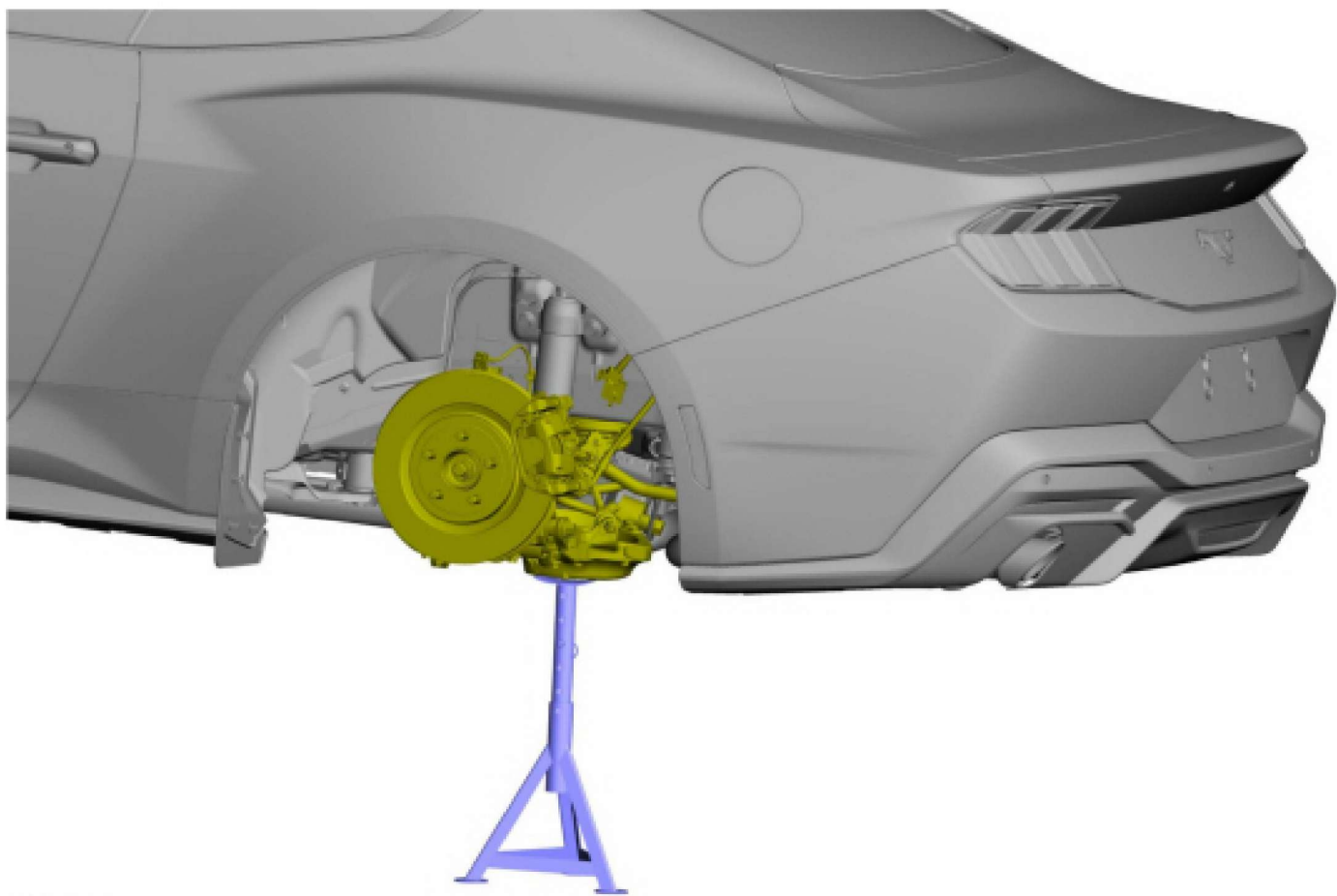

E408028

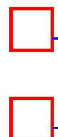

3. **NOTICE:** Tighten the suspension bushing fasteners with the suspension loaded or with the weight of the vehicle resting on the wheels and tires, otherwise incorrect clamp load and bushing damage may occur.

1. Remove and discard the upper arm-to-wheel knuckle bolt and nut.
Torque : 76 lb.ft (103 Nm)
2. Remove and discard the upper arm-to-frame flag-bolt and nut and remove the upper arm.
Torque : 85 lb.ft (115 Nm)

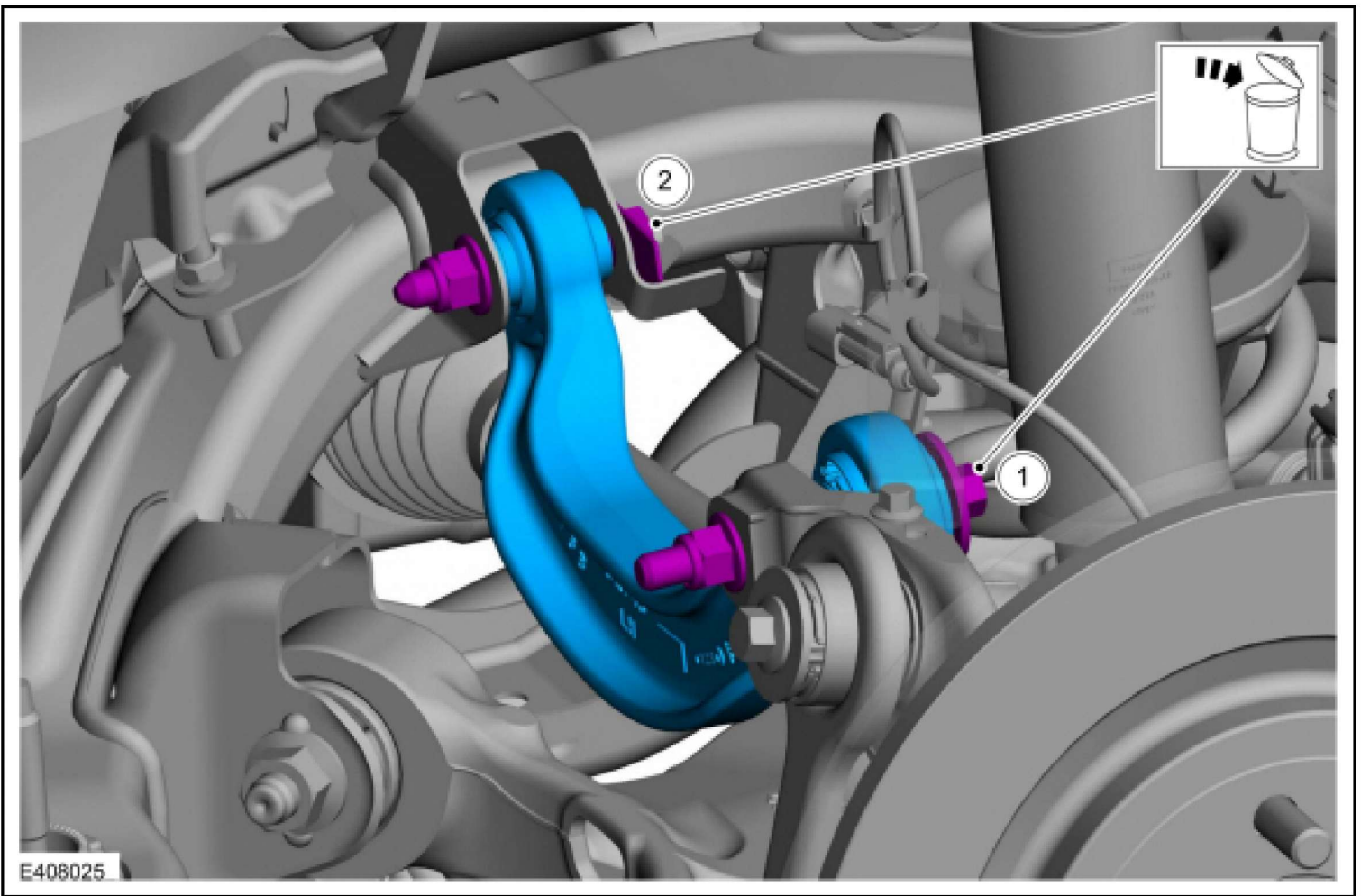

Installation

1. To install, reverse the removal procedure.
2. Check and if necessary adjust rear camber.
Refer to: [Rear Camber Adjustment](#) (204-00 Suspension System - General Information, General Procedures) .

© Copyright 2025, Ford Motor Company.

Wheel Bearing and Wheel Hub



Special Tool(s) / General Equipment

	205-D070 (D93P-1175-B) Remover, Front Wheel Hub
--	---

Removal

NOTICE: Suspension fasteners are critical parts that affect the performance of vital components and systems. Failure of these fasteners may result in major service expense. Use the same or equivalent parts if replacement is necessary. Do not use a replacement part of lesser quality or substitute design. Tighten fasteners as specified.

1. Remove the wheel and tire.
Refer to: [Wheel and Tire](#) (204-04A Wheels and Tires, Removal and Installation) .
2. Remove and discard the wheel hub nut.

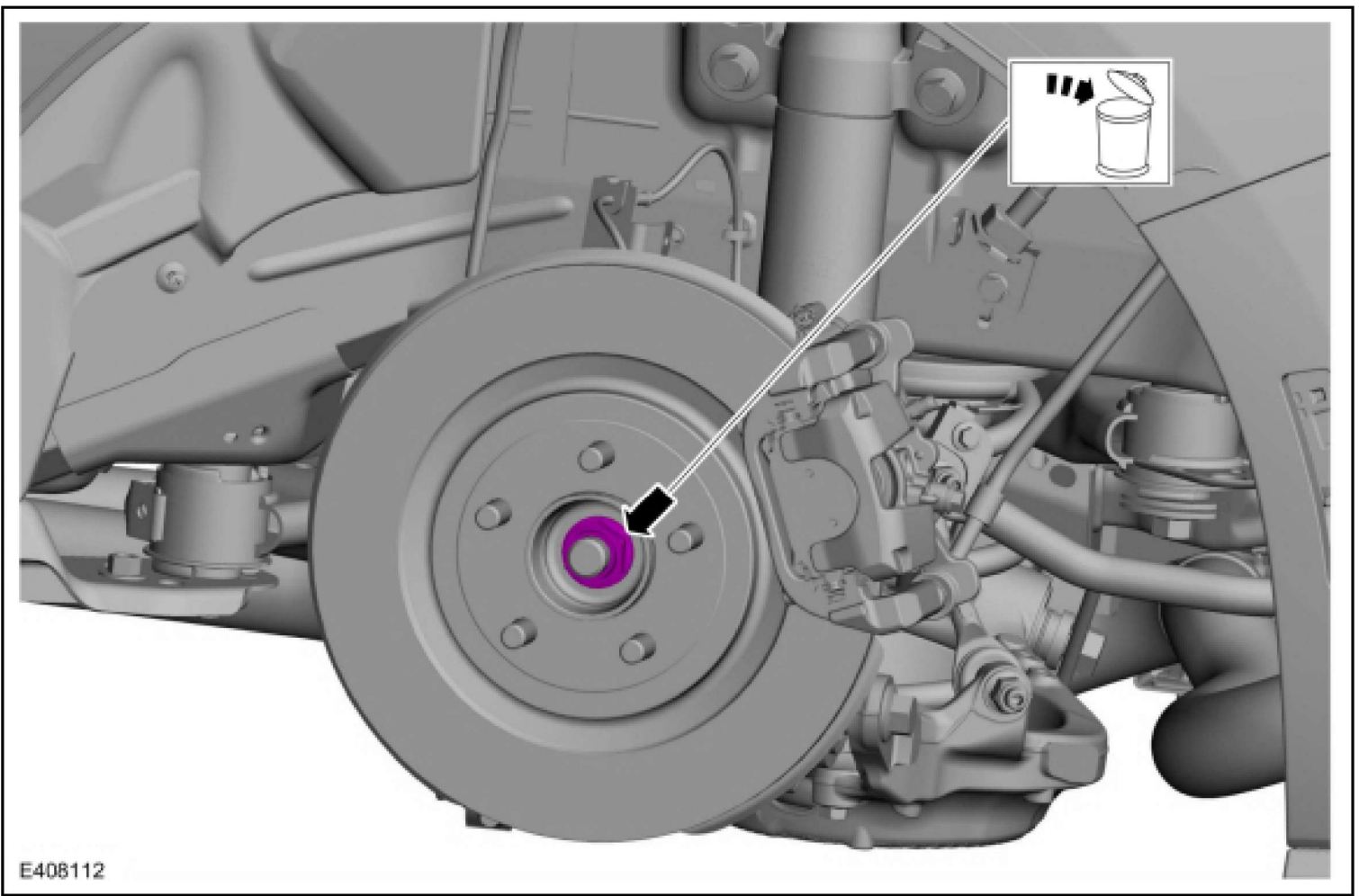

3. Remove the brake disc shield.

Refer to: [Brake Disc Shield](#) (206-04 Rear Disc Brake, Removal and Installation) .

4. **NOTE:** *Push the halfshaft into the wheel hub to gain access for the removal of the wheel bearing and wheel hub bolts.*

Using the special tool, press the halfshaft from the front wheel bearing and hub.

Use Special Service Tool: 205-D070 (D93P-1175-B) Remover, Front Wheel Hub .

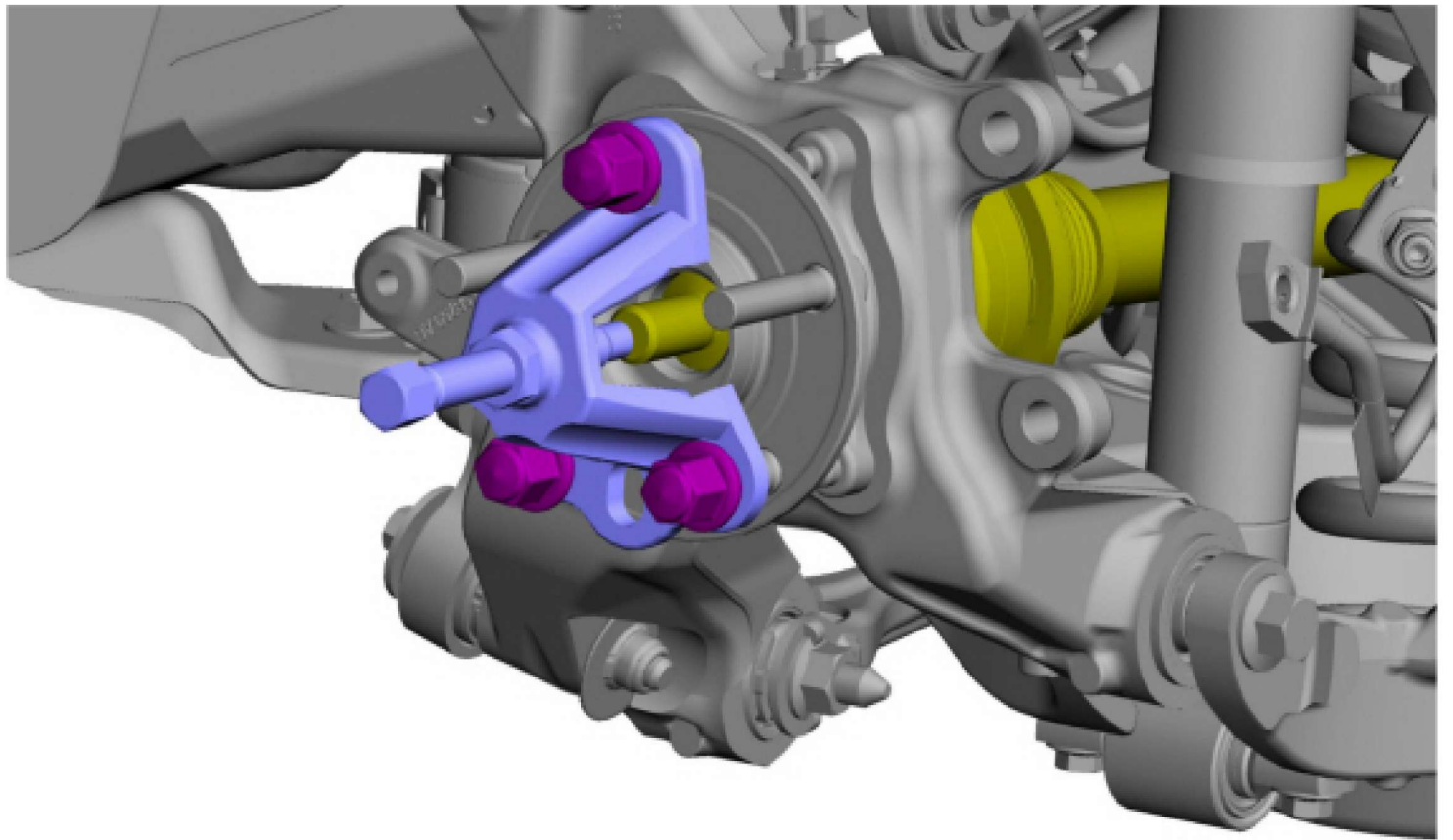

E321458



5. Remove the bolt and position aside the front wheel speed sensor.

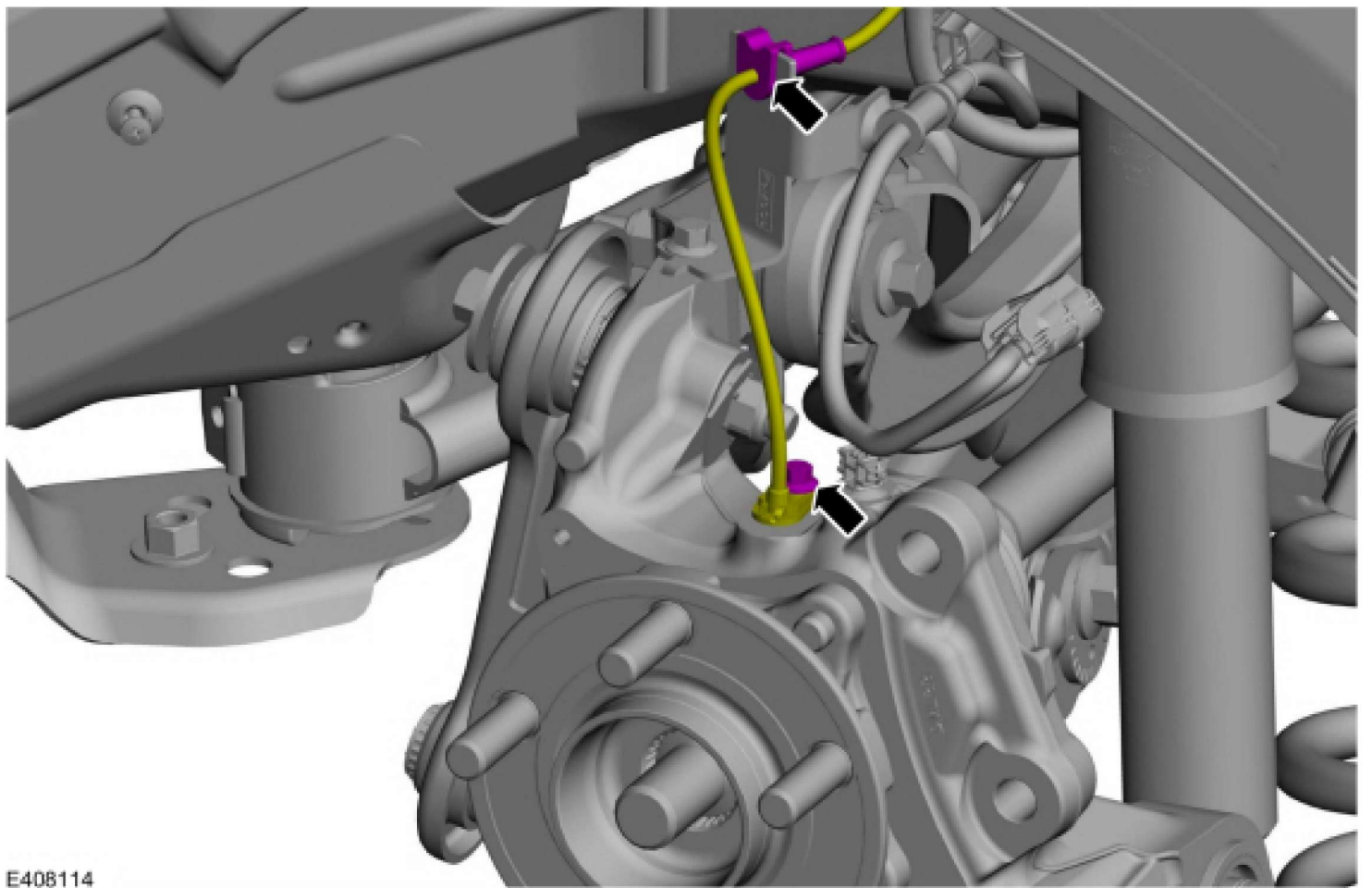

6. Remove and discard the wheel bearing and wheel hub bolts and remove the wheel bearing and wheel hub.

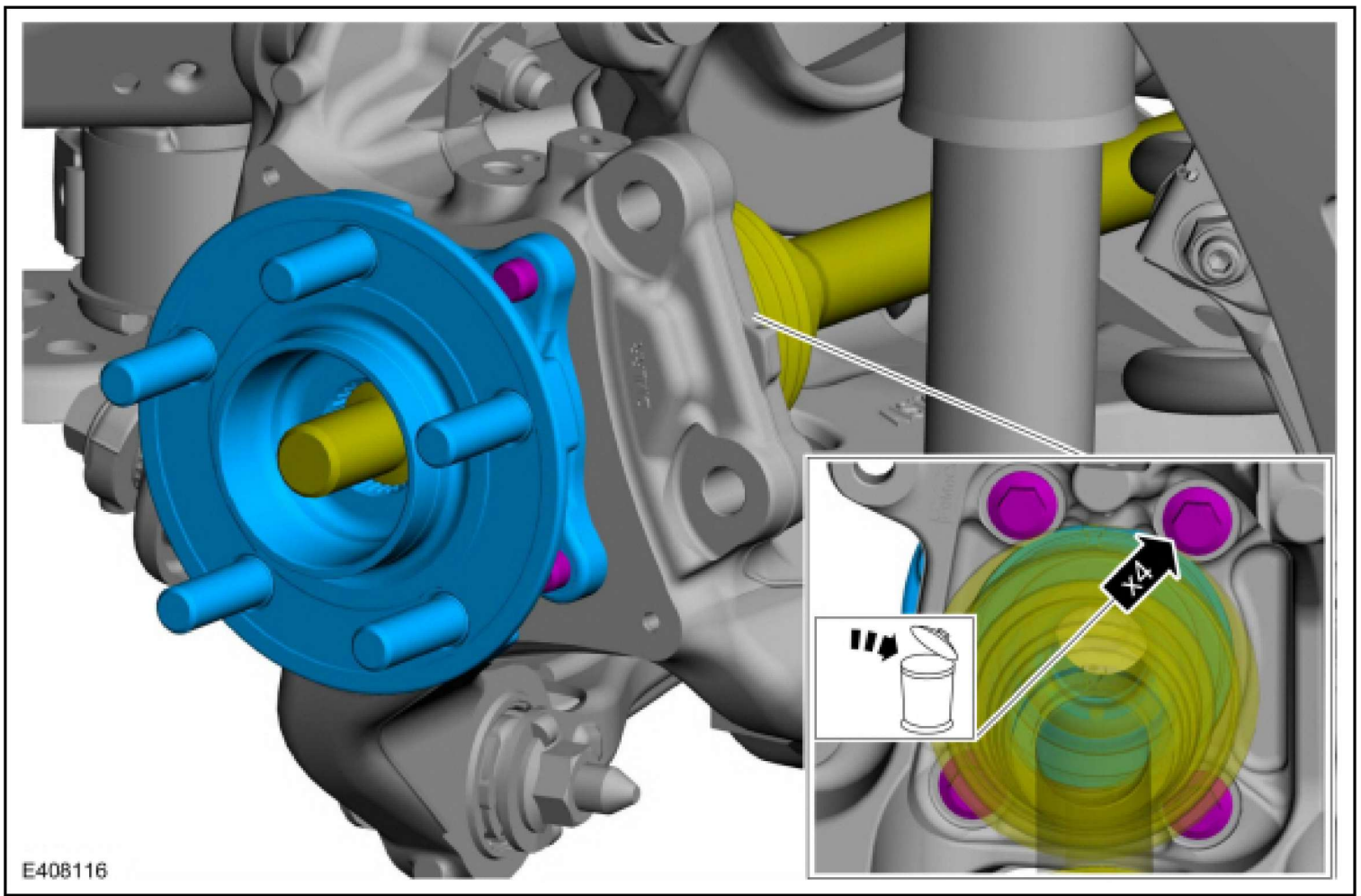

E408116



Installation

NOTICE: The wheel knuckle bore must be clean enough to allow the wheel bearing and wheel hub to seat completely by hand. Do not press or draw the wheel hub and bearing into place or damage to the bearing may occur.

NOTICE: Make sure the wheel hub-to-wheel knuckle mating surfaces are clean and free of any adhesive. Failure to clean the adhesive from both surfaces may cause bearing damage.

1. Clean and inspect the wheel hub-to-wheel knuckle mating surfaces.

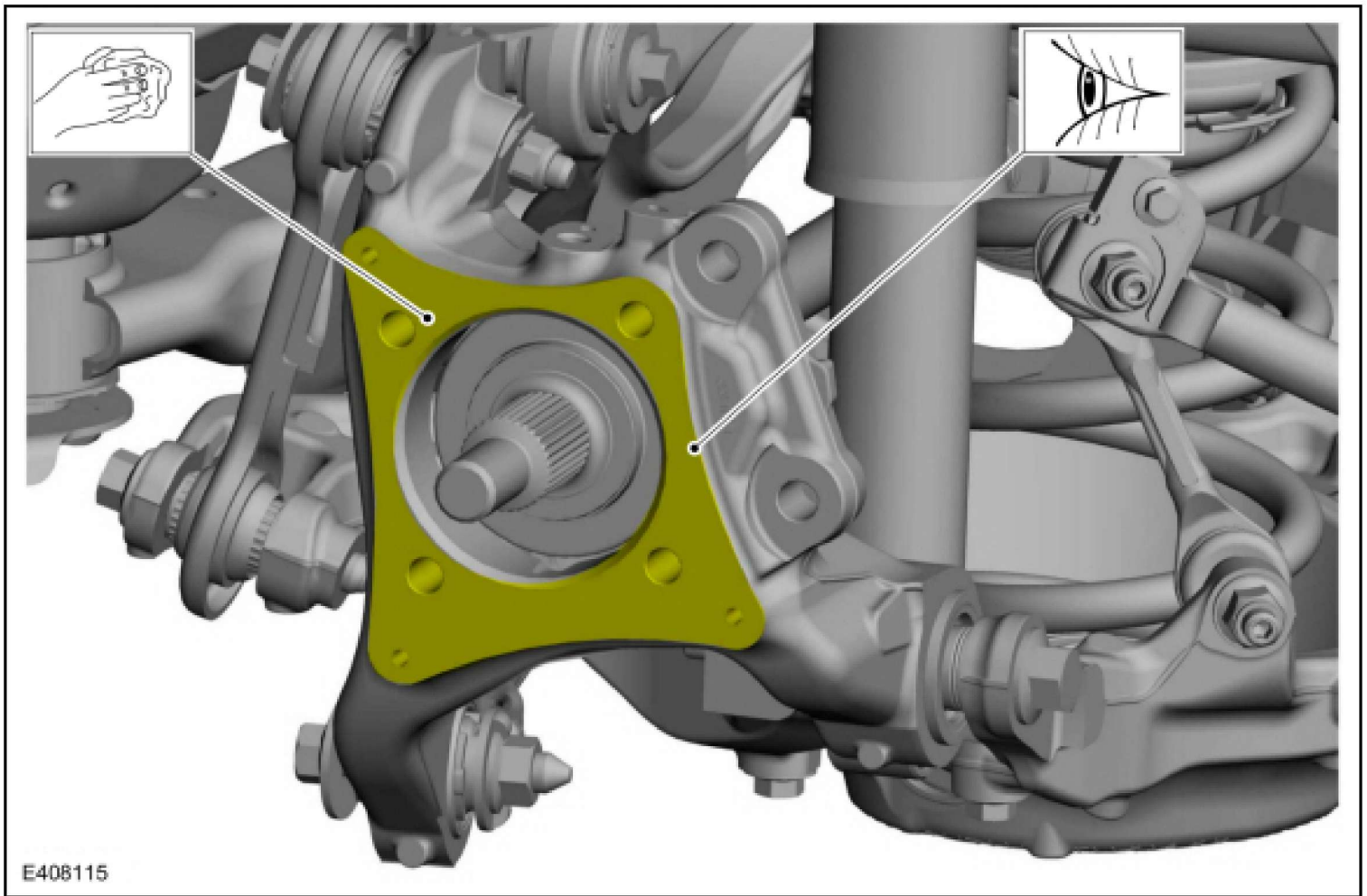

2. **NOTE:** *Tighten the wheel bearing and wheel hub bolts in a cross pattern.*

Position the wheel bearing and wheel hub and install the new wheel bearing and wheel hub bolts.
Torque : 85 lb.ft (115 Nm)

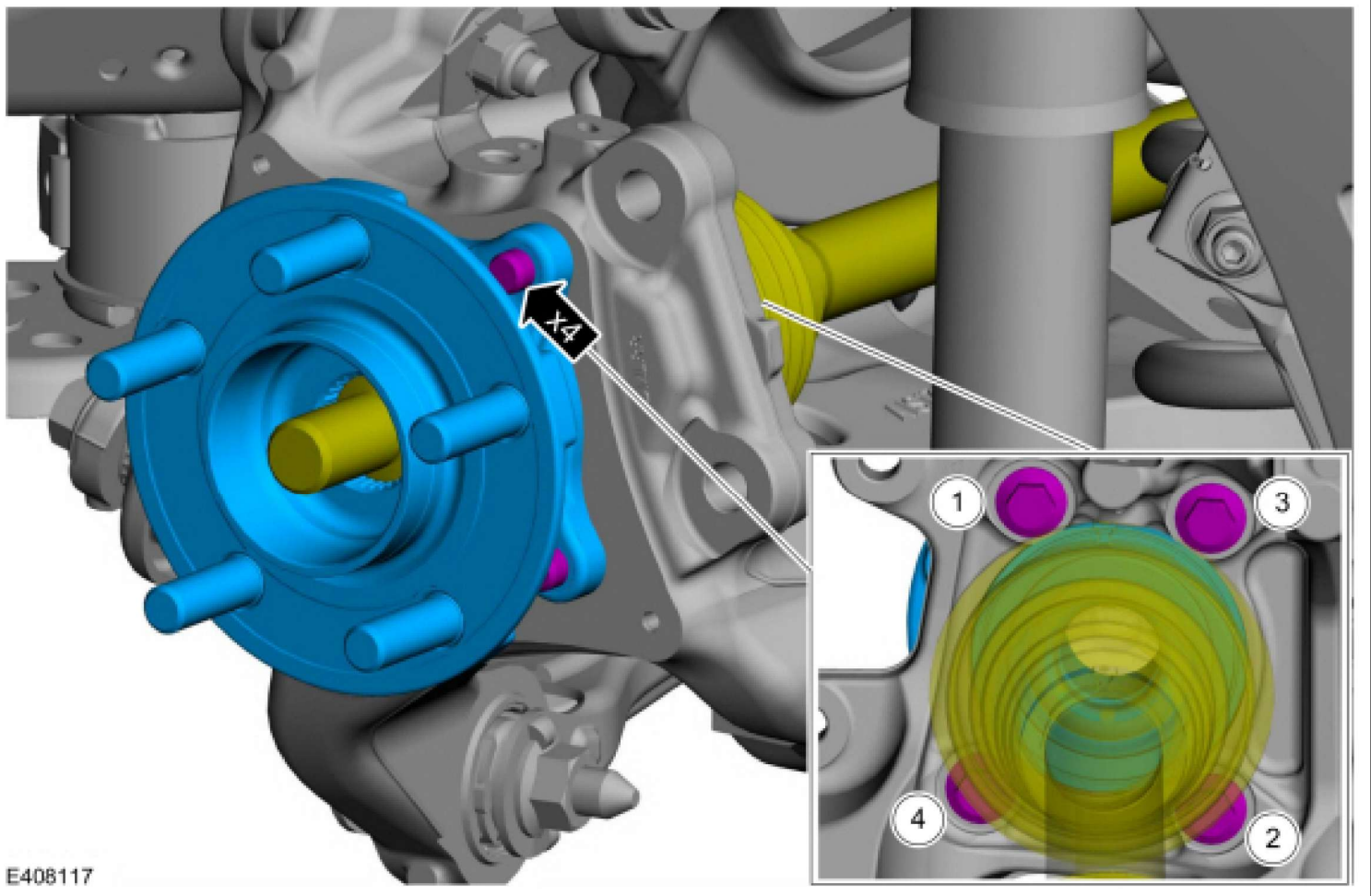

E408117

3. Position the wheel speed sensor and install the front wheel speed sensor bolt.
Torque : 80 lb.in (9 Nm)

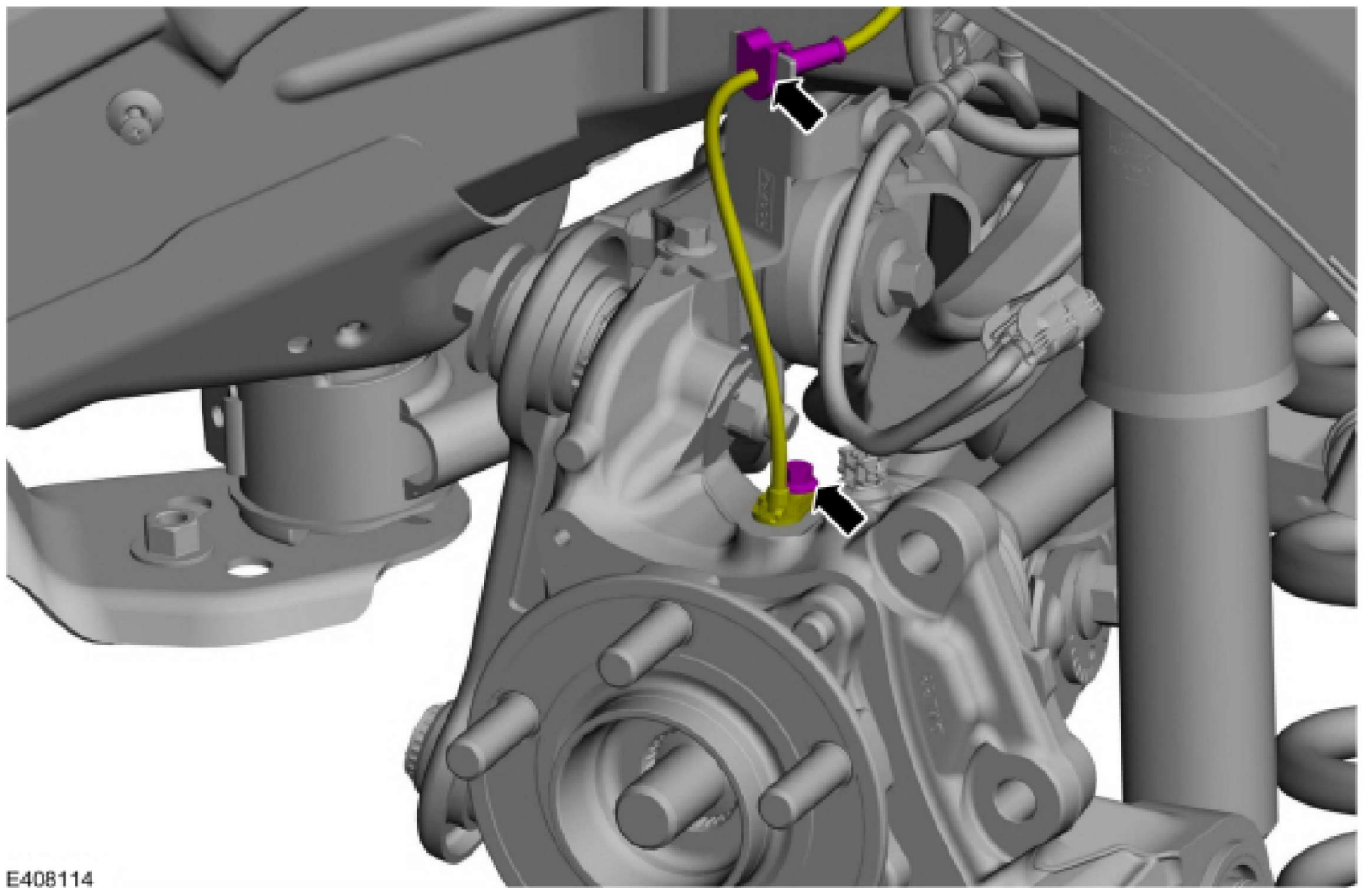

4. Install the brake disc shield.

Refer to: [Brake Disc Shield](#) (206-04 Rear Disc Brake, Removal and Installation) .

5. **NOTICE: Install and tighten the new wheel hub nut to specification in a continuous rotation. Always install a new wheel hub nut after loosening or when not tightened to specification in a continuous rotation or damage to the components may occur.**

NOTE: *Apply the brake to keep the halfshaft from rotating.*

While an assistant applies the brake, install the new wheel hub nut.

Torque :

Stage 1: 85 lb.ft (115 Nm)

Stage 2: 30°

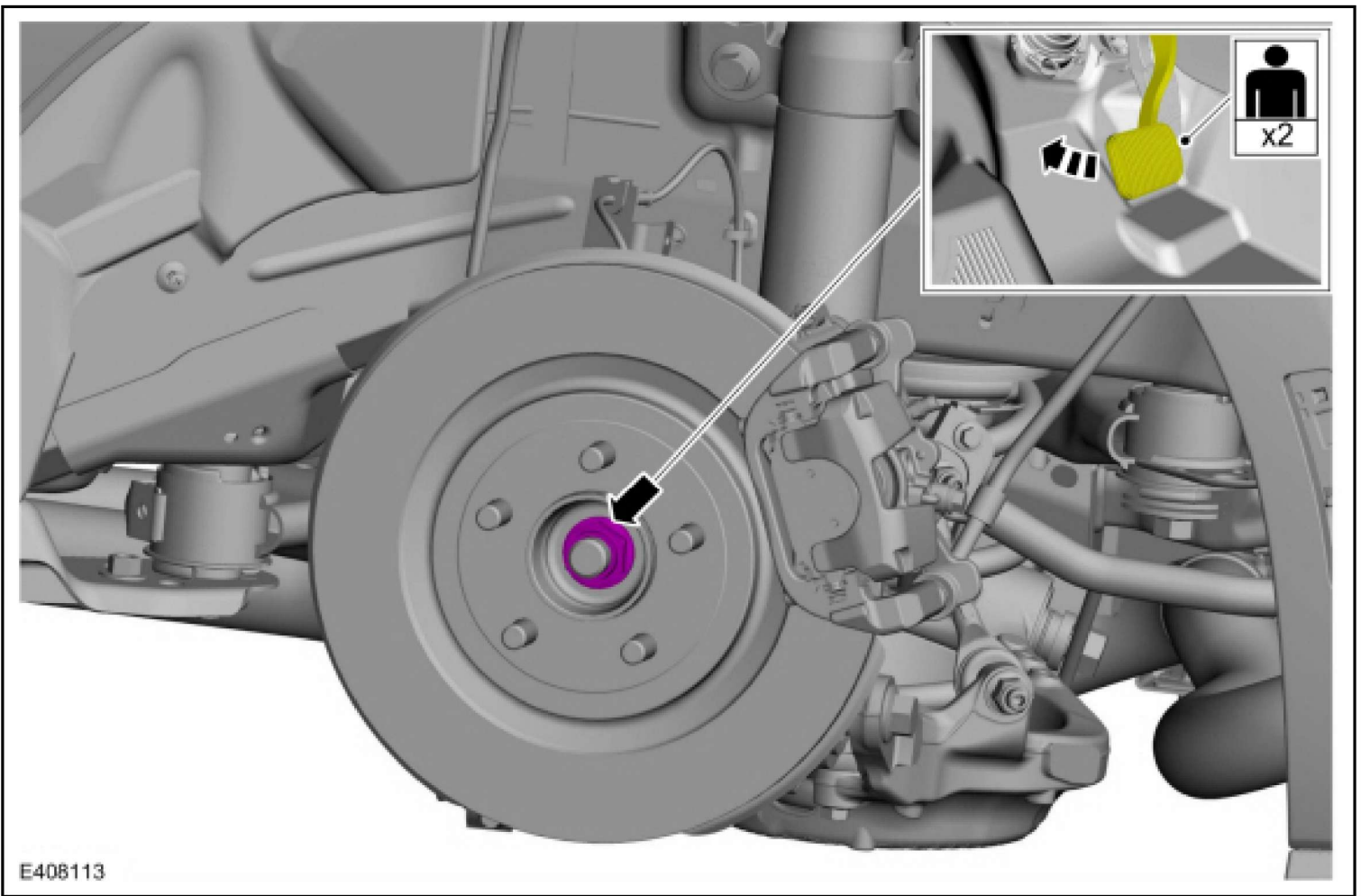

6. Install the wheel and tire.

Refer to: [Wheel and Tire](#) (204-04A Wheels and Tires, Removal and Installation) .

© Copyright 2025, Ford Motor Company.

Wheel Bearing and Wheel Hub - Dark Horse/GT



Special Tool(s) / General Equipment

	205-D070 (D93P-1175-B) Remover, Front Wheel Hub
--	---

Removal

NOTICE: Suspension fasteners are critical parts that affect the performance of vital components and systems. Failure of these fasteners may result in major service expense. Use the same or equivalent parts if replacement is necessary. Do not use a replacement part of lesser quality or substitute design. Tighten fasteners as specified.

1. Remove the wheel and tire.
Refer to: [Wheel and Tire](#) (204-04A Wheels and Tires, Removal and Installation) .
2. Remove and discard the spindle nut.

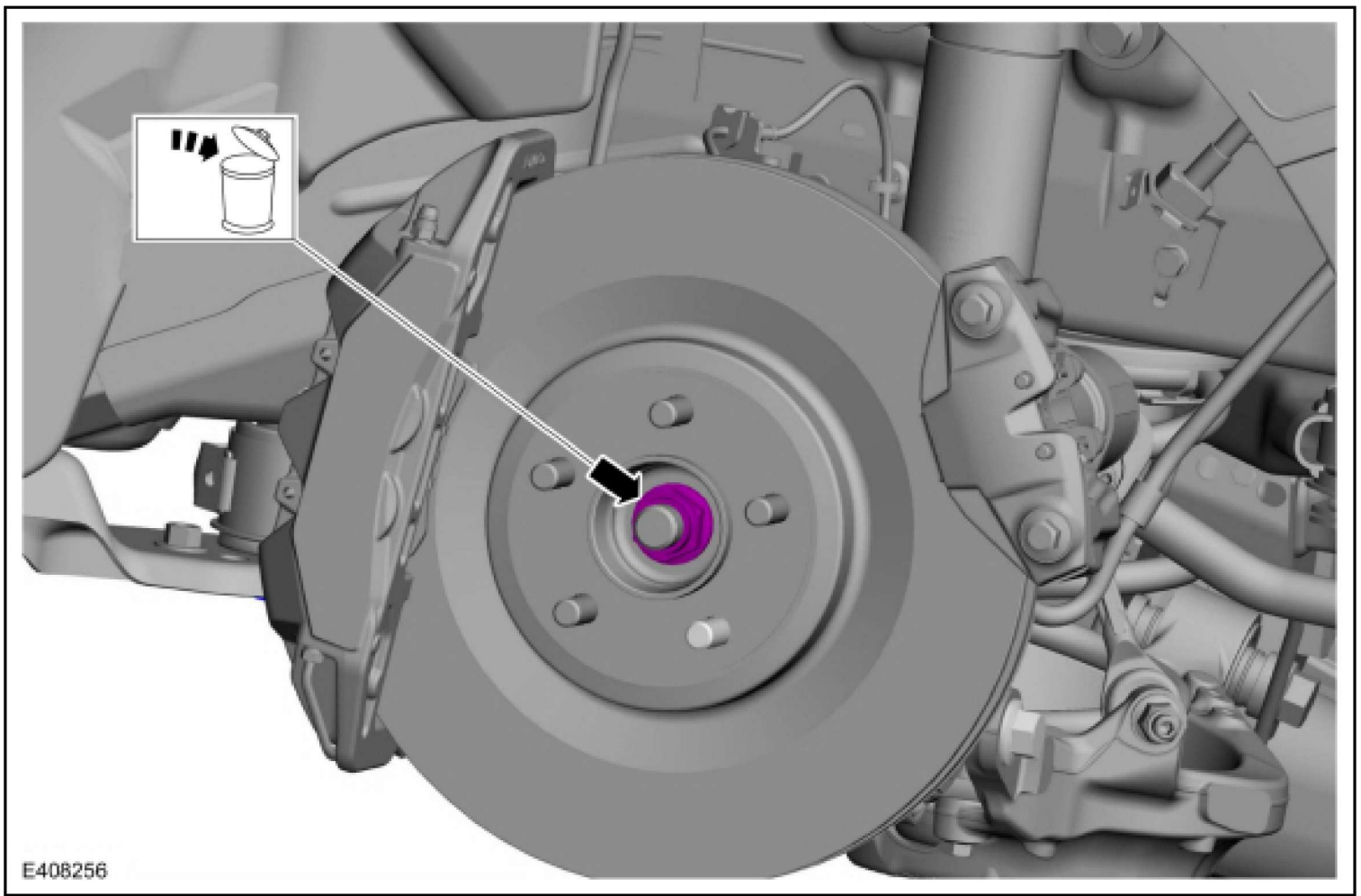

3. **NOTE:** *Push the halfshaft into the wheel hub to gain access for the removal of the wheel bearing and wheel hub bolts.*

Using the special tool, press the halfshaft from the front wheel bearing and hub.
Use Special Service Tool: 205-D070 (D93P-1175-B) Remover, Front Wheel Hub .

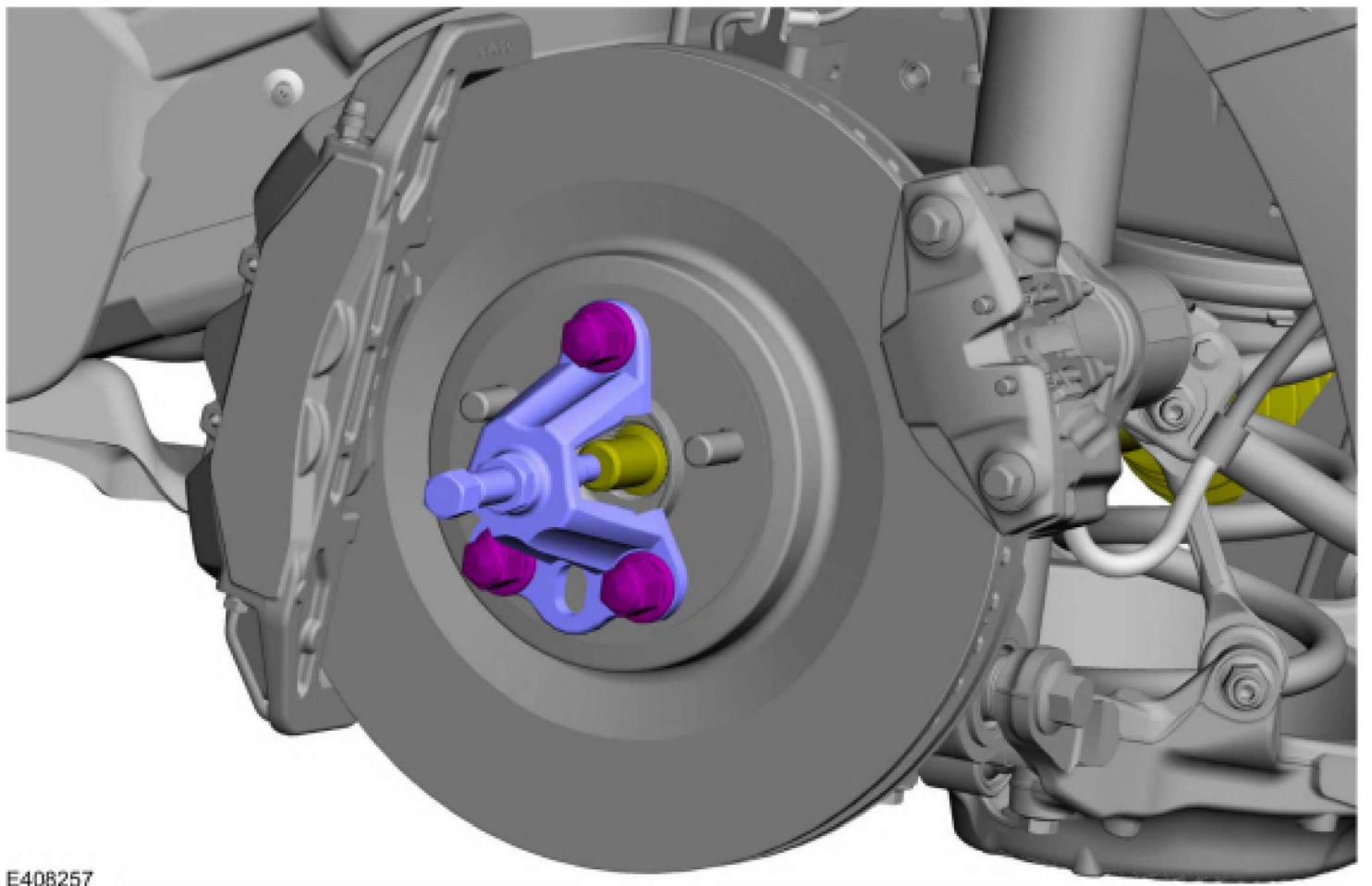

4. Remove the brake disc.

Refer to: [Brake Disc - Dark Horse, Vehicles With: EcoBoost™ Performance Package/GT Performance Package](#) (206-04 Rear Disc Brake, Removal and Installation) .

5. Remove the bolt and position aside the front wheel speed sensor.

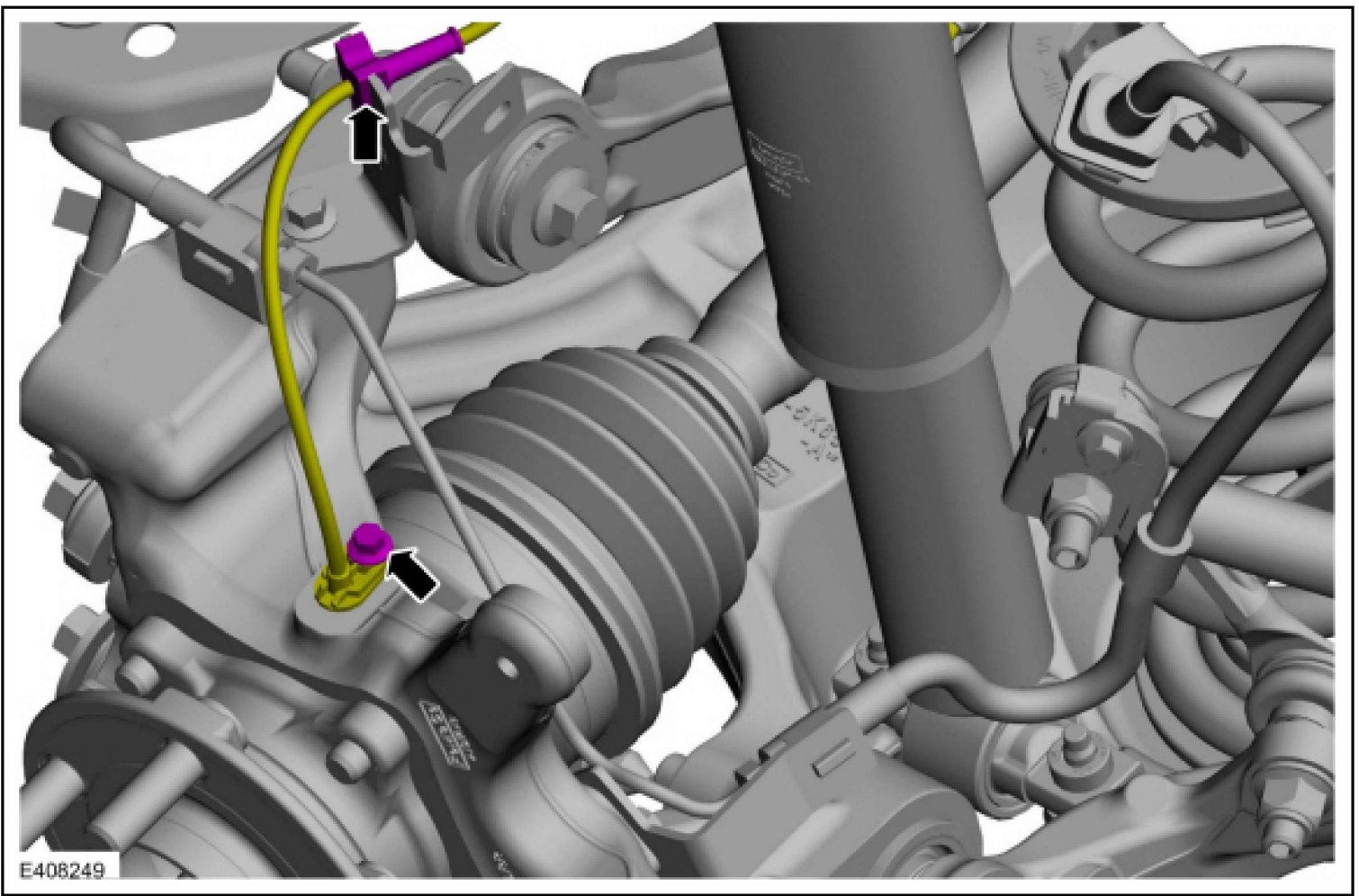

6. Remove and discard the 4 wheel bearing and wheel hub bolts and remove the wheel bearing and wheel hub.

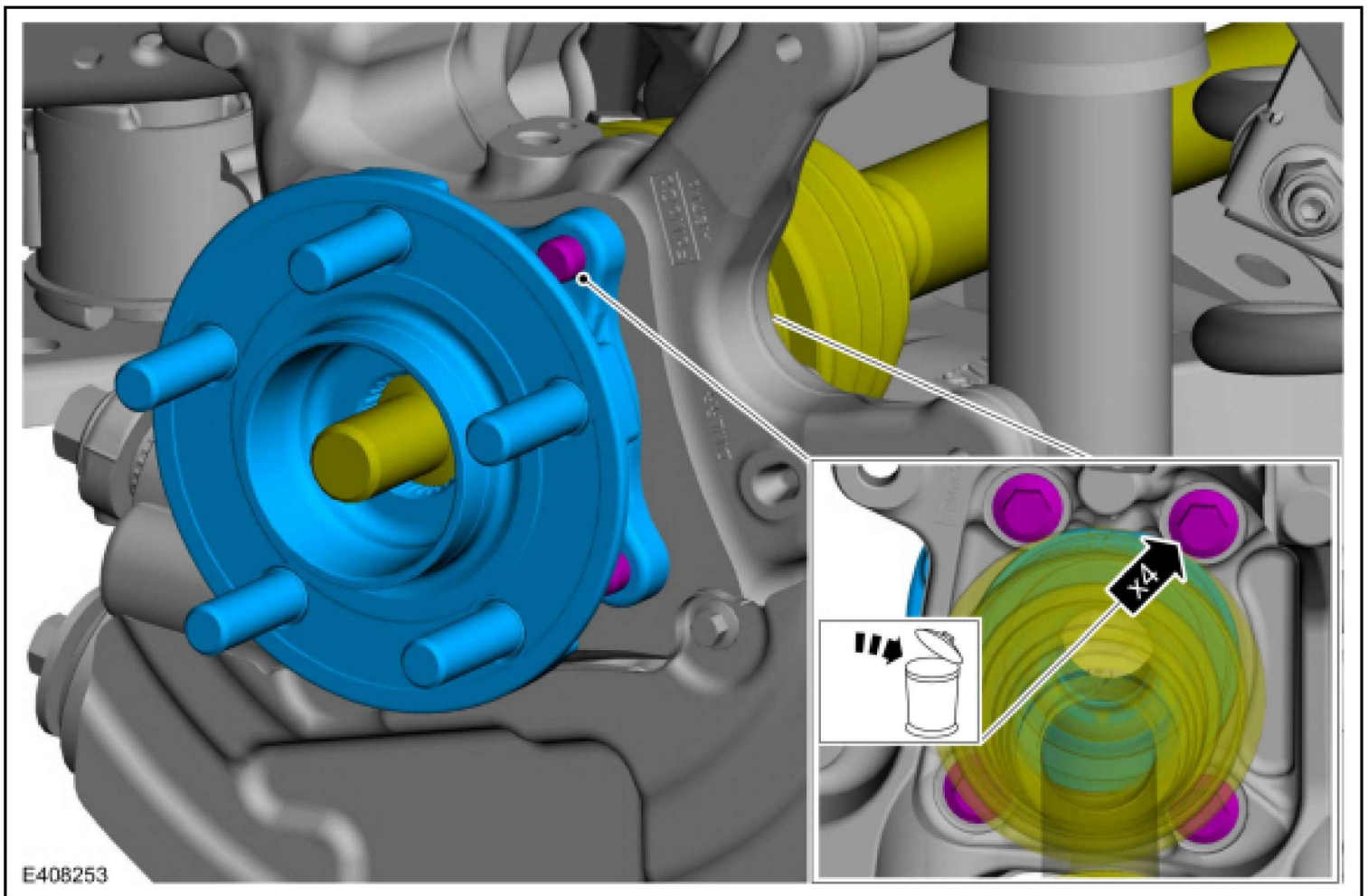

Installation

NOTICE: The wheel knuckle bore must be clean enough to allow the wheel bearing and wheel hub to seat completely by hand. Do not press or draw the wheel hub and bearing into place or damage to the bearing may occur.

NOTICE: Make sure the wheel hub-to-wheel knuckle mating surfaces are clean and free of any adhesive. Failure to clean the adhesive from both surfaces may cause bearing damage.

1. Clean and inspect the wheel hub-to-wheel knuckle mating surfaces.

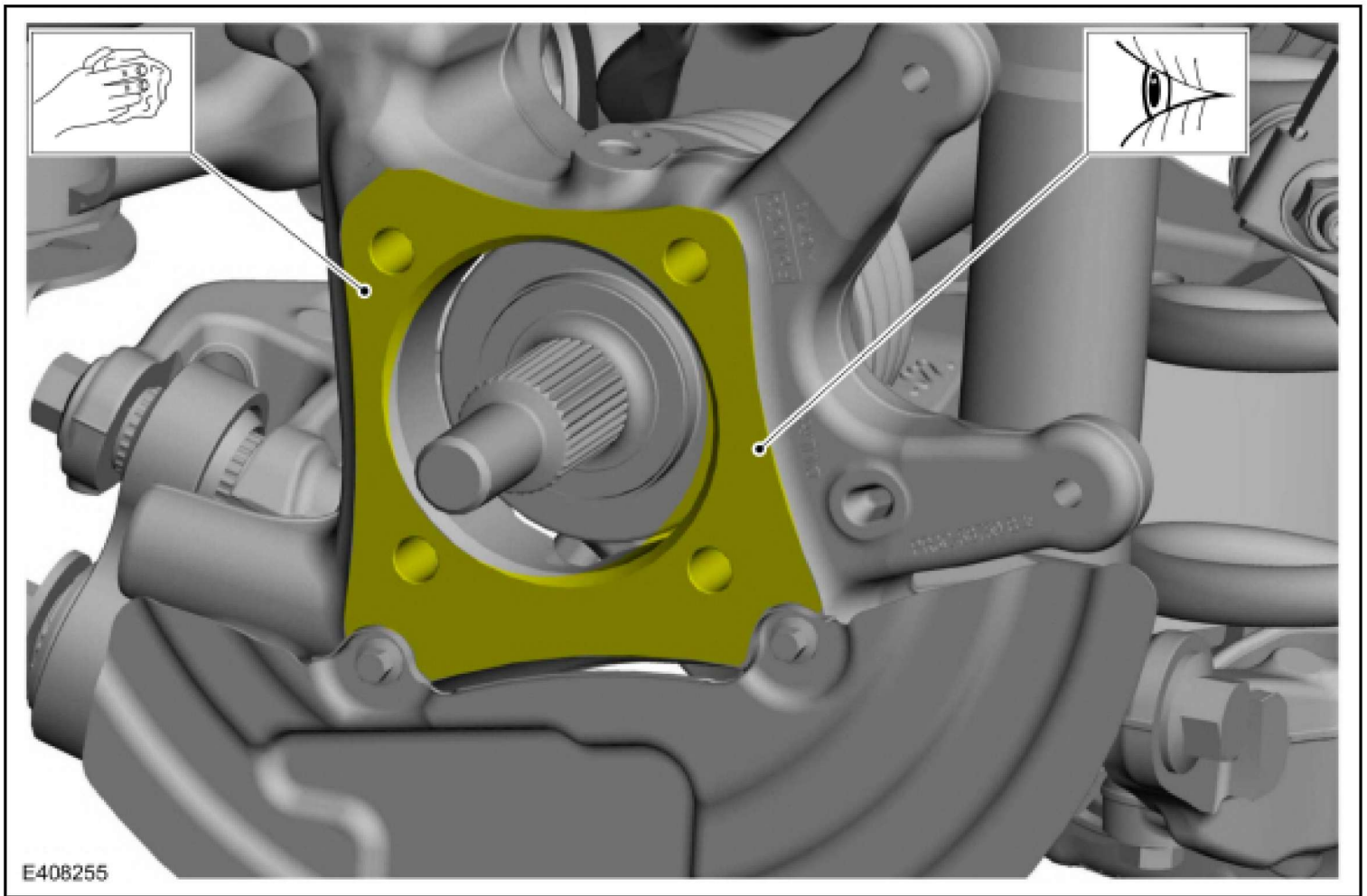

2. **NOTE:** *Tighten the wheel bearing and wheel hub bolts in a cross pattern.*

Position the wheel bearing and wheel hub and install the 4 new wheel bearing and wheel hub bolts.
Torque : 85 lb.ft (115 Nm)

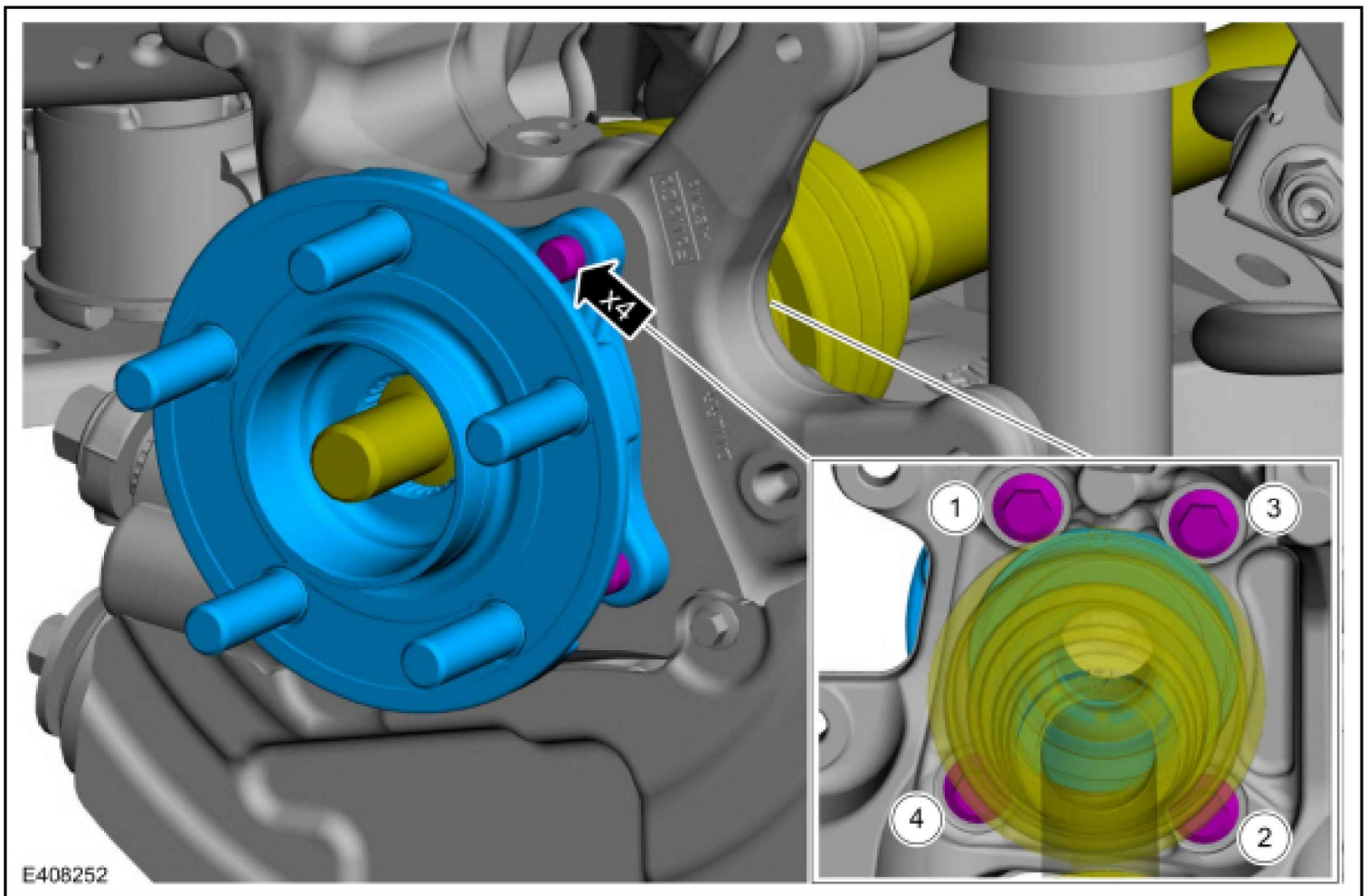

3. Position the wheel speed sensor and install the front wheel speed sensor bolt.
Torque : 80 lb.in (9 Nm)



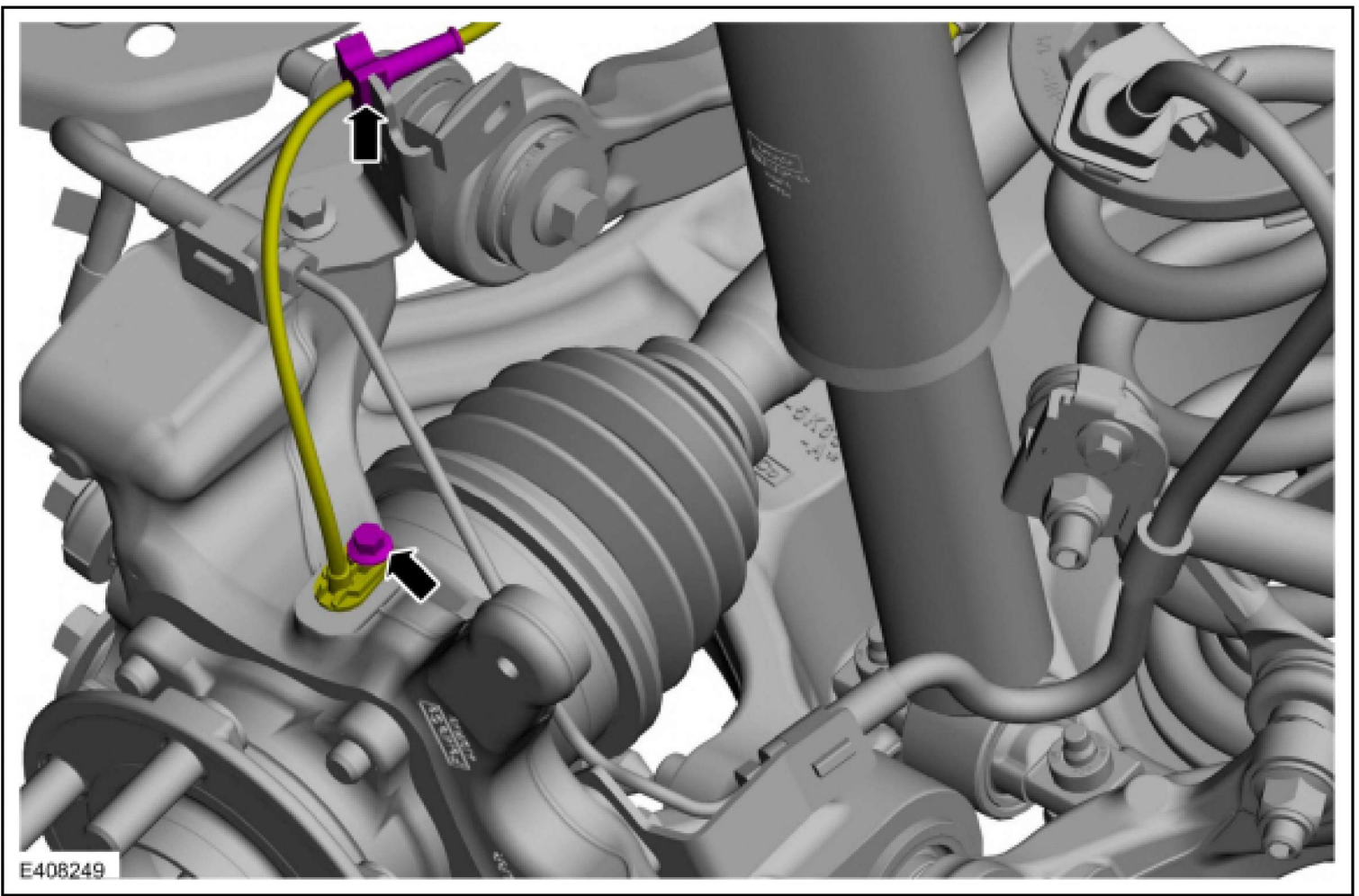

4. Install the brake disc.

Refer to: [Brake Disc - Dark Horse, Vehicles With: EcoBoost™ Performance Package/GT Performance Package](#) (206-04 Rear Disc Brake, Removal and Installation) .

5. **NOTICE: Install and tighten the new wheel hub nut to specification in a continuous rotation. Always install a new wheel hub nut after loosening or when not tightened to specification in a continuous rotation or damage to the components may occur.**

NOTE: *Apply the brake to keep the halfshaft from rotating.*

While an assistant applies the brake, install the new wheel hub nut.

Torque :

Stage 1: 85 lb.ft (115 Nm)

Stage 2: 30°

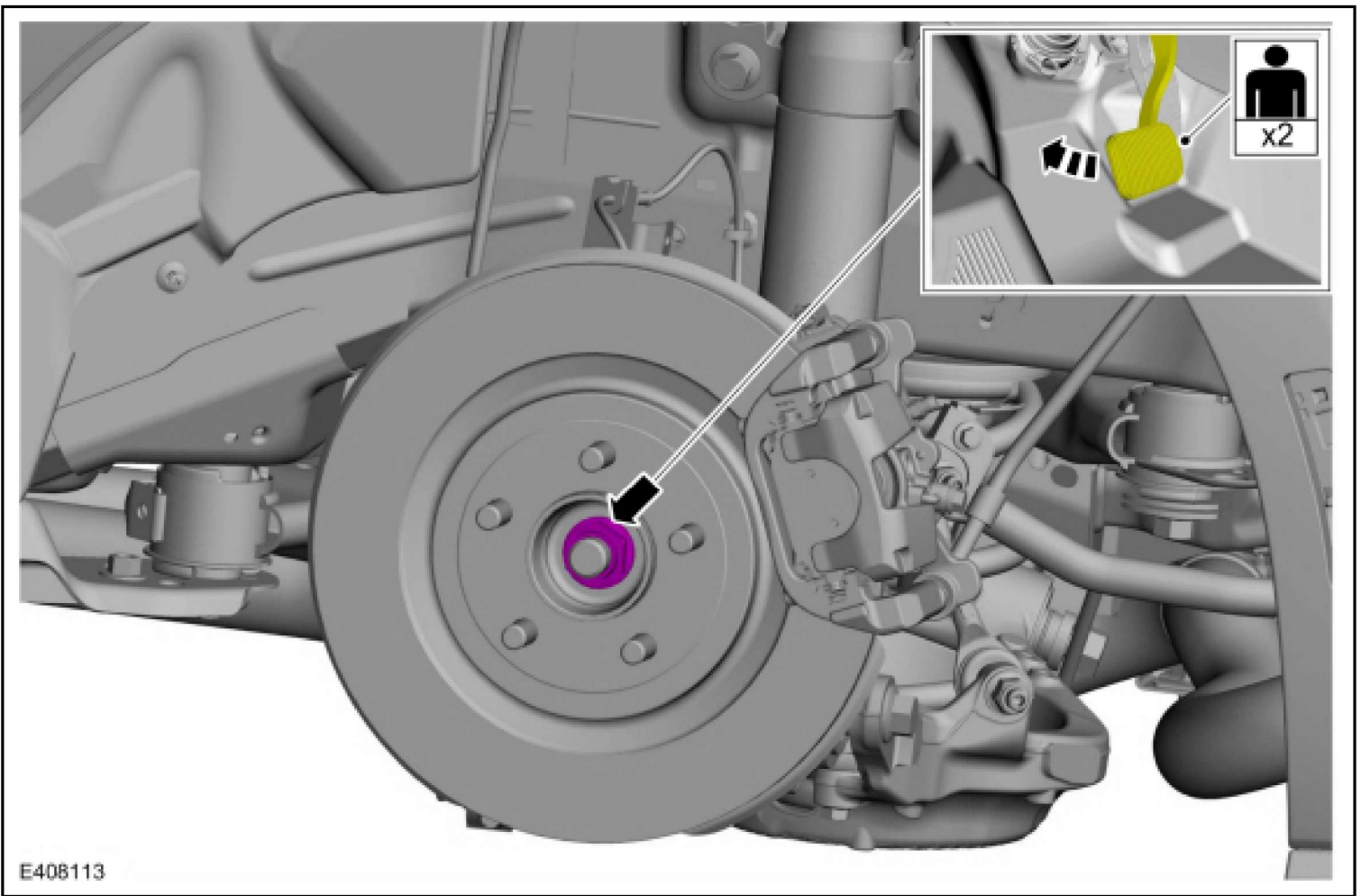

6. Install the wheel and tire.

Refer to: [Wheel and Tire](#) (204-04A Wheels and Tires, Removal and Installation) .

© Copyright 2025, Ford Motor Company.

Wheel Knuckle



Removal

NOTICE: Suspension fasteners are critical parts that affect the performance of vital components and systems. Failure of these fasteners may result in major service expense. Use the same or equivalent parts if replacement is necessary. Do not use a replacement part of lesser quality or substitute design. Tighten fasteners as specified.

1. Remove the wheel bearing and wheel hub.

Refer to: [Wheel Bearing and Wheel Hub](#) (204-02 Rear Suspension, Removal and Installation) .

1. Remove the wheel speed sensor bolt and position aside the wheel speed sensor.
2. Disconnect the parking brake cable retainer.
3. Remove the parking brake cable bracket bolt and position the parking brake cable bracket aside.

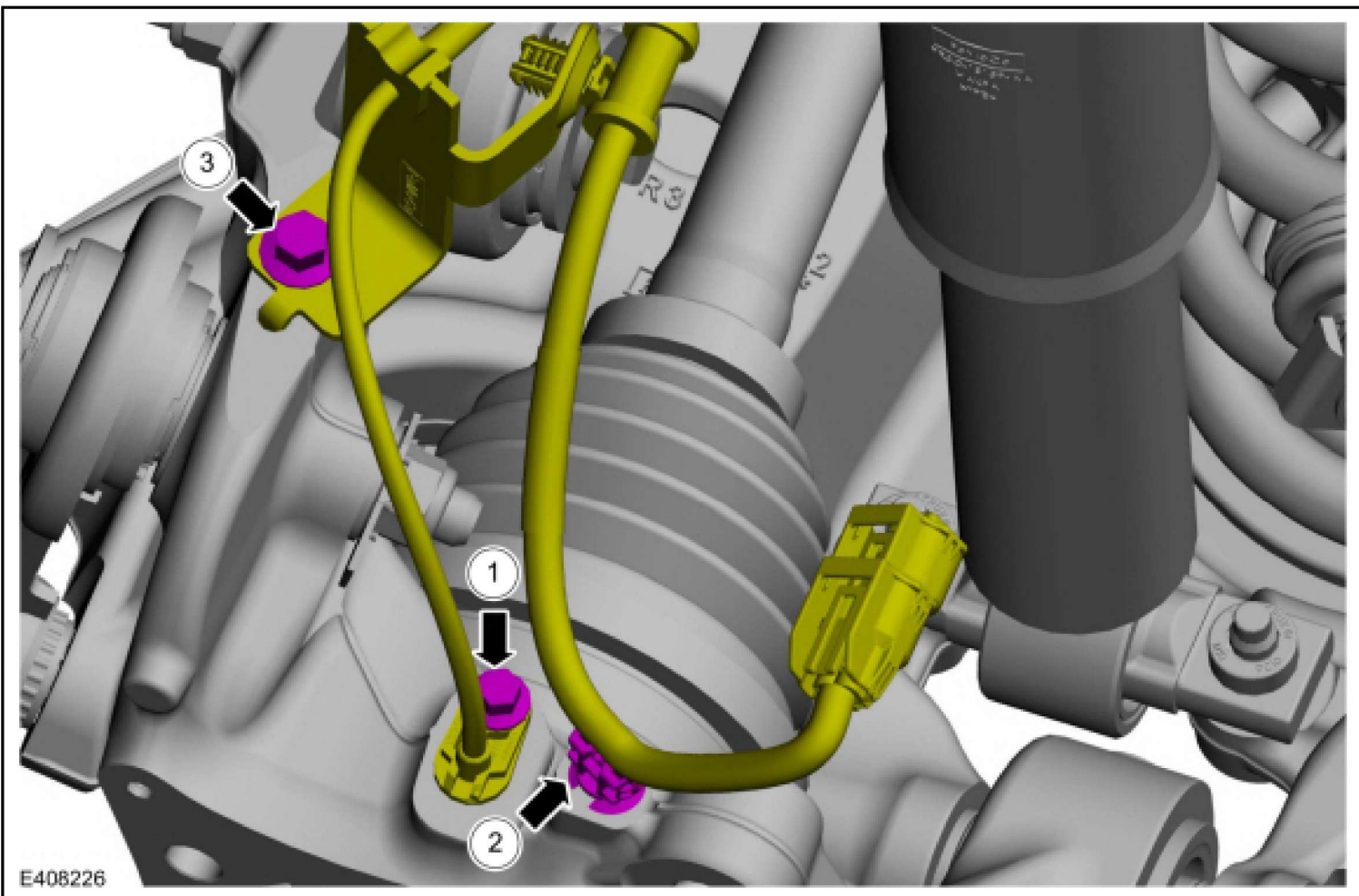

3. Support the suspension at curb height.

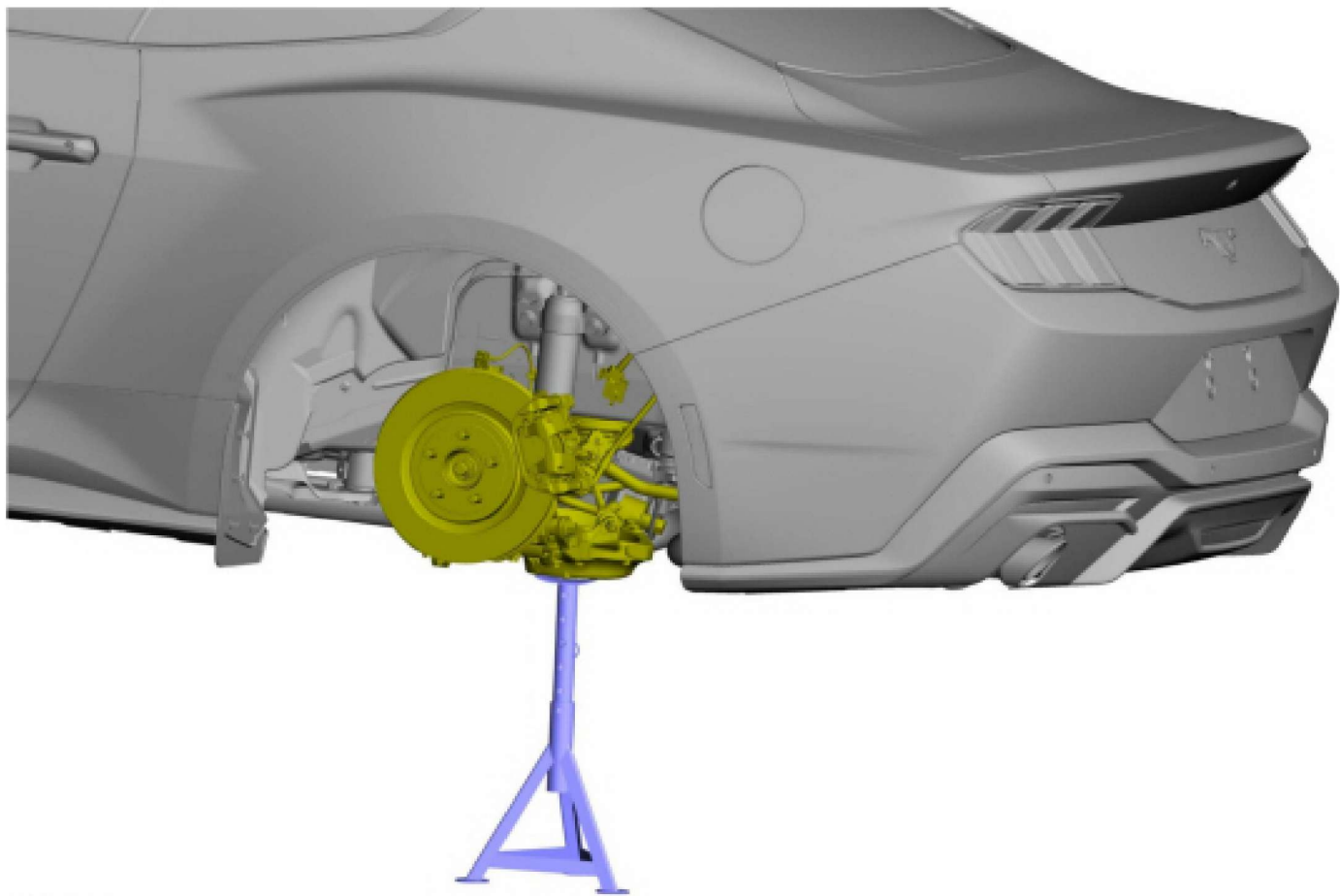

E408028



4. Remove the lower arm vertical link.

Refer to: [Lower Arm Vertical Link](#) (204-02 Rear Suspension, Removal and Installation) .

5. **NOTE:** *Support the halfshaft.*

1. Remove and discard the wheel knuckle-to-upper arm bolt and nut.
2. Remove and discard the wheel knuckle-to-toe link bolt and nut.
3. Remove and discard the wheel knuckle-to-lower arm bolt. Remove the knuckle.

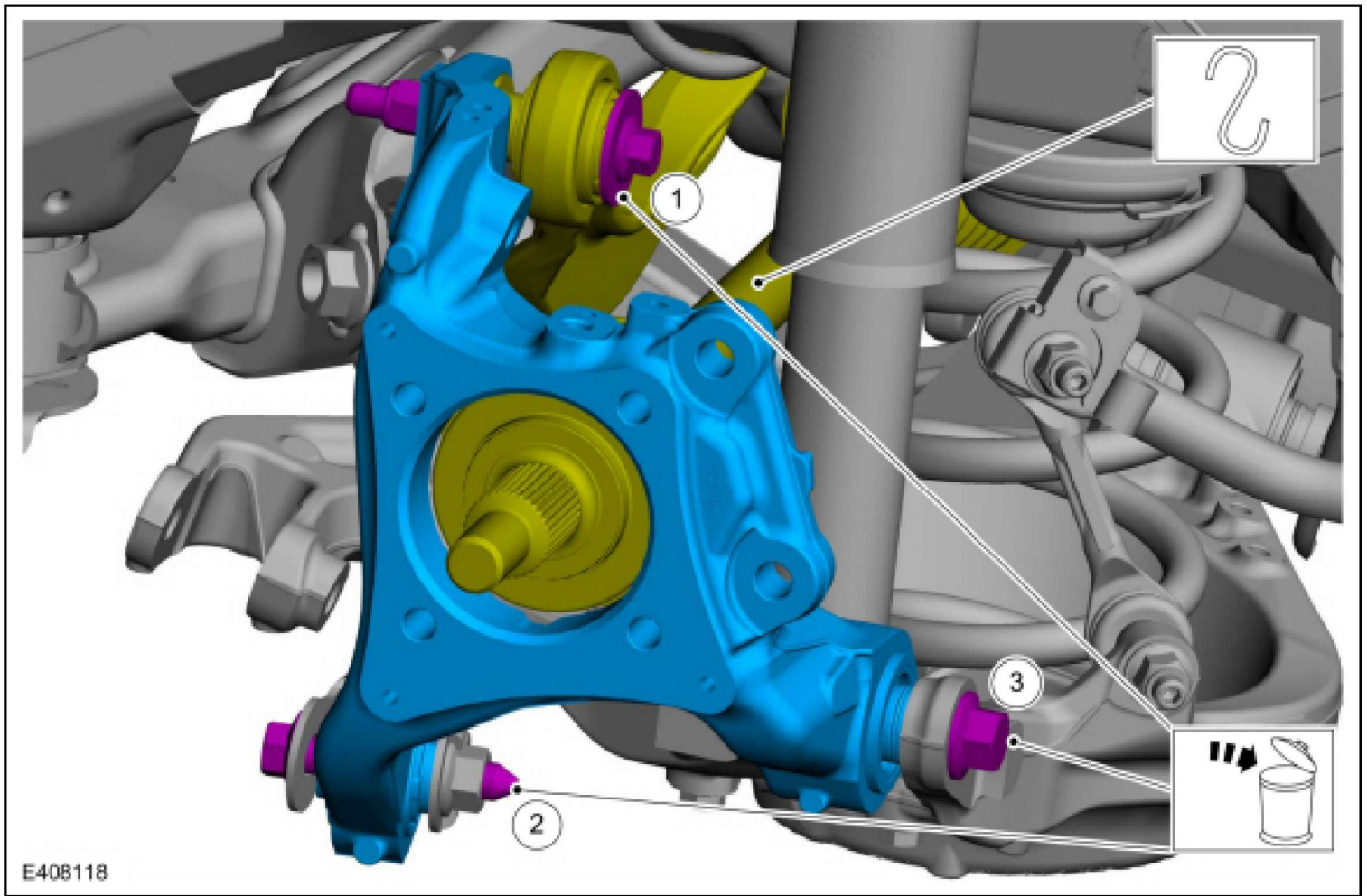

Installation

NOTICE: Tighten the suspension bushing fasteners with the suspension loaded or with the weight of the vehicle resting on the wheels and tires, otherwise incorrect clamp load and bushing damage may occur.

1. Position the wheel knuckle and install the new wheel knuckle-to-lower arm bolt.
Torque : 203 lb.ft (275 Nm)
2. Install the new wheel knuckle-to-toe link bolt.
Torque : 129 lb.ft (175 Nm)
3. Install the new wheel knuckle-to-upper arm bolt and nut.
Torque : 76 lb.ft (103 Nm)

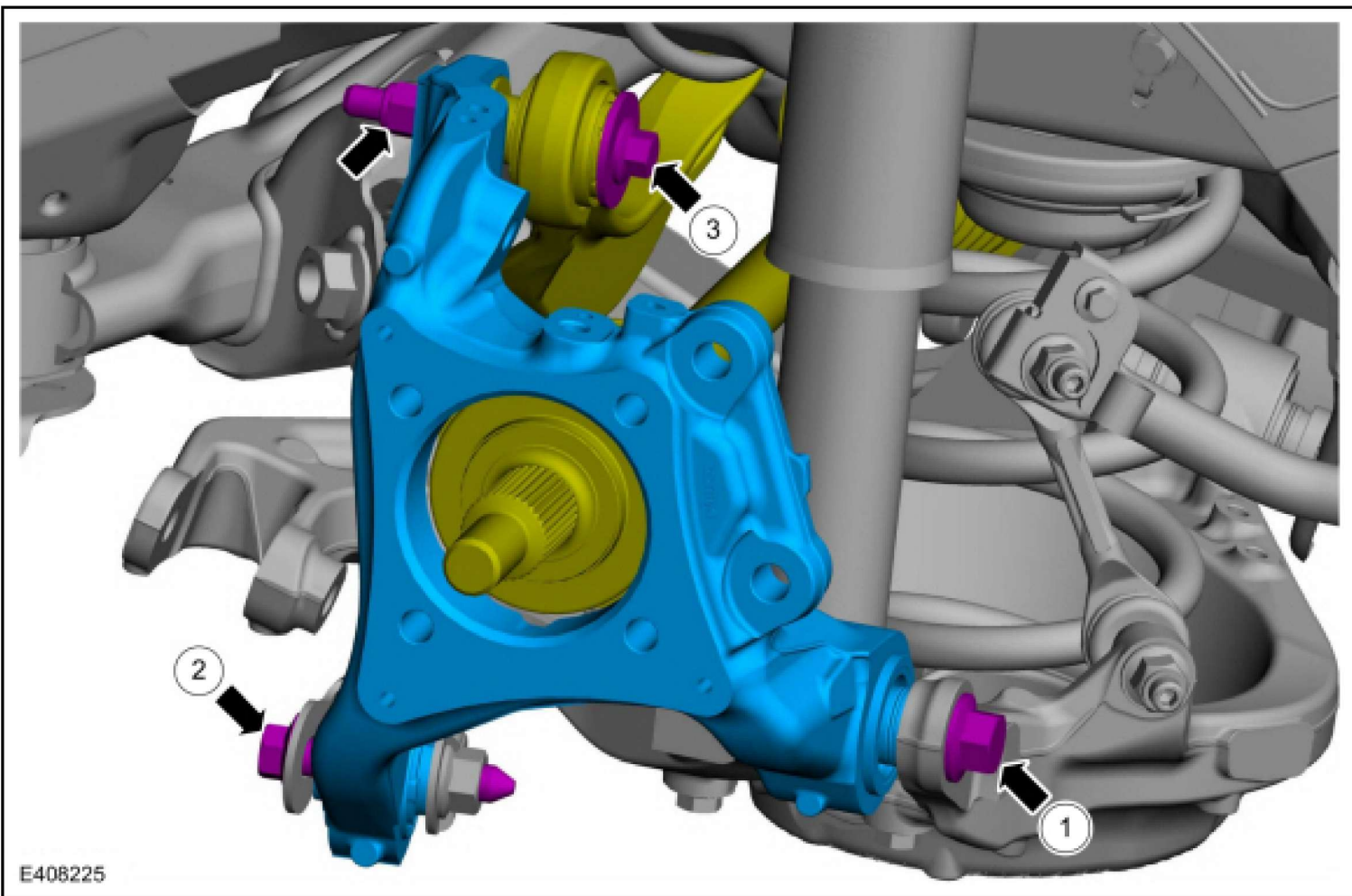

1. Position the wheel speed sensor and install the wheel speed sensor bolt.
Torque : 80 lb.in (9 Nm)
2. Position the parking brake cable and connect the retainer.
3. Position the parking brake cable bracket and install the parking brake cable bracket bolt.
Torque : 21 lb.ft (28 Nm)

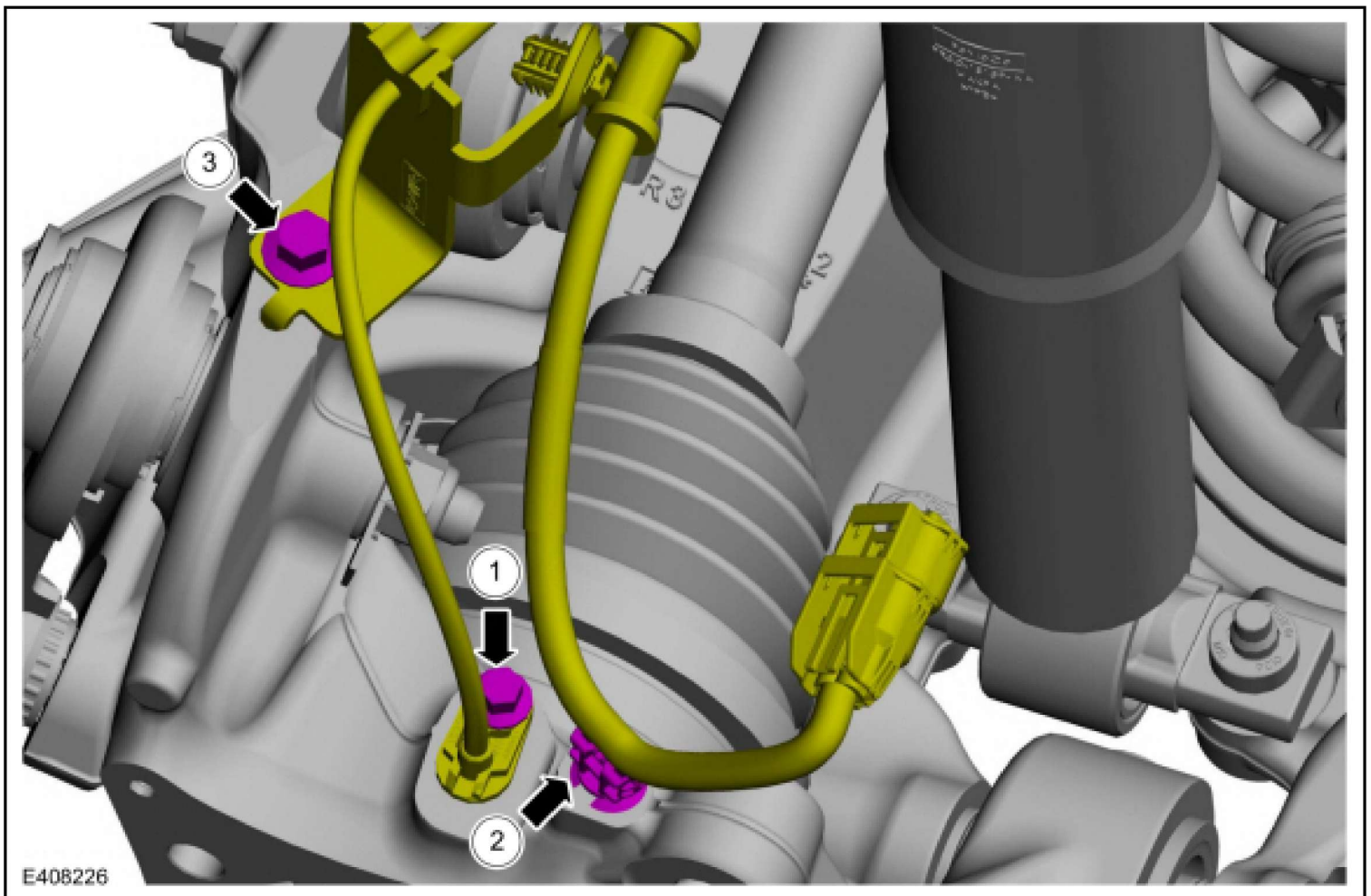

3. Install the lower arm vertical link.

Refer to: [Lower Arm Vertical Link](#) (204-02 Rear Suspension, Removal and Installation) .

4. Install the wheel bearing and wheel hub.

Refer to: [Wheel Bearing and Wheel Hub](#) (204-02 Rear Suspension, Removal and Installation) .

5. Check and if necessary adjust rear toe.

Refer to: [Rear Toe Adjustment](#) (204-00 Suspension System - General Information, General Procedures) .

Wheel Knuckle - Dark Horse/GT



Removal

NOTICE: Suspension fasteners are critical parts that affect the performance of vital components and systems. Failure of these fasteners may result in major service expense. Use the same or equivalent parts if replacement is necessary. Do not use a replacement part of lesser quality or substitute design. Tighten fasteners as specified.

1. Remove the wheel bearing and wheel hub.

Refer to: [Wheel Bearing and Wheel Hub - Dark Horse/GT](#) (204-02 Rear Suspension, Removal and Installation) .

- Remove the brake hose bracket bolt and position the brake hose bracket.
- Remove the brake hose bracket bolt mounted on knuckle and position the brake hose bracket aside.

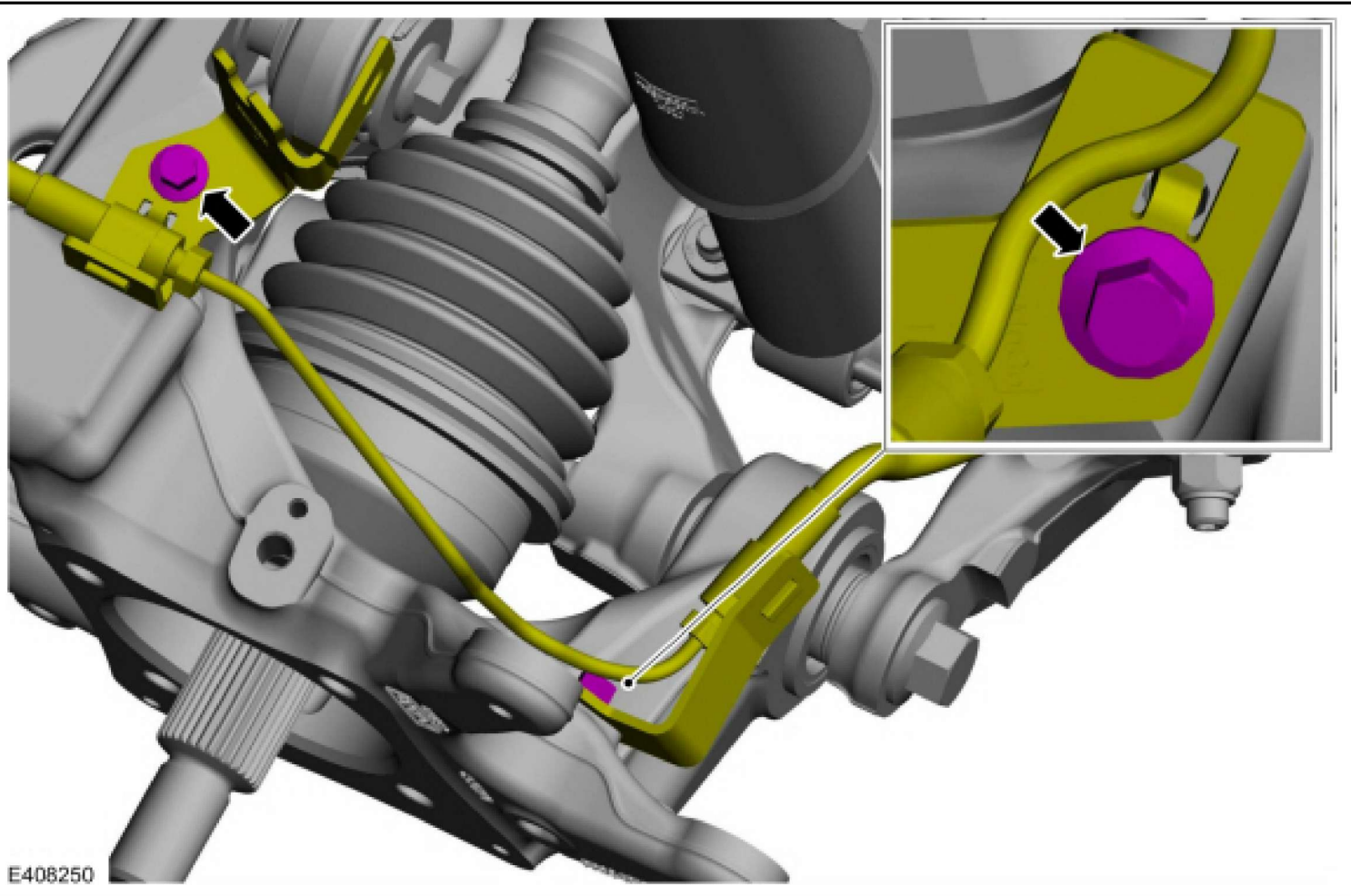

3. Support the suspension at curb height.



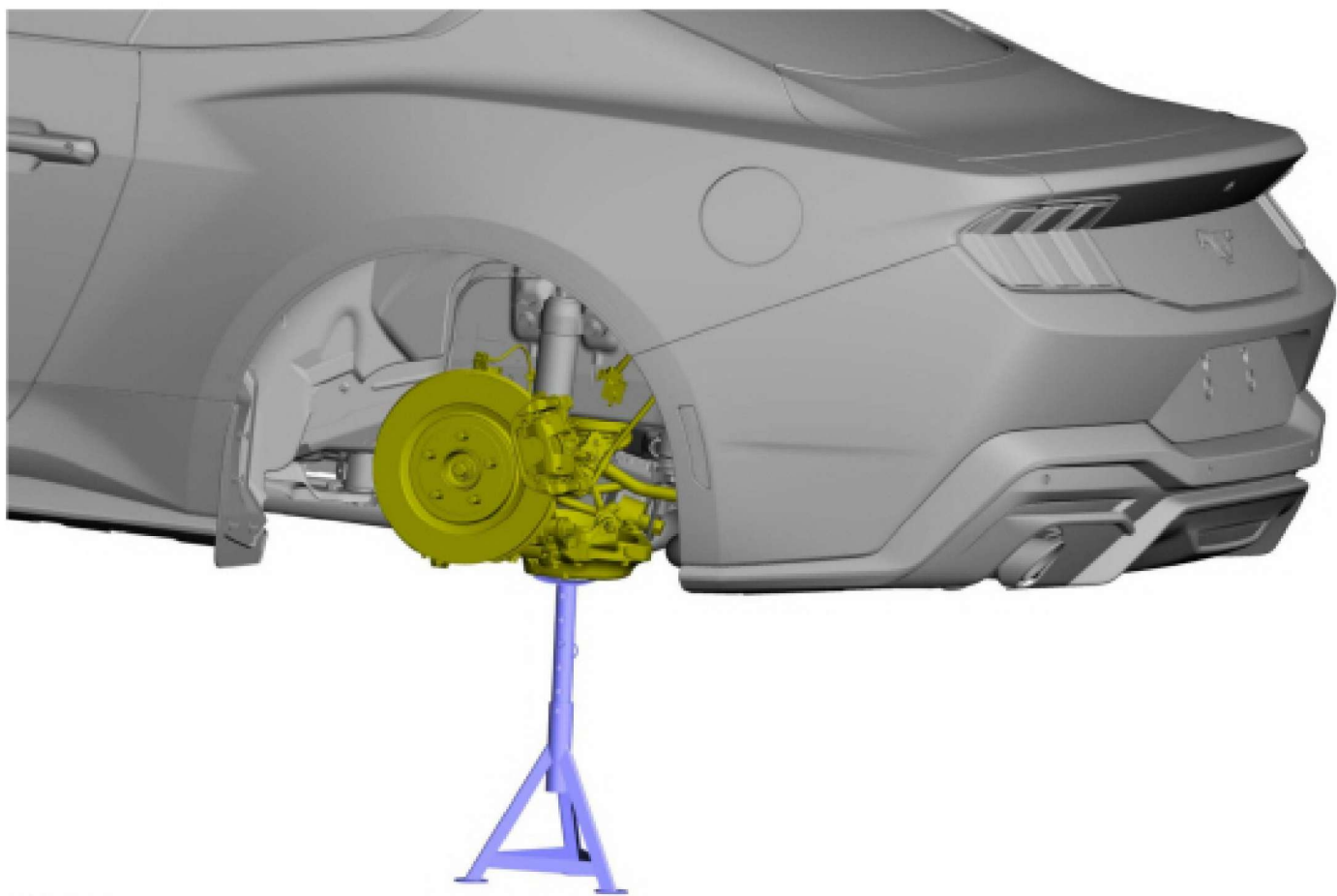

E408028

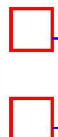

- Remove and discard the lower arm vertical link lower bolt and nut.
- Remove and discard the toe link-to-wheel knuckle bolt.

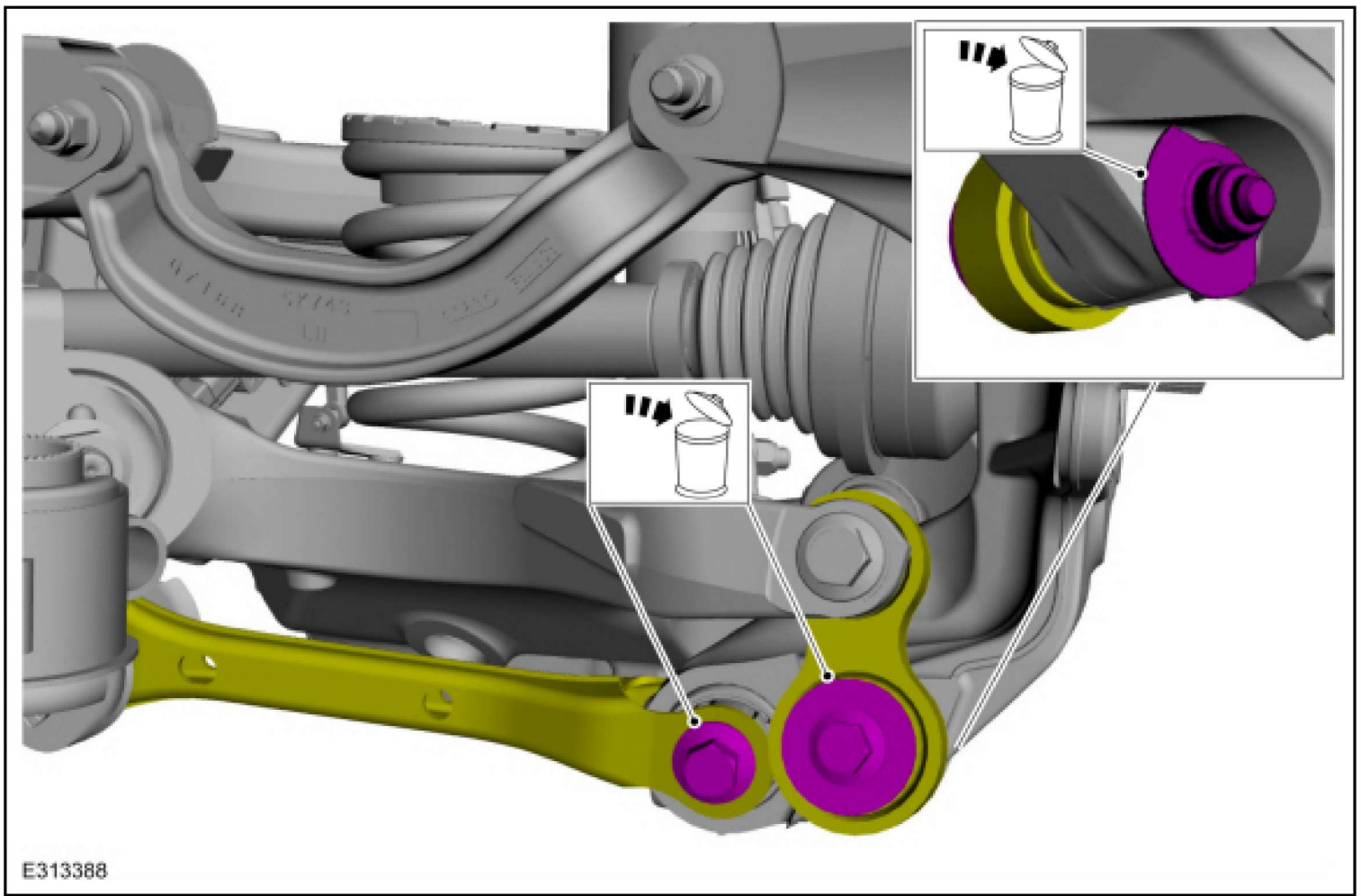

1. Remove and discard the wheel knuckle-to-upper arm bolt and nut.
2. Remove and discard the wheel knuckle-to-lower arm bolt.
3. Support the halfshaft and remove the wheel knuckle.

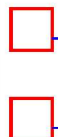
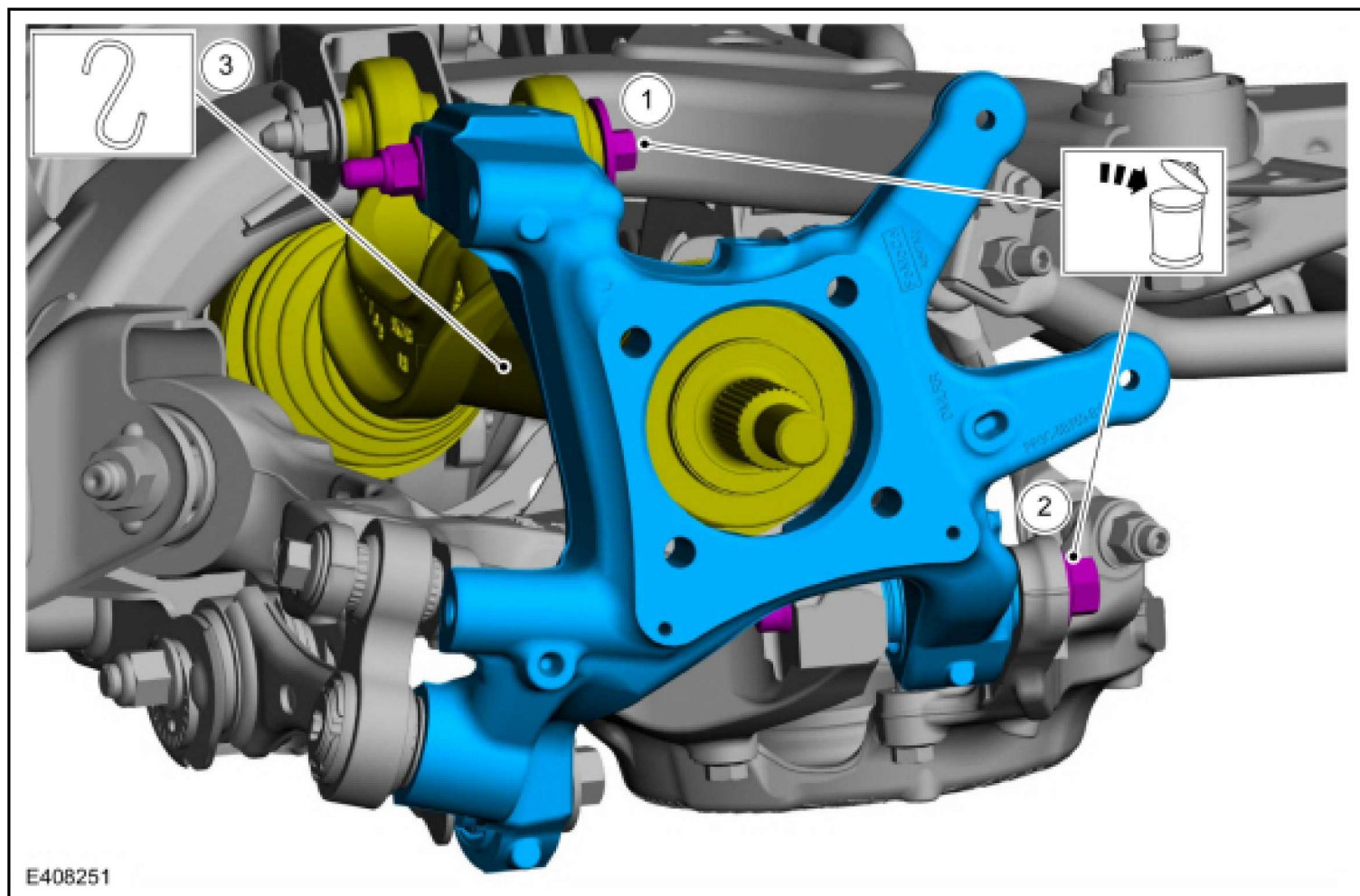

Installation

NOTICE: Tighten the suspension fasteners with the weight of the vehicle on the wheels and tires or use a suitable jack to raise the suspension to curb height or damage to the bushings may occur.

1. Position the wheel knuckle and install the new wheel knuckle-to-lower arm bolt.
Torque : 203 lb.ft (275 Nm)
2. Install the new wheel knuckle-to-upper arm bolt and nut.
Torque : 76 lb.ft (103 Nm)

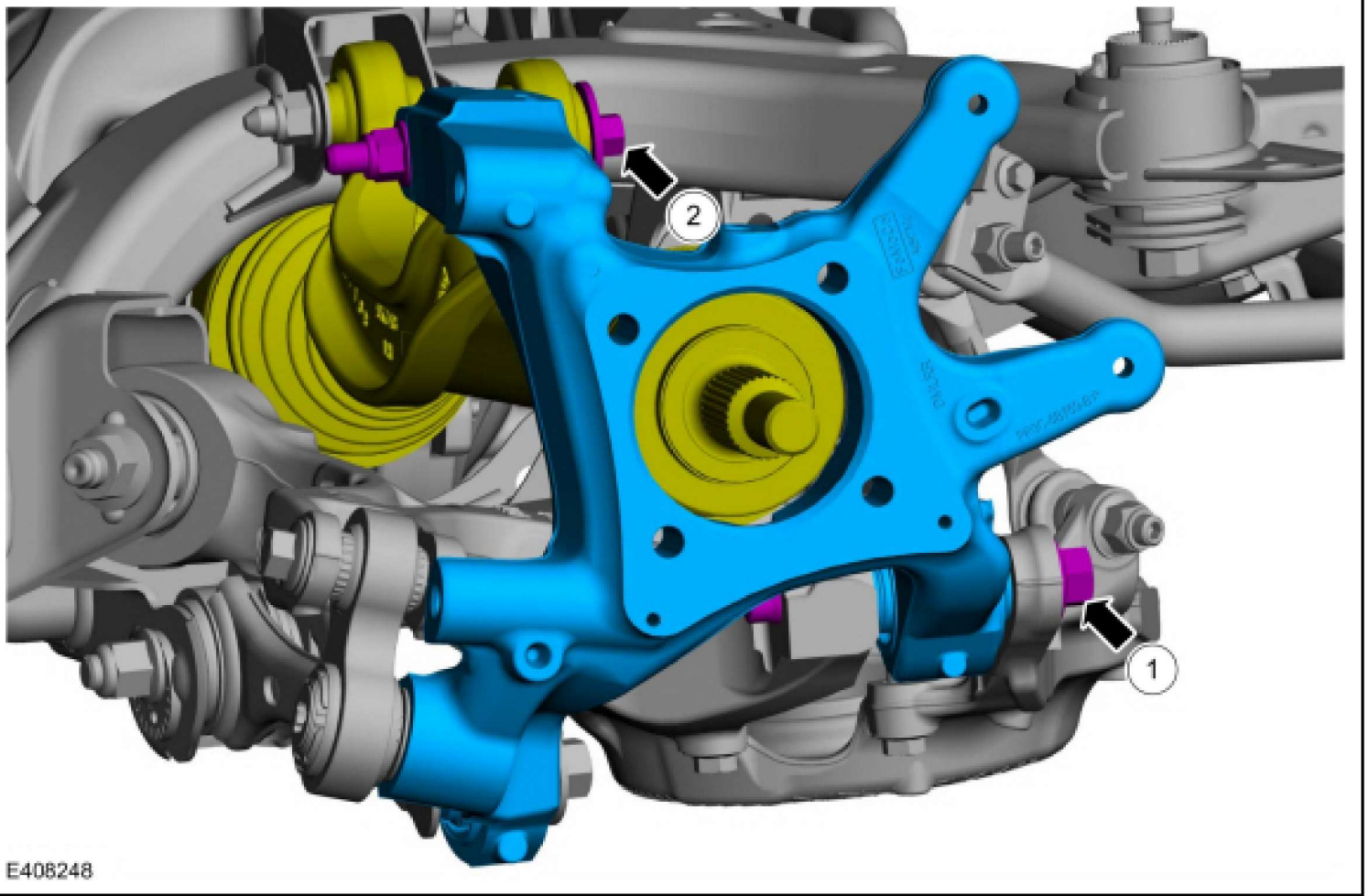

1. Position the lower arm vertical link and install the new lower arm vertical link lower bolt and nut.
Torque : 76 lb.ft (103 Nm)
2. Position the toe link and install the new toe link-to-knuckle bolt.
Torque : 129 lb.ft (175 Nm)

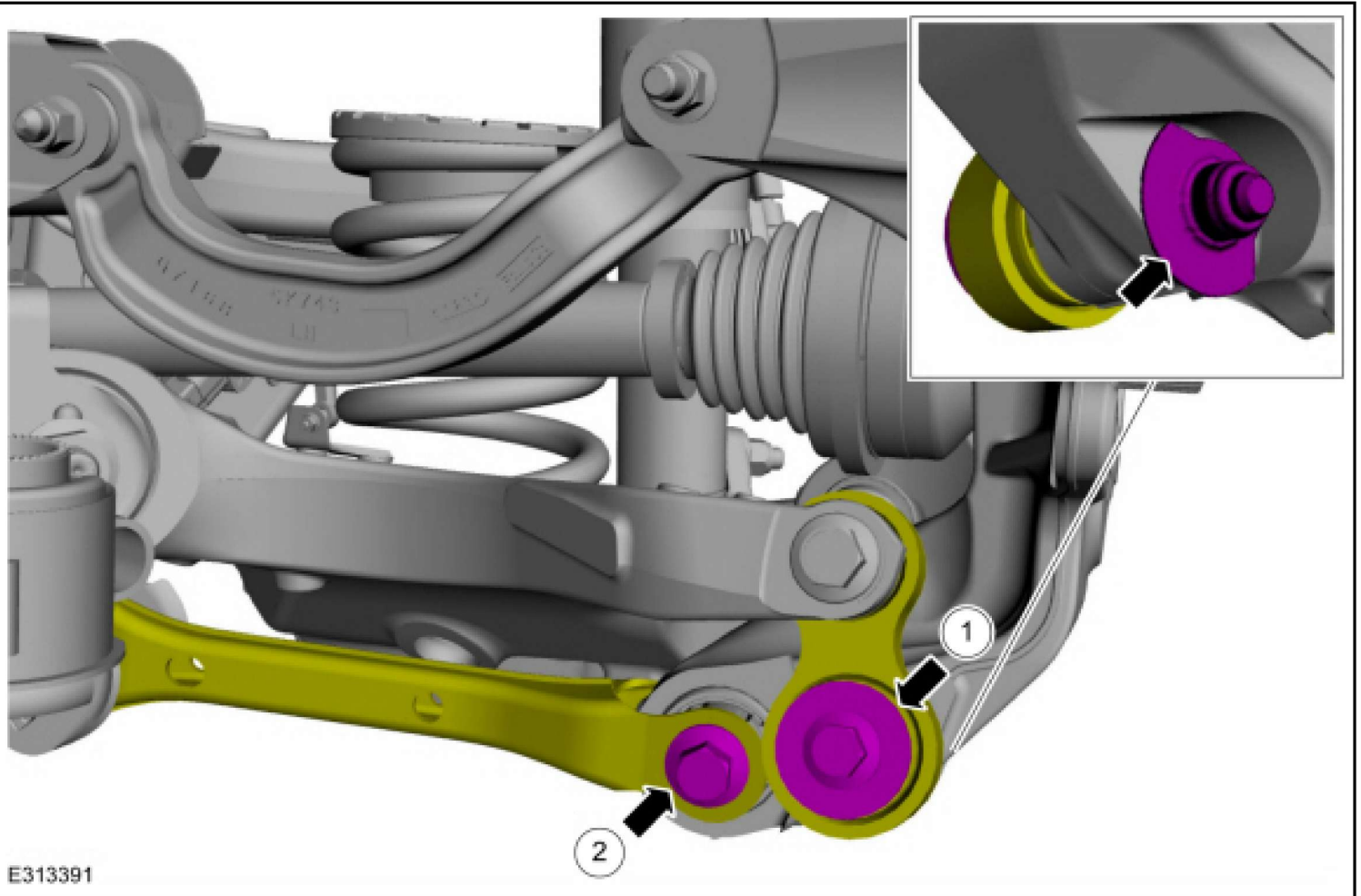

- Position the brake hose bracket and install the brake hose bracket bolt.
Torque : 26 lb.ft (35 Nm)
- Position the brake hose bracket and install the brake hose bracket bolt mounted on knuckle.
Torque : 26 lb.ft (35 Nm)



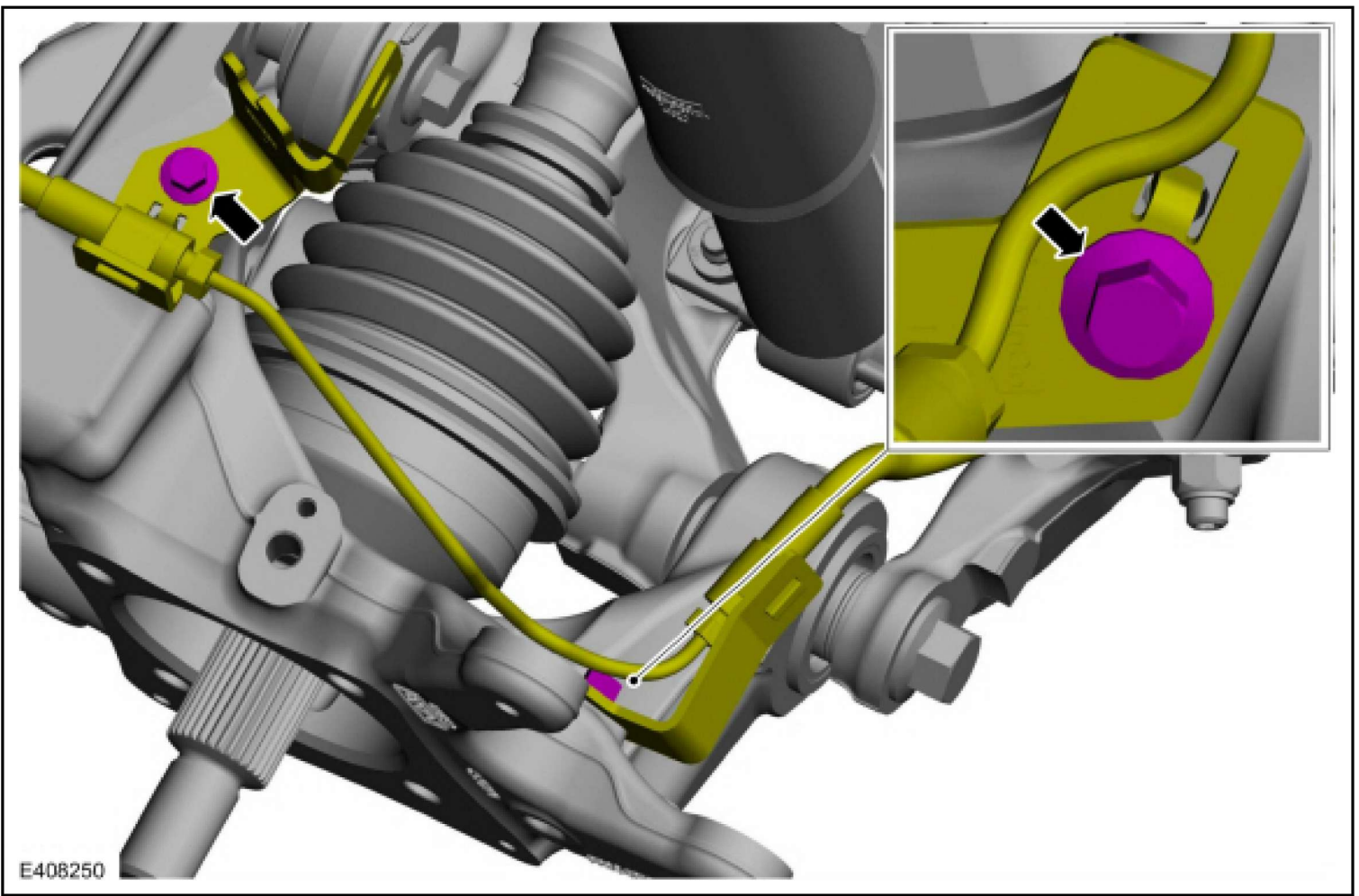

4. Install the wheel bearing and wheel hub.

Refer to: [Wheel Bearing and Wheel Hub - Dark Horse/GT](#) (204-02 Rear Suspension, Removal and Installation) .

5. Check and if necessary adjust rear toe.

Refer to: [Rear Toe Adjustment](#) (204-00 Suspension System - General Information, General Procedures) .

Wheel Studs



Special Tool(s) / General Equipment

Hydraulic Press

Removal

1. Remove the wheel bearing and wheel hub.
Refer to: [Wheel Bearing and Wheel Hub](#) (204-02 Rear Suspension, Removal and Installation) .
Refer to: [Wheel Bearing and Wheel Hub - Dark Horse/GT](#) (204-02 Rear Suspension, Removal and Installation) .
2. Press the wheel stud from the wheel bearing and wheel hub.
Use the General Equipment: Hydraulic Press

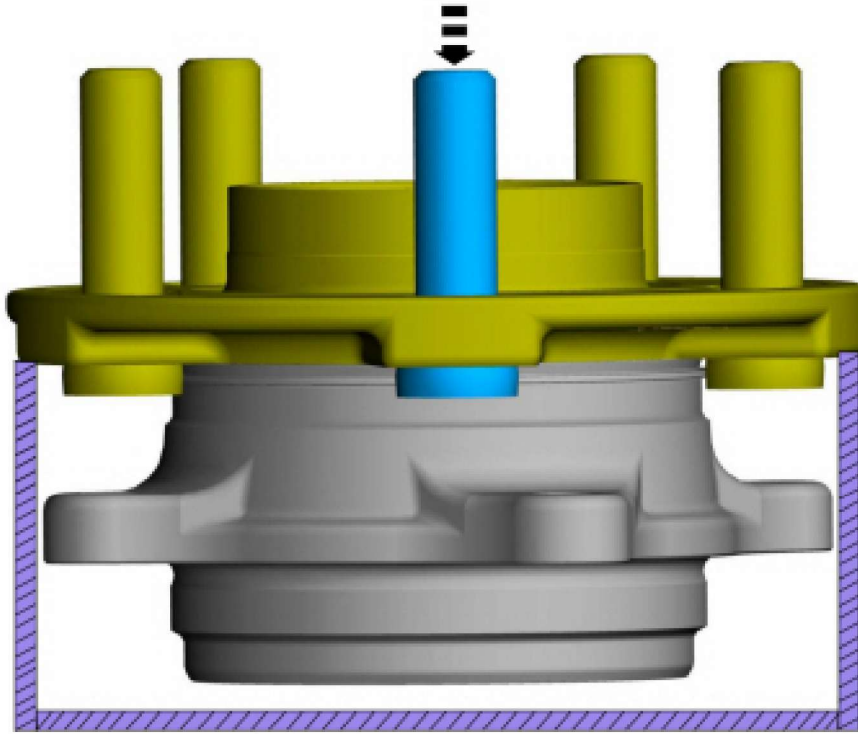

E408015



3. Inspect the wheel bearing and wheel hub for damage. Replace as necessary.

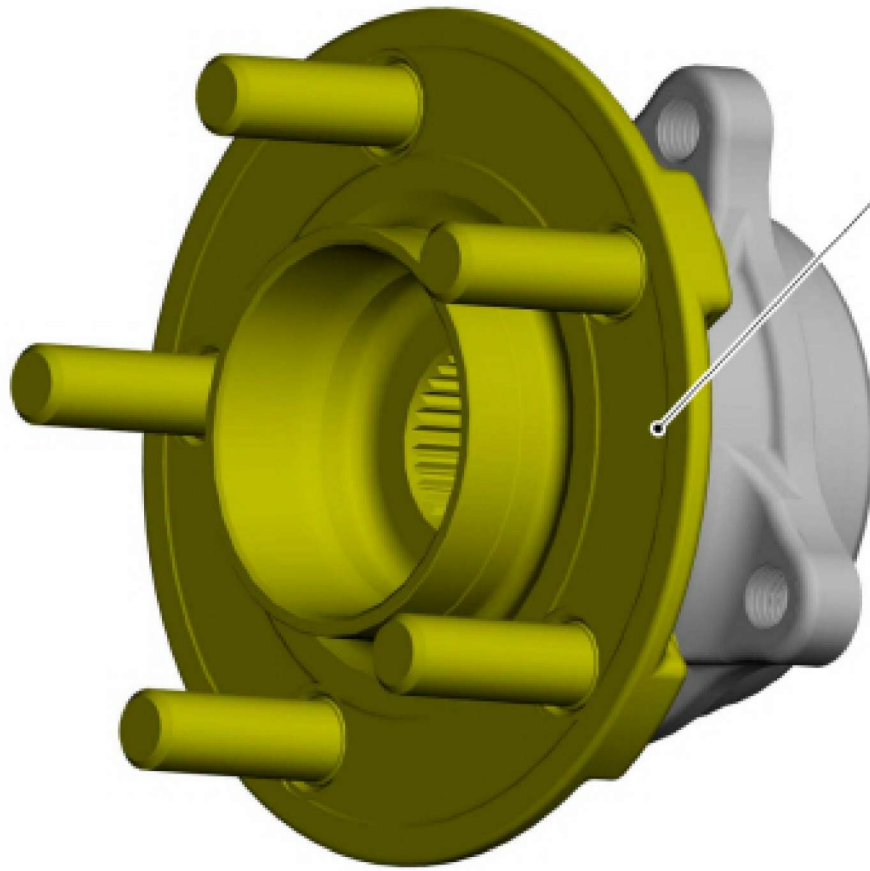

E408014



Installation

1. Press the wheel stud into the wheel bearing and wheel hub.
Use the General Equipment: Hydraulic Press

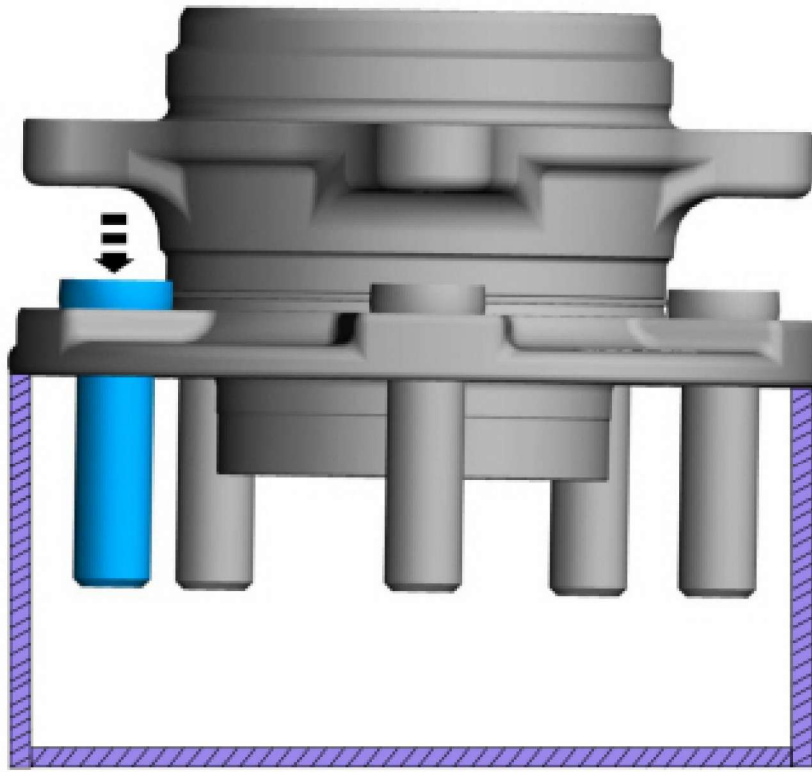

E408016



2. Install the wheel bearing and wheel hub.

Refer to: [Wheel Bearing and Wheel Hub](#) (204-02 Rear Suspension, Removal and Installation) .

Refer to: [Wheel Bearing and Wheel Hub - Dark Horse/GT](#) (204-02 Rear Suspension, Removal and Installation) .

© Copyright 2025, Ford Motor Company.
