

E261560

7. **NOTE:** *Only tighten the bolt finger tight at this stage.*

Position the lower arm vertical link and install the new lower arm vertical link lower bolt.

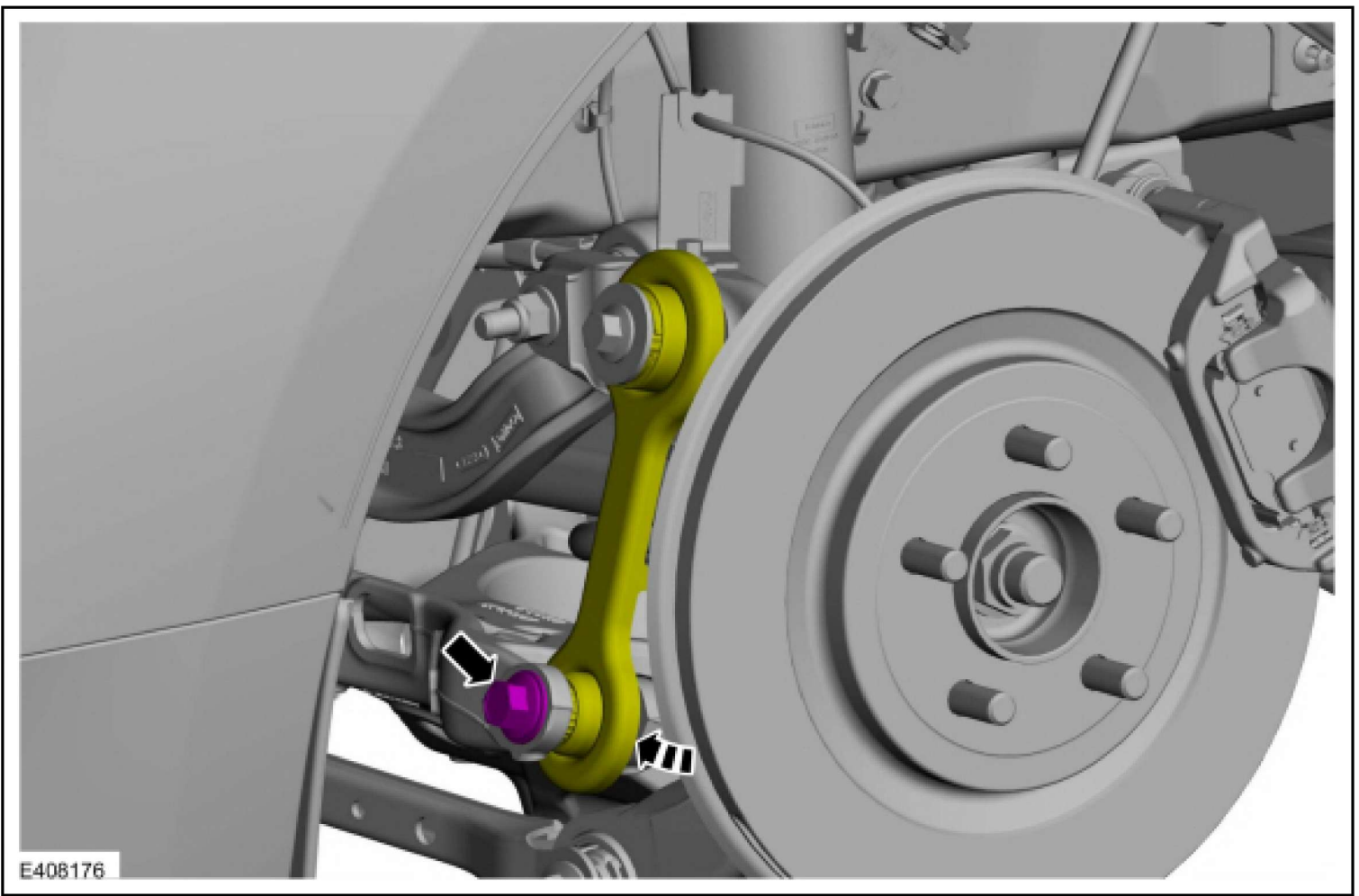

8. **NOTE:** *If equipped with dynamic suspension.*

Position the ride height sensor arm bracket and install the ride height sensor arm bracket bolt.  
*Torque : 177 lb.in (20 Nm)*

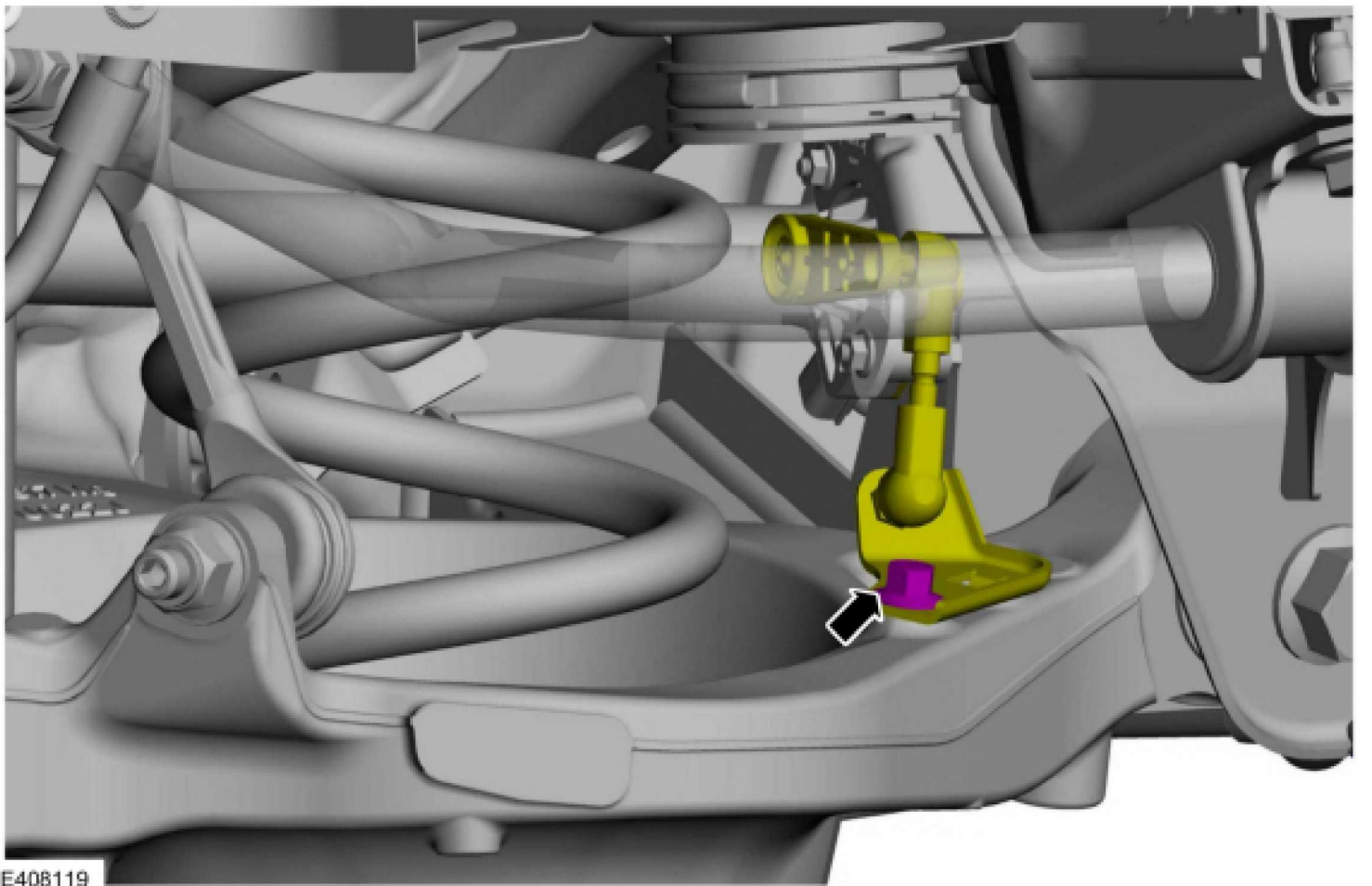

9. **NOTE:** *If equipped with dynamic suspension.*

Install the rear shock absorber and install the new rear shock absorber lower bolts.  
*Torque : 41 lb.ft (55 Nm)*

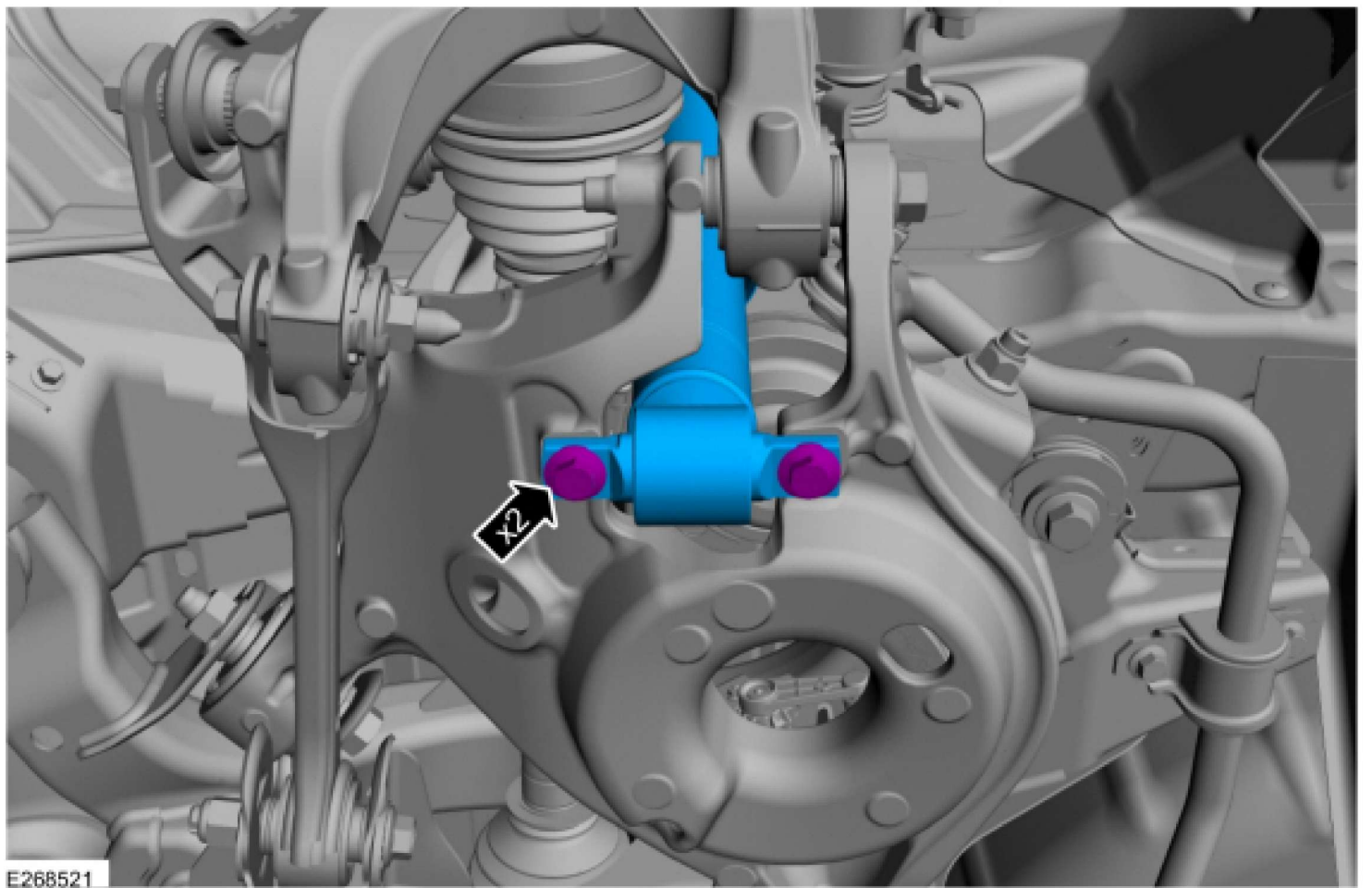

10. Install the new lower shock absorber bolts.  
*Torque : 41 lb.ft (55 Nm)*

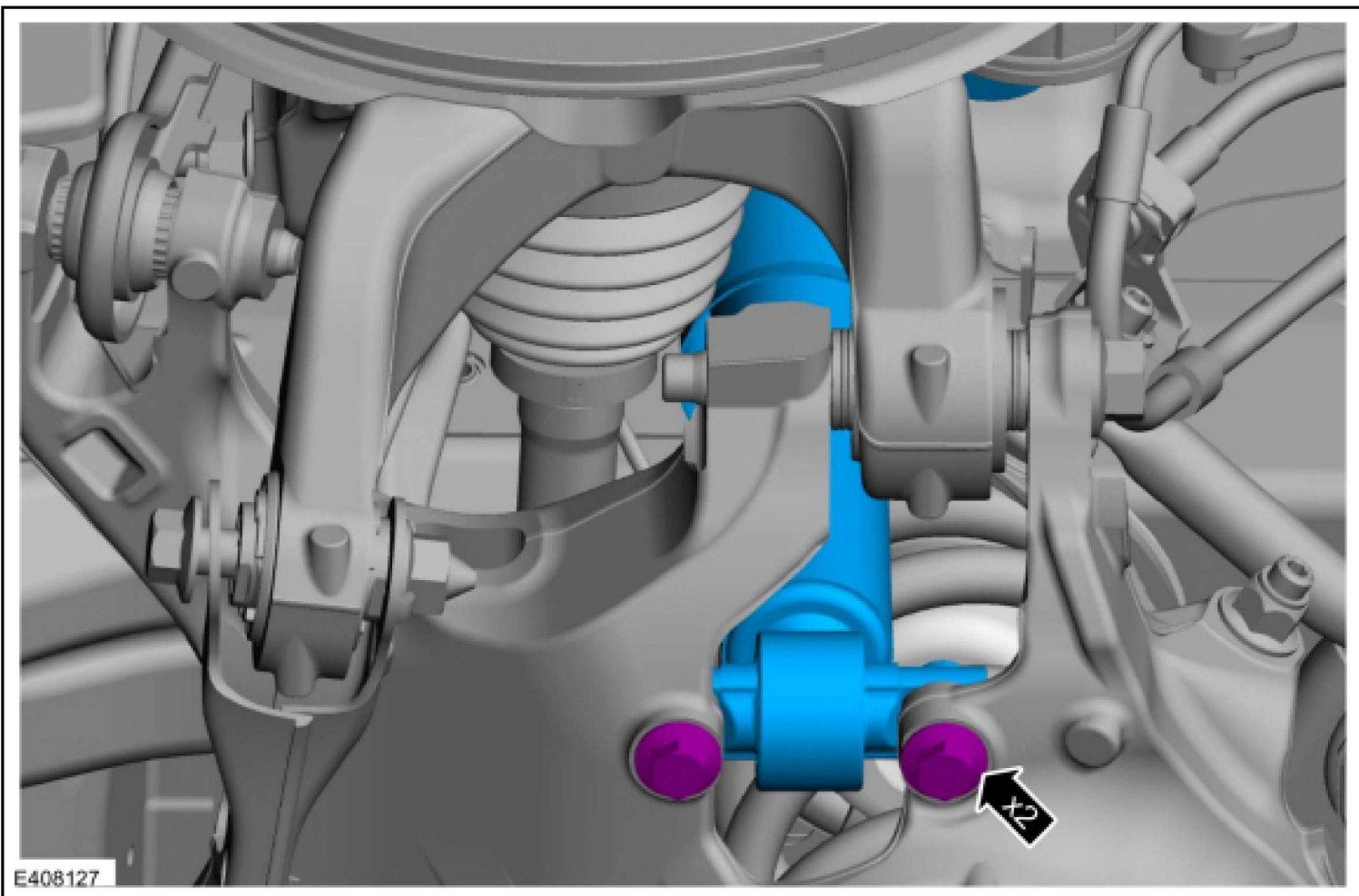

11. Support the suspension at curb height.  
Use the General Equipment: Vehicle/Axle Stands

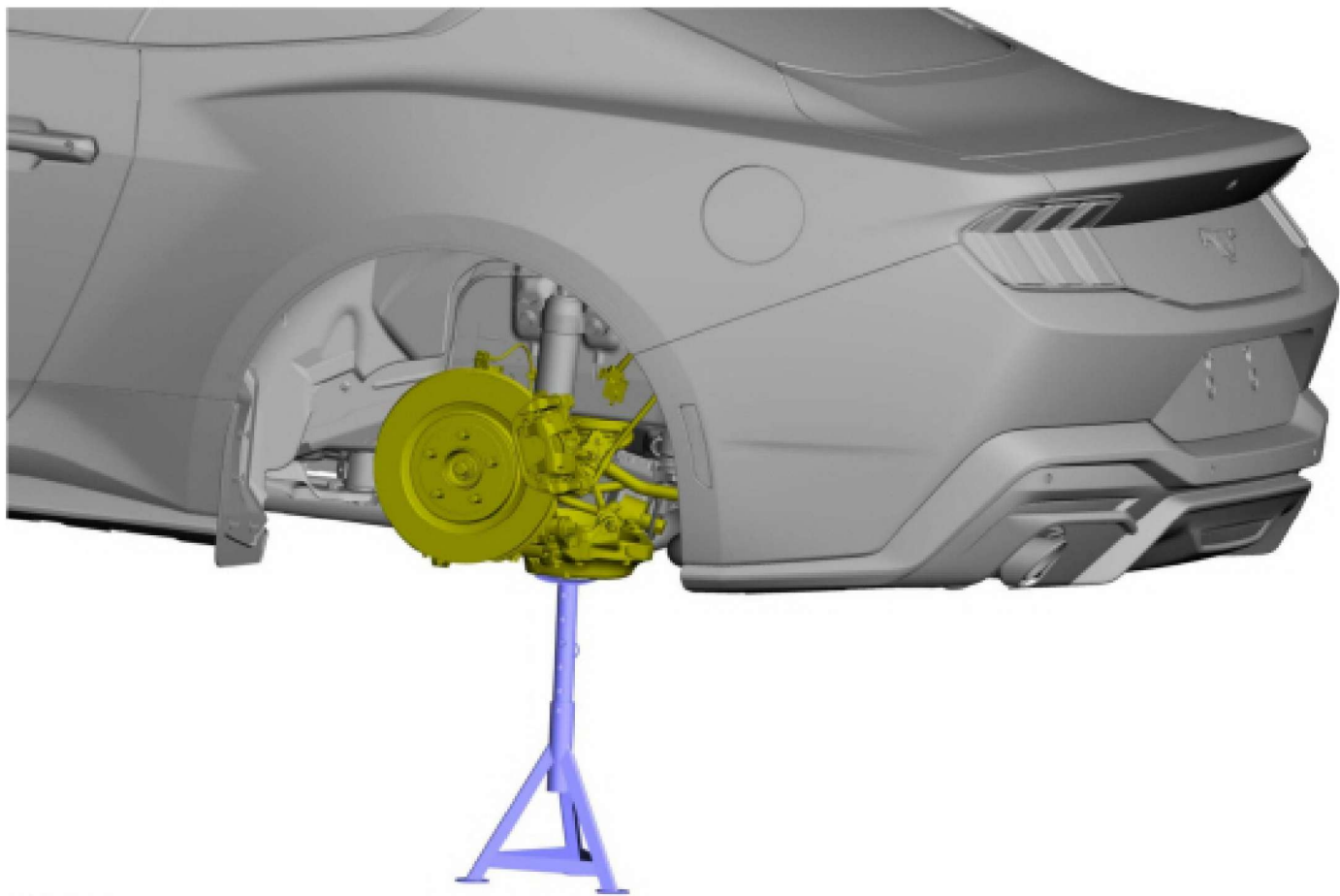

E408028



12. **NOTICE:** Tighten the suspension bushing fasteners with the suspension loaded or with the weight of the vehicle resting on the wheels and tires, otherwise incorrect clamp load and bushing damage may occur.

1. Tighten the rearward lower control arm-to-frame bolt.  
*Torque* : 184 lb.ft (250 Nm)
2. Tighten the lower control arm-to-wheel knuckle bolt.  
*Torque* : 203 lb.ft (275 Nm)

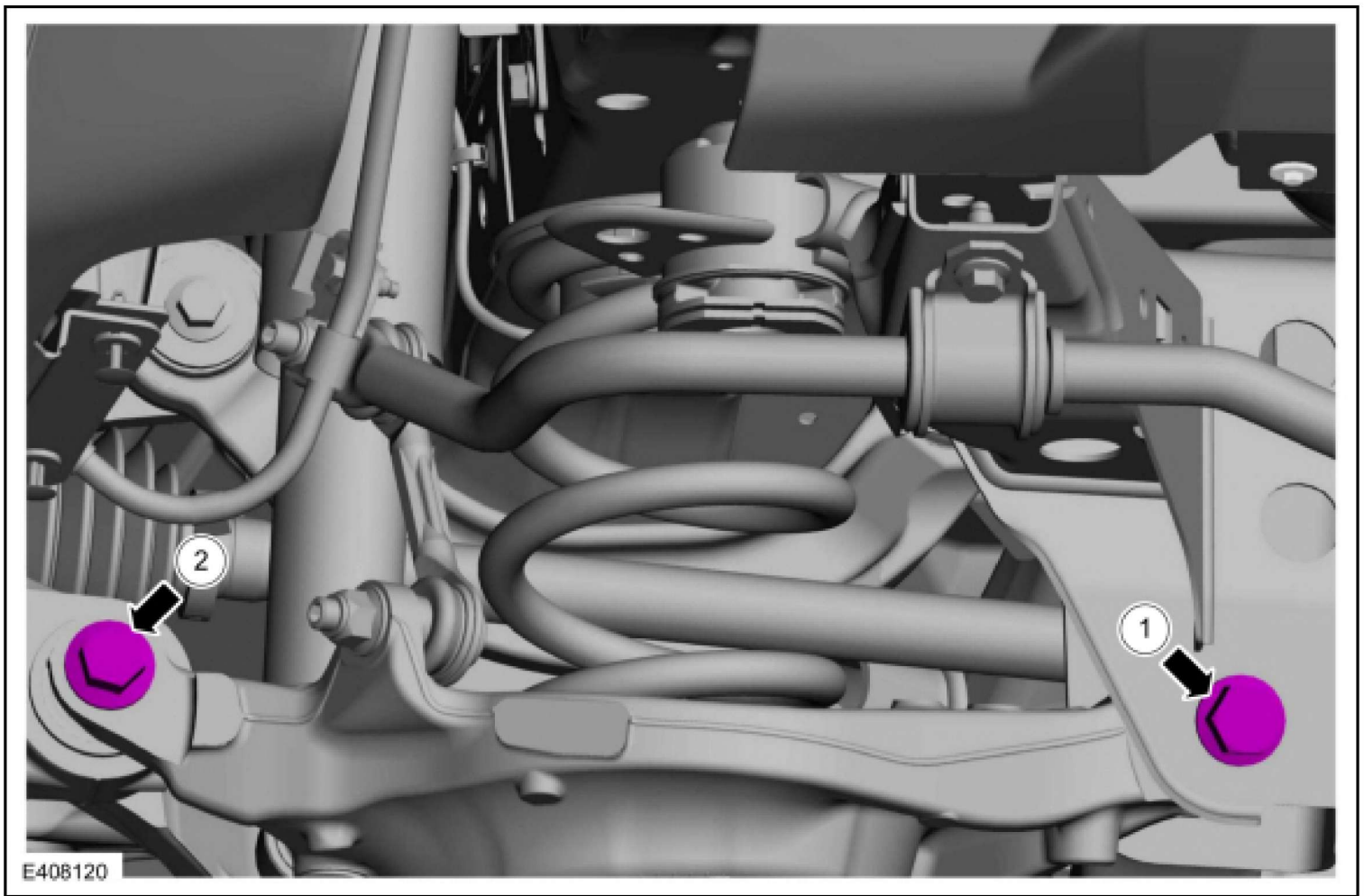

13. **NOTICE:** Tighten the suspension bushing fasteners with the suspension loaded or with the weight of the vehicle resting on the wheels and tires, otherwise incorrect clamp load and bushing damage may occur.

Tighten the forward lower control arm-to-frame bolt.  
*Torque* : 166 lb.ft (225 Nm)

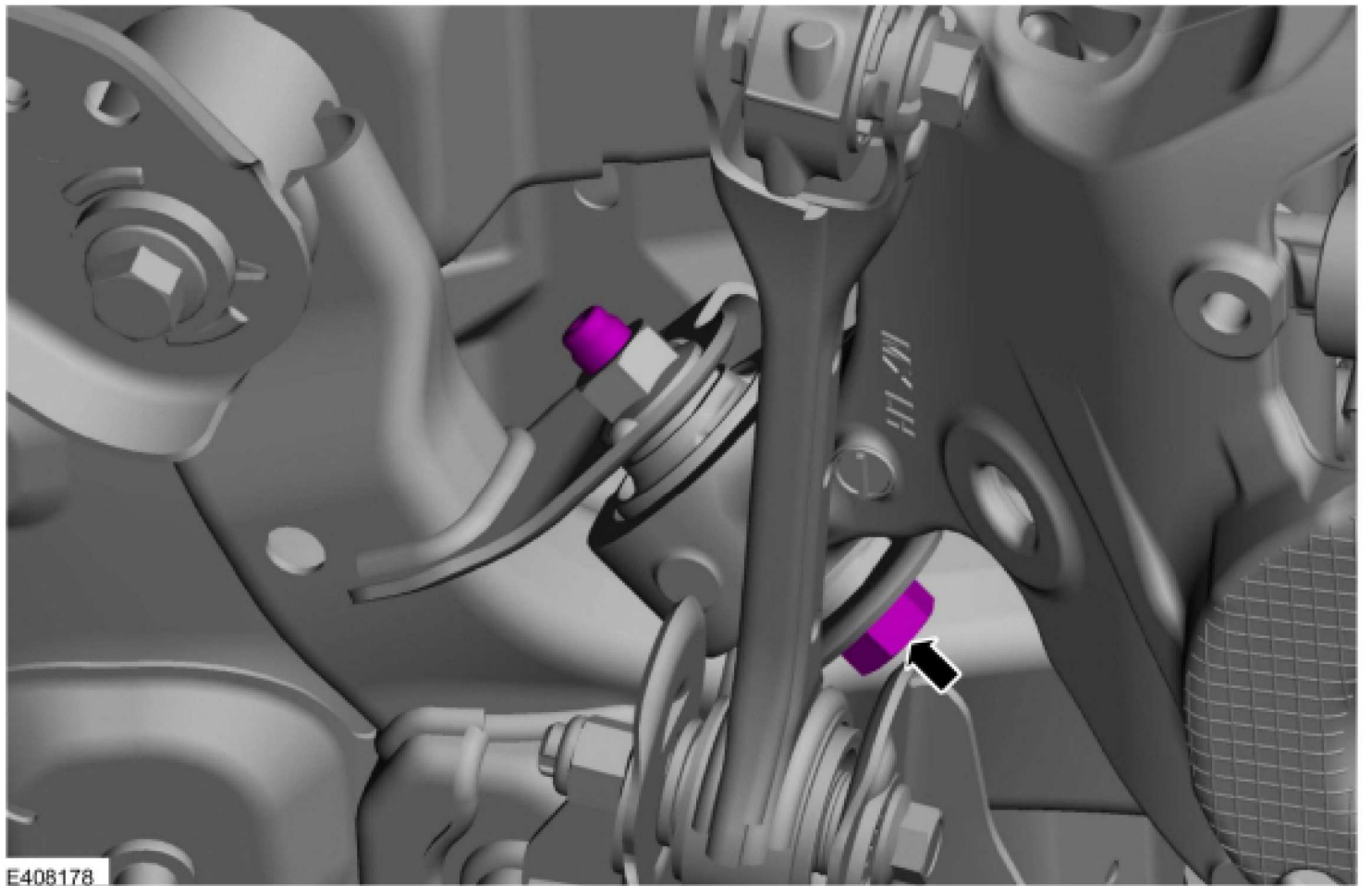

14. **NOTICE:** Tighten the suspension bushing fasteners with the suspension loaded or with the weight of the vehicle resting on the wheels and tires, otherwise incorrect clamp load and bushing damage may occur.

Tighten lower arm vertical link lower bolt.  
*Torque* : 129 lb.ft (175 Nm)

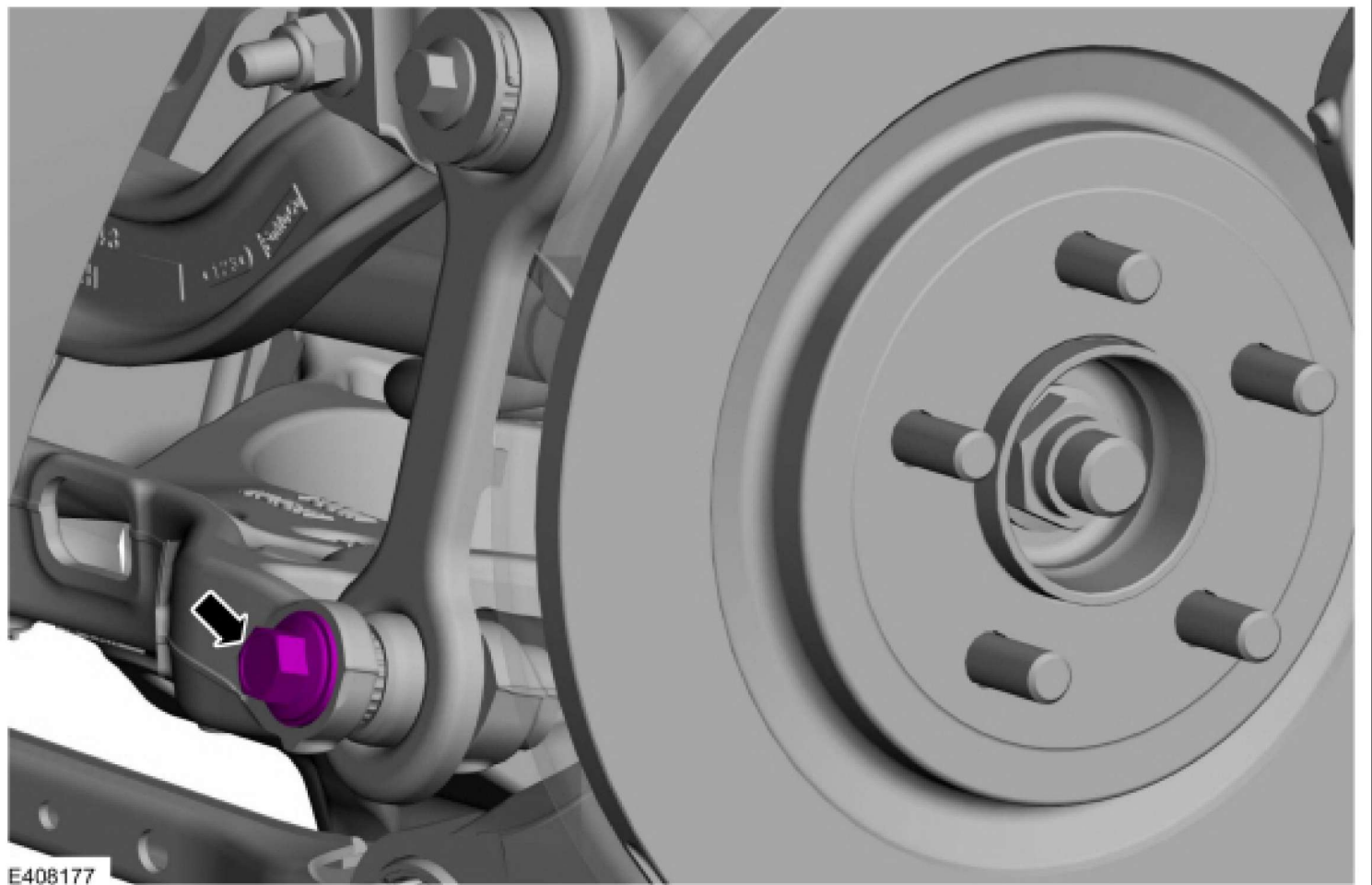

15. **NOTICE:** Tighten the suspension fasteners with the weight of the vehicle on the wheels and tires or use a suitable jack to raise the suspension to curb height or damage to the bushings may occur.

Tighten the new stabilizer bar link nut.  
*Torque* : 85 lb.ft (115 Nm)

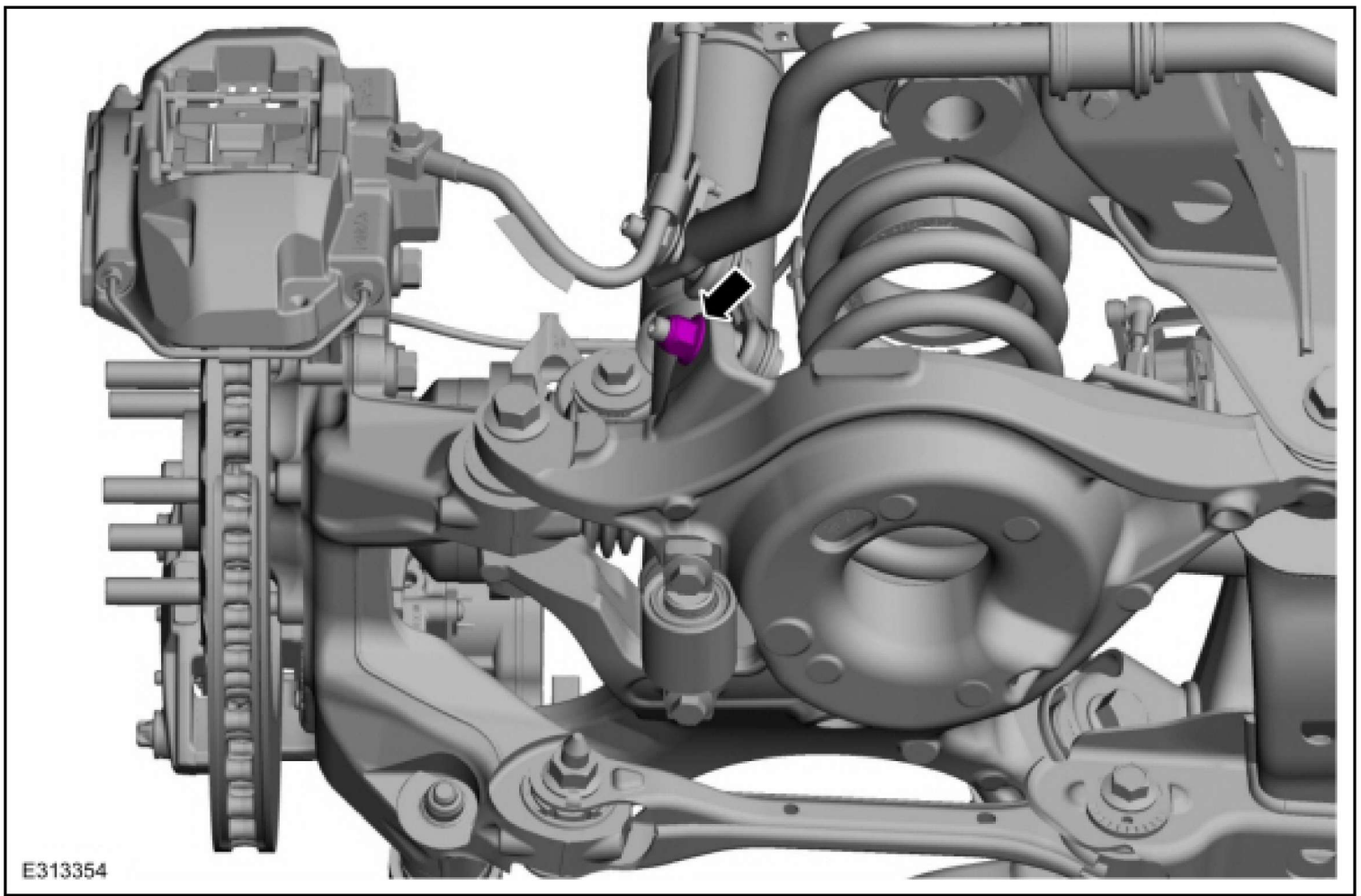

16. Install the wheel and tire.

Refer to: [Wheel and Tire](#) (204-04A Wheels and Tires, Removal and Installation) .

17. Check and if necessary, adjust rear camber.

Refer to: [Rear Camber Adjustment](#) (204-00 Suspension System - General Information, General Procedures) .

18. If equipped with dynamic suspension, calibrate the suspension system. Connect the scan tool and carry out the Ride Height Calibration routine. Follow the scan tool directions.

© Copyright 2025, Ford Motor Company.

---



## Lower Arm - Dark Horse/GT



### Special Tool(s) / General Equipment

Vehicle/Axle Stands
------------------------

### Removal

**NOTICE:** Suspension fasteners are critical parts that affect the performance of vital components and systems. Failure of these fasteners may result in major service expense. Use the same or equivalent parts if replacement is necessary. Do not use a replacement part of lesser quality or substitute design. Tighten fasteners as specified.

1. Remove the wheel and tire.  
Refer to: [Wheel and Tire](#) (204-04A Wheels and Tires, Removal and Installation) .
2. Raise the suspension approximately 20mm from rebound condition.  
Use the General Equipment: Vehicle/Axle Stands

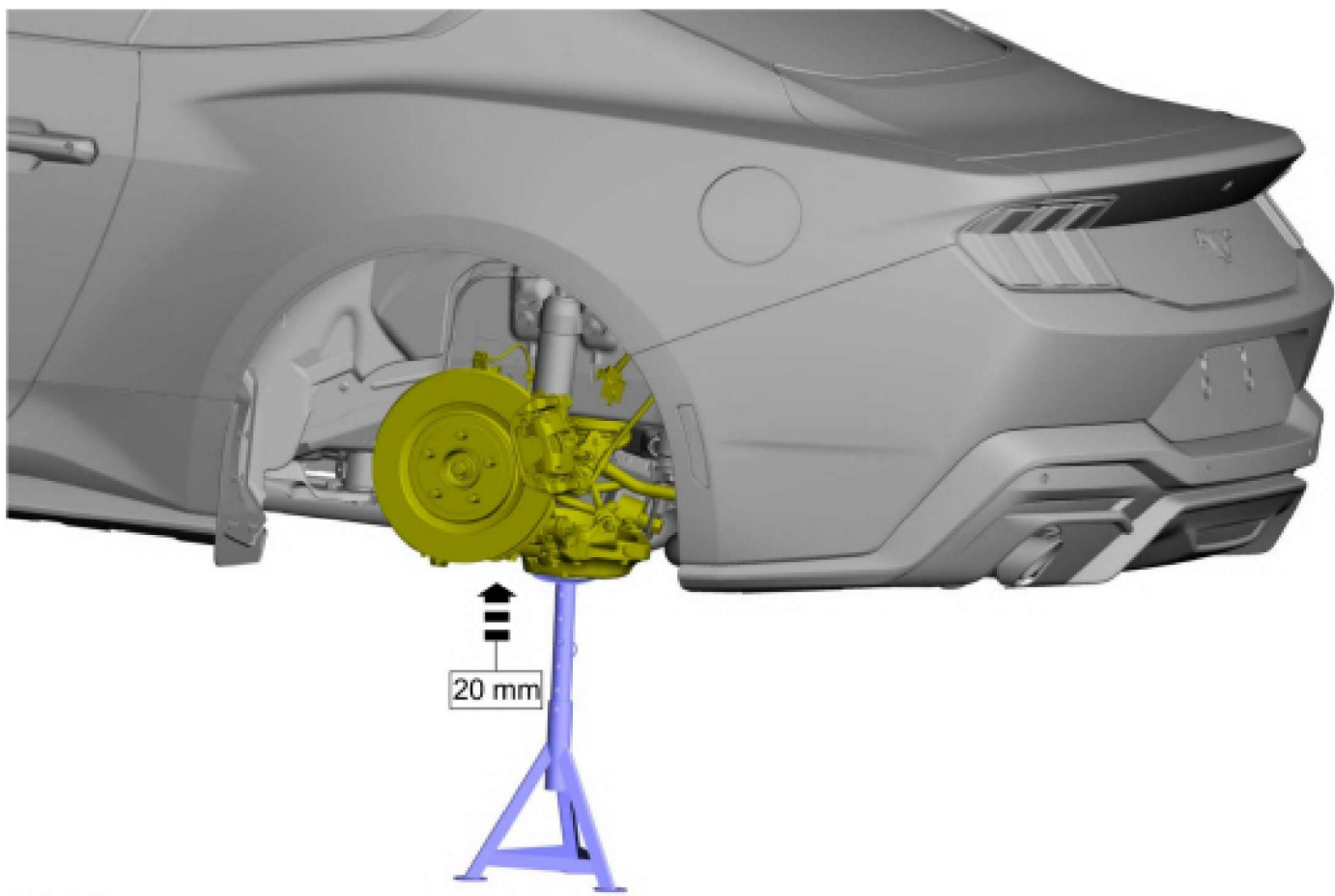

E408129

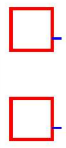

3. Remove and discard the rear shock absorber lower bolts.

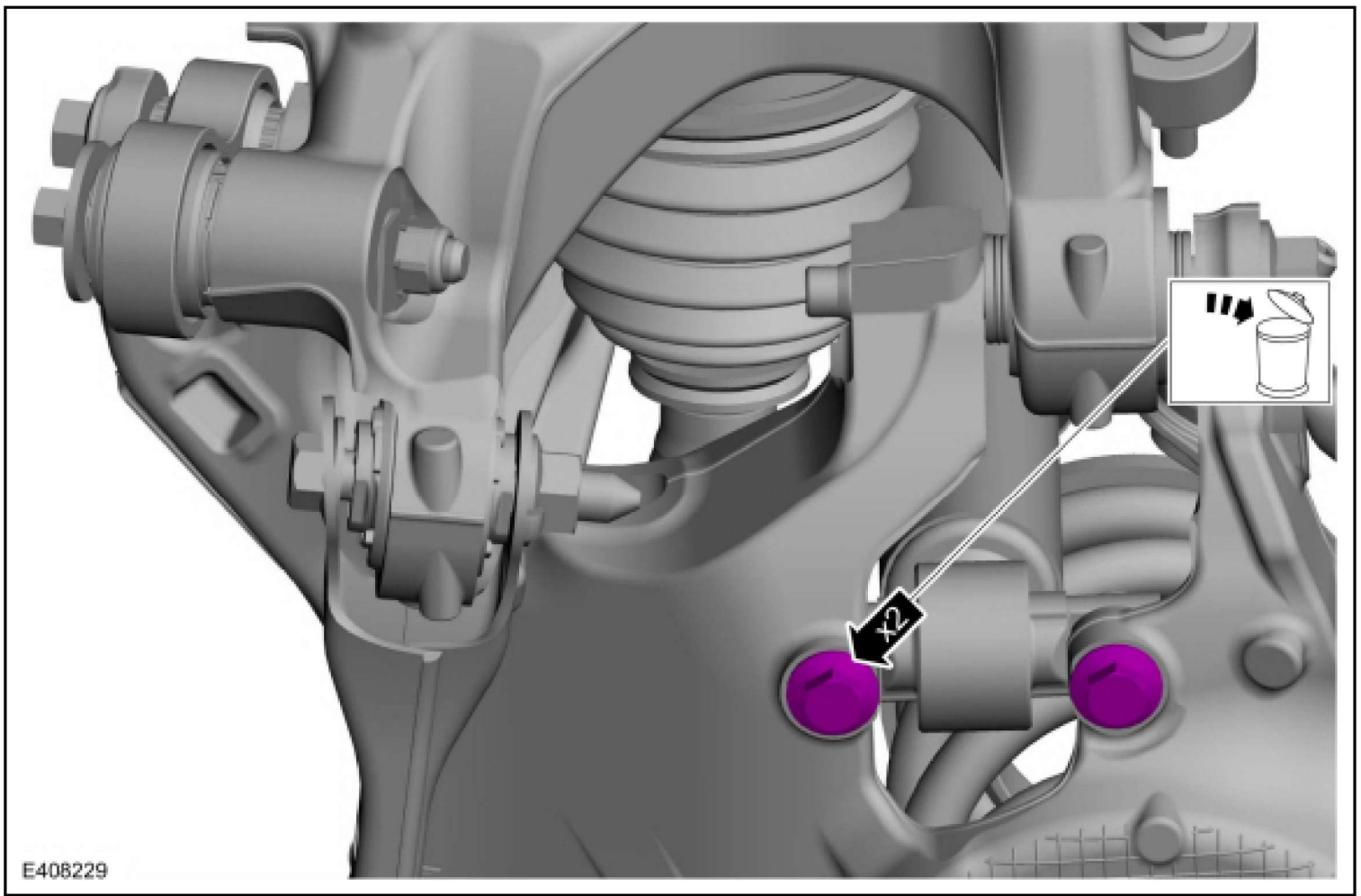

4. **NOTE:** *If equipped with dynamic suspension.*

Remove and discard the rear shock absorber lower bolts.



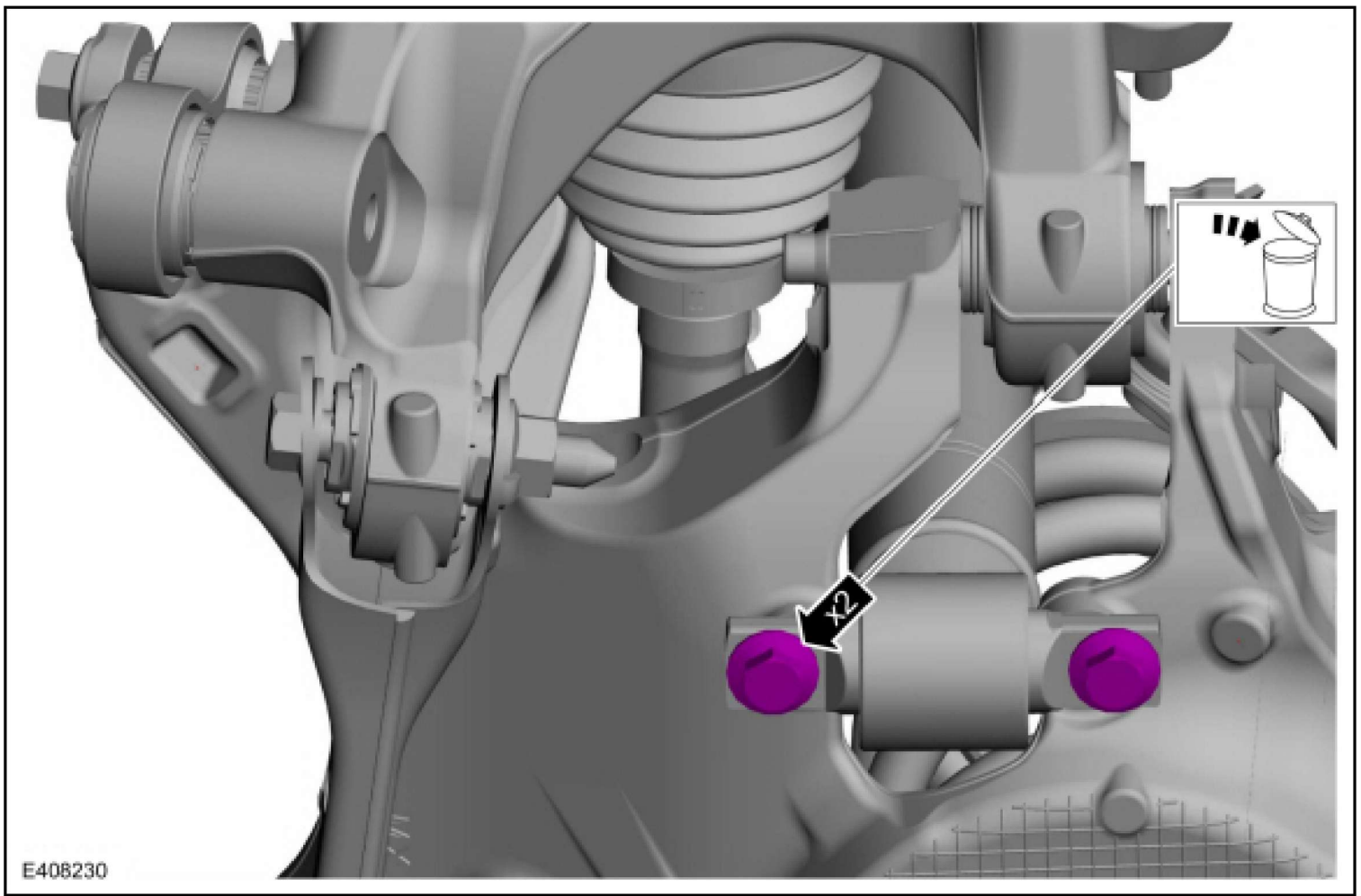

5. **NOTE:** *If equipped with dynamic suspension.*

Remove the rear height sensor arm bracket bolt and position the rear height sensor arm bracket aside.

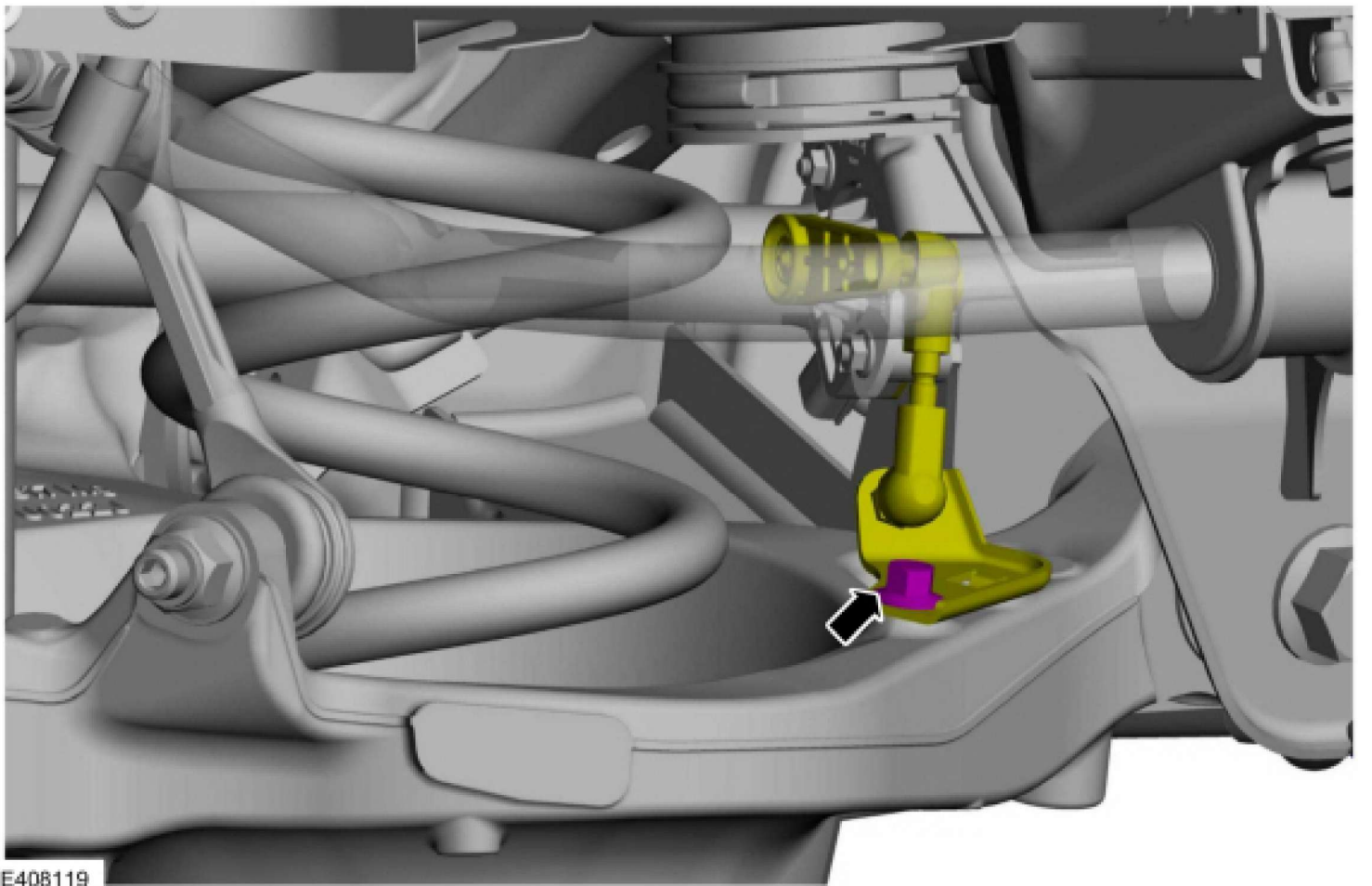

- Remove and discard the lower arm vertical link upper bolt and position aside the lower arm vertical link.
- Remove and discard the toe link-to-knuckle bolt and position aside.

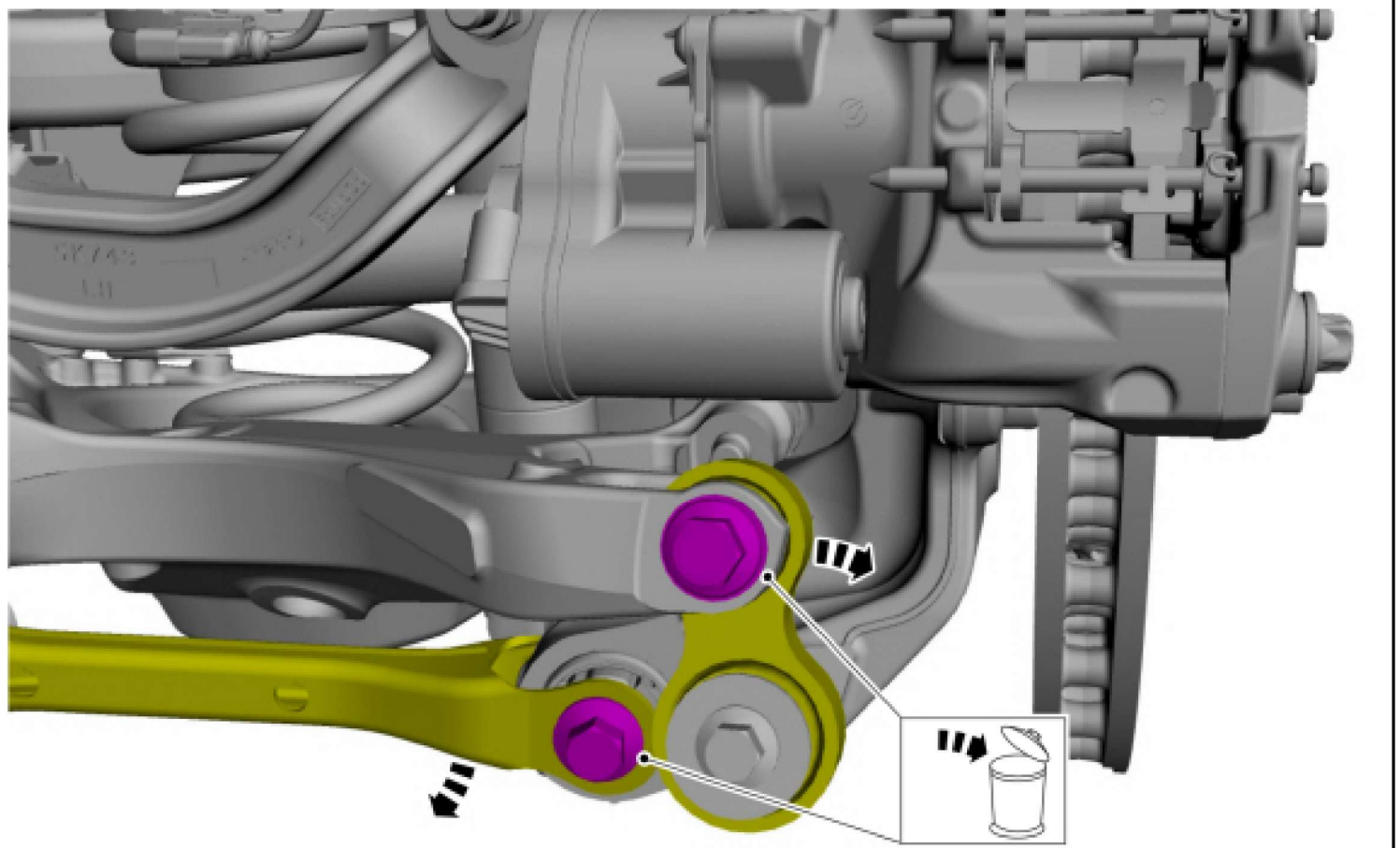

E313348

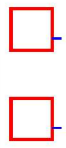

7. **NOTE:** *Make sure that the knuckle is supported with suitable retaining straps.*

1. Remove and discard the rear stabilizer bar link lower nut and position the rear stabilizer bar link aside.
2. Remove and discard lower arm-to-wheel knuckle bolt and separate the wheel knuckle from the lower arm.



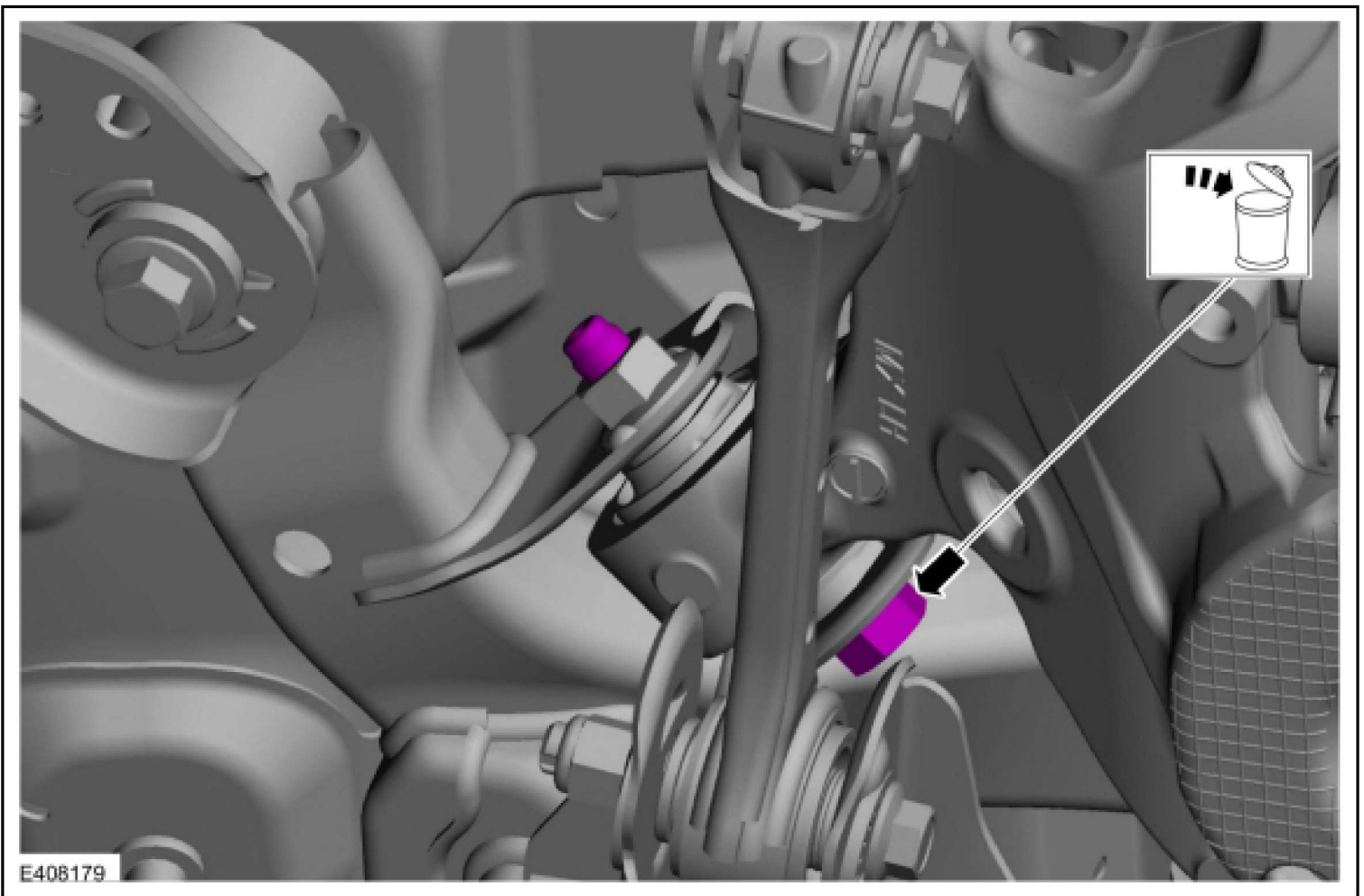

10. **NOTICE:** Take extra care when handling a compressed spring. Failure to follow this instruction may result in personal injury.

**NOTE:** Do not allow the rear spring to fall.

1. Lower the suspension to release the spring compression.
2. Remove the spring by lowering the lower arm and position aside.
3. Remove and discard the lower arm-to-frame rearward bolt and remove the lower arm.  
Use the General Equipment: Vehicle/Axle Stands

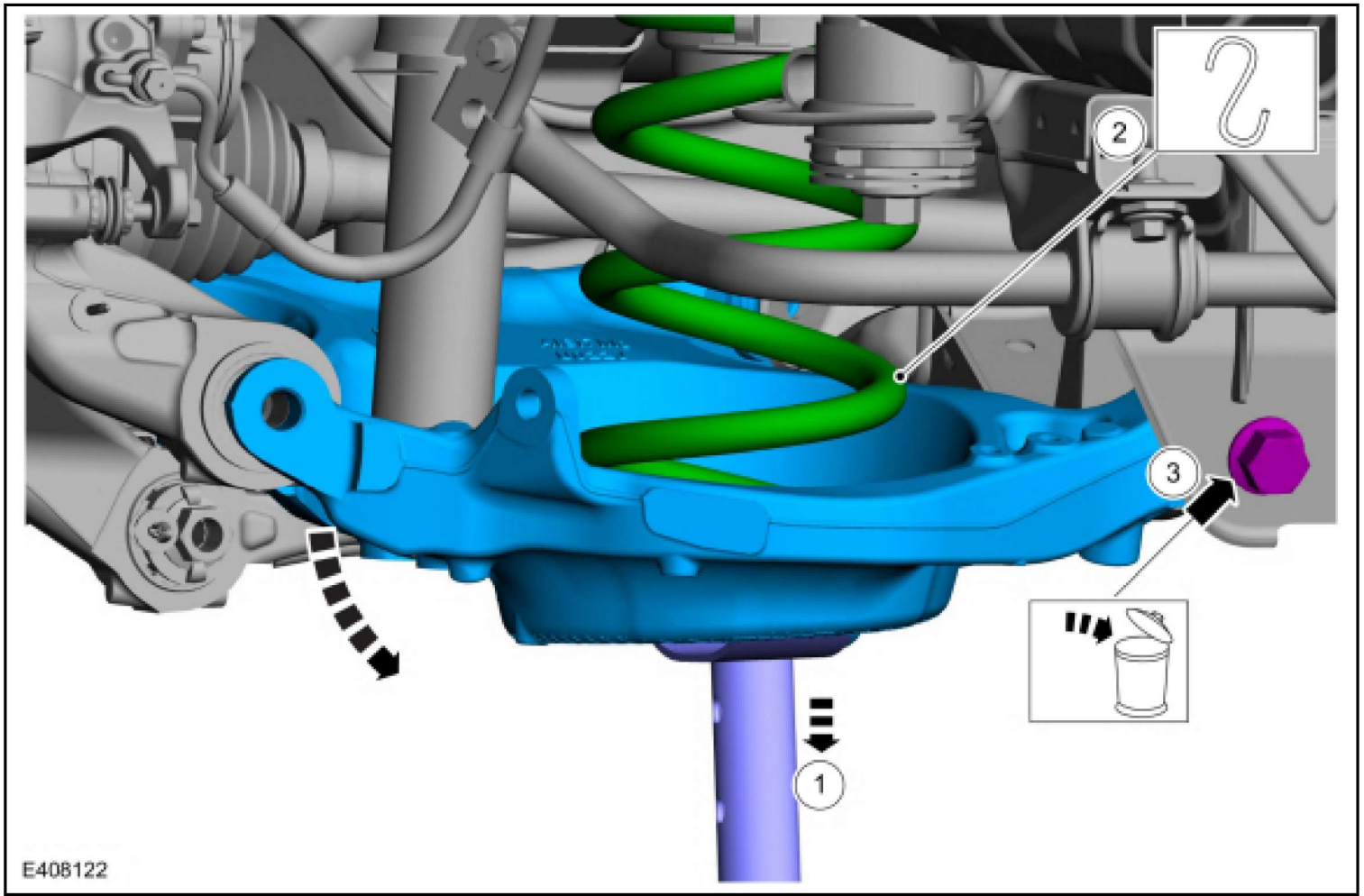

**Installation**

1. Inspect the lower coil spring seat. Make sure it is properly aligned in the lower control arm.

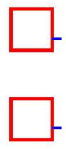

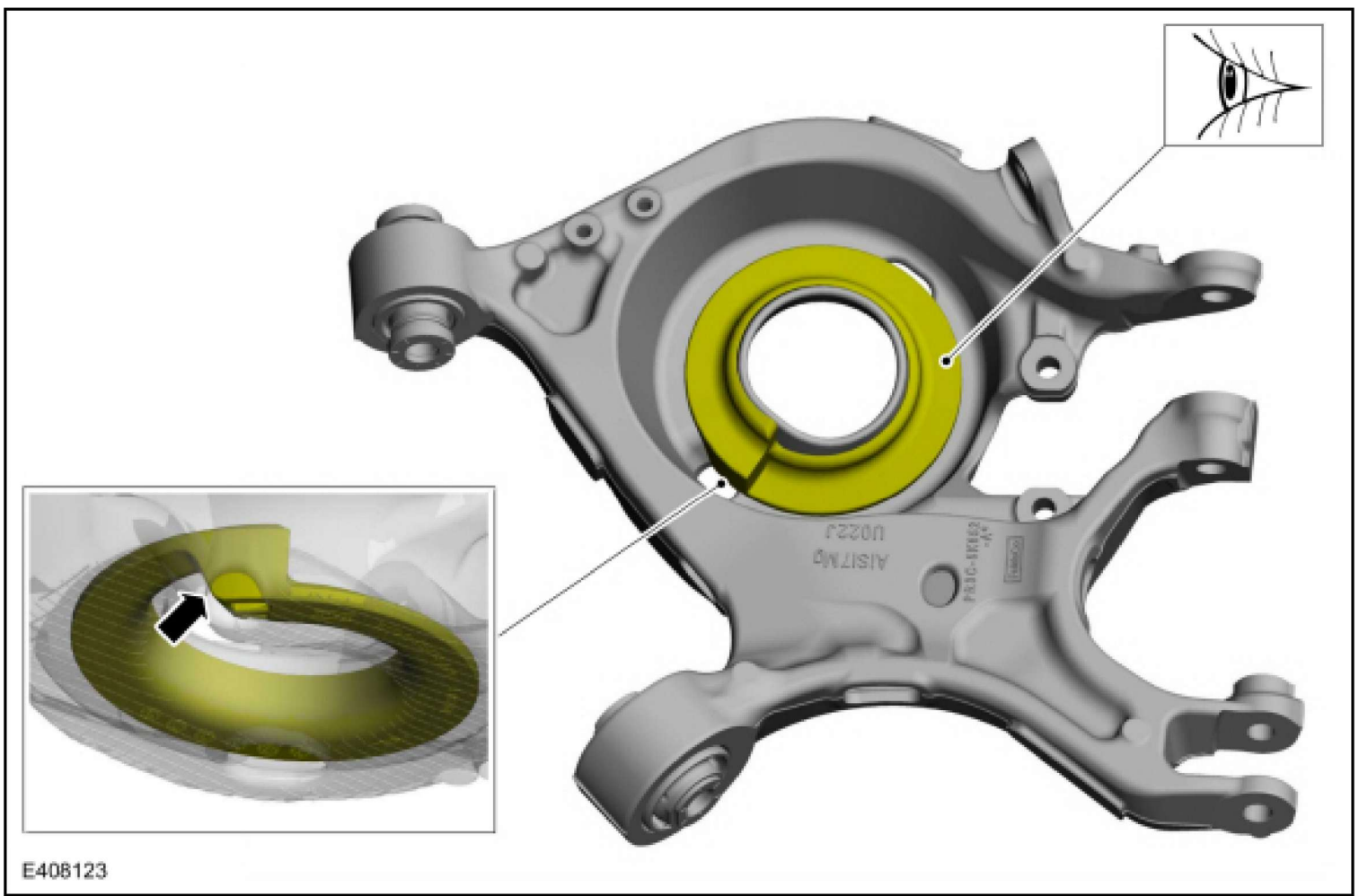

2. **NOTE:** *Hold spring in place while installing lower arm.*

1. **NOTE:** *Before tightening the lower arm bolt, use a jackstand to raise the rear suspension to ride height.*

Position the jackstand under the lower arm and raise the lower arm into position.  
Use the General Equipment: Vehicle/Axle Stands

2. **NOTE:** *Make sure the upper spring seat is properly positioned on the upper spring mount.*

Install the spring into the upper and lower spring seat.

3. **NOTE:** *Only tighten the bolt finger tight at this stage.*

Install the new lower arm-to-frame rearward bolt.

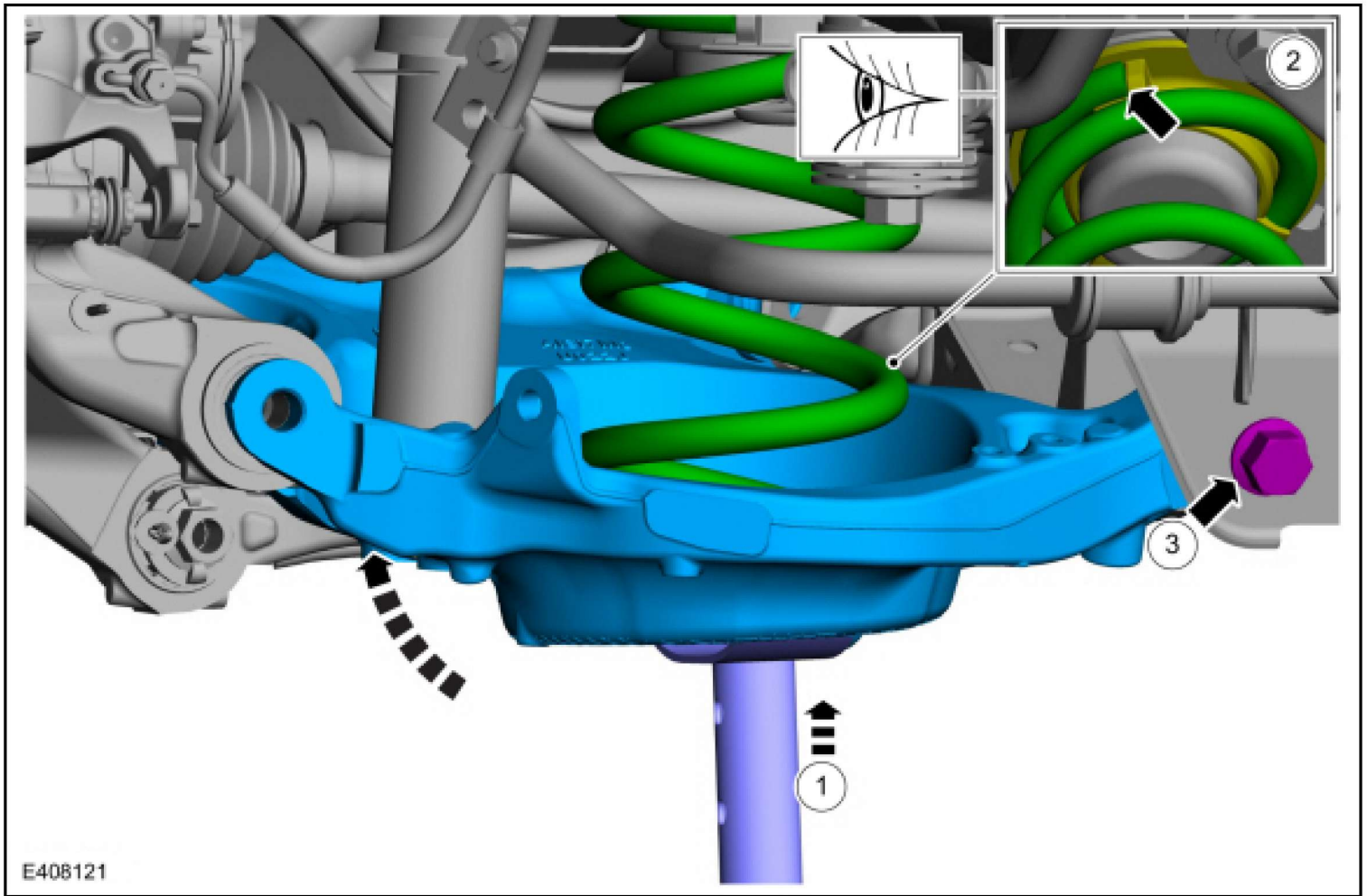

3. Make sure that the coil spring is properly positioned in the lower coil spring seat.



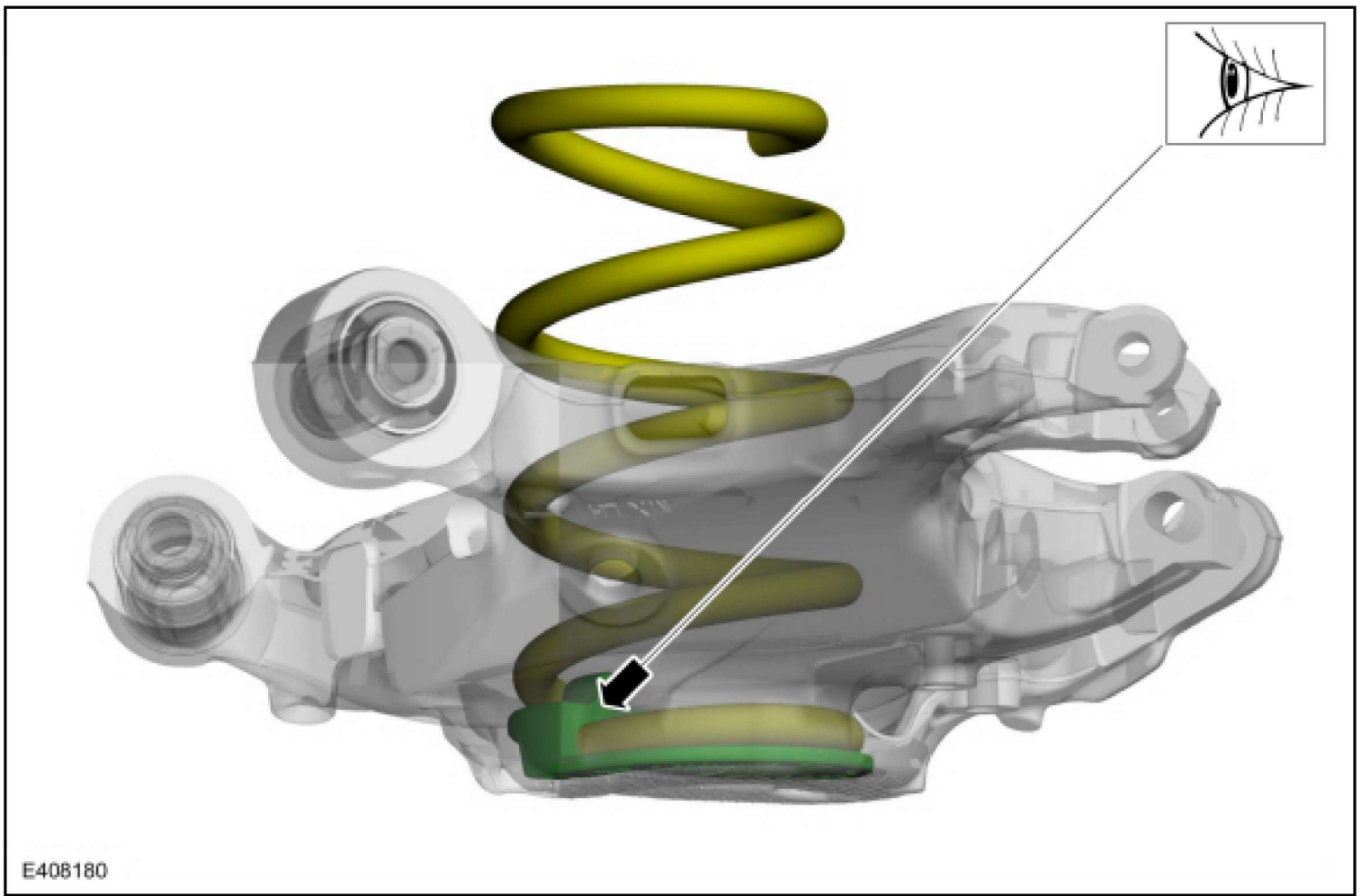

4. **NOTE:** *Only tighten the bolt finger tight at this stage.*

Install the new forward lower control arm-to-frame bolt.

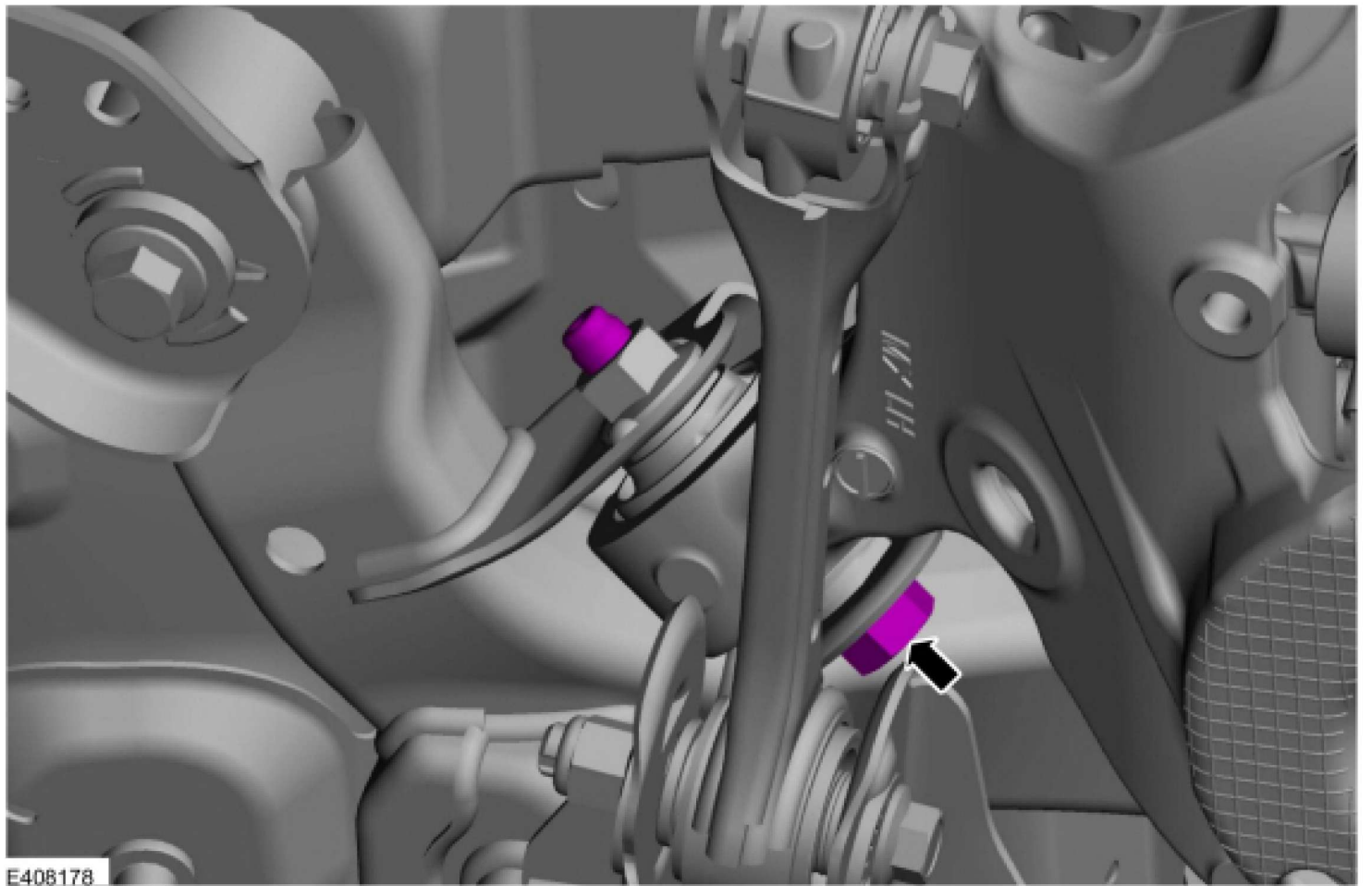

5. **NOTE:** *The muffler and tailpipe were removed for clearance for the lower control arm rearward bolts.*

Install the muffler and tailpipe.

Refer to: [Muffler and Tailpipe](#) (309-00B Exhaust System - 5.0L 32V Ti-VCT (359kW/486PS) (WU)/5.0L Ti-VCT V8 (331kW/450PS) (MF), Removal and Installation) .

6. **NOTE:** *Only tighten the bolt finger tight at this stage.*

1. Position the wheel knuckle and install the lower arm-to-wheel knuckle bolt.
2. Position the stabilizer bar link and install the new stabilizer bar link lower nut.

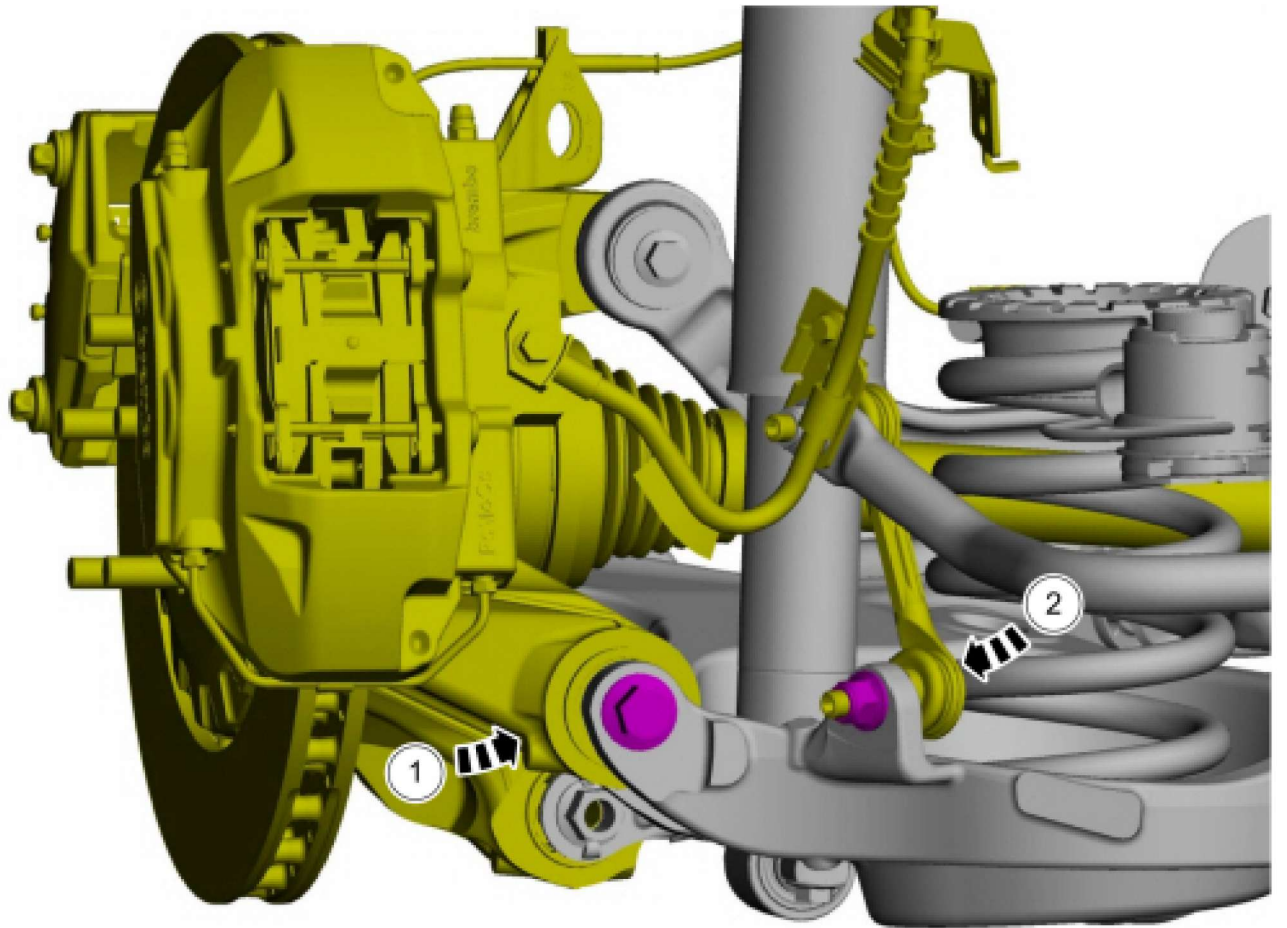

E313350

7. **NOTE:** *Only tighten the bolt finger tight at this stage.*

- Position the lower arm vertical link and install the new lower arm vertical link upper bolt.
- Position the toe link and install the new toe link-to-knuckle bolt.

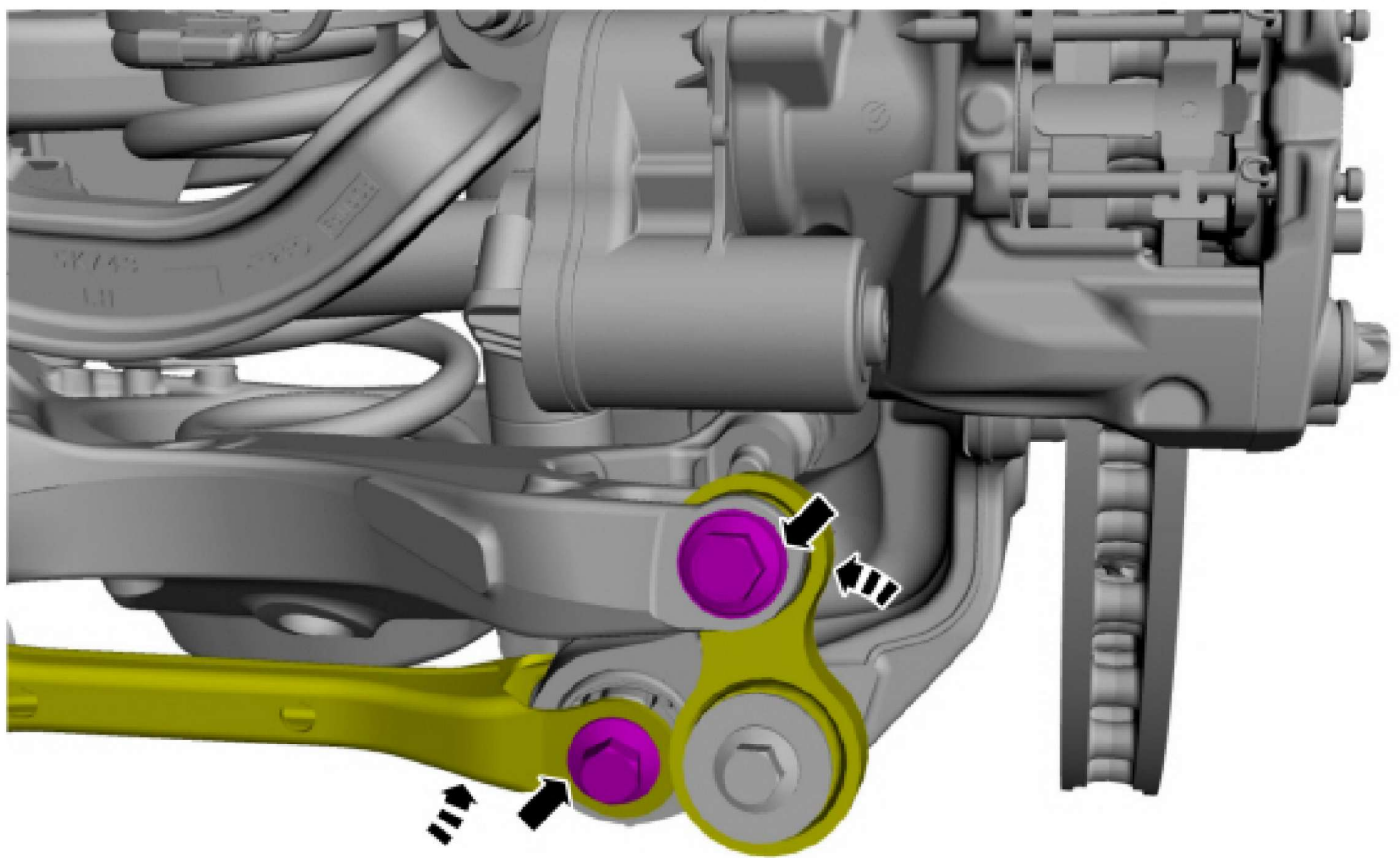

E313351



8. **NOTE:** *If equipped with dynamic suspension.*

Position the ride height sensor arm bracket and install the ride height sensor arm bracket bolt.  
*Torque : 177 lb.in (20 Nm)*

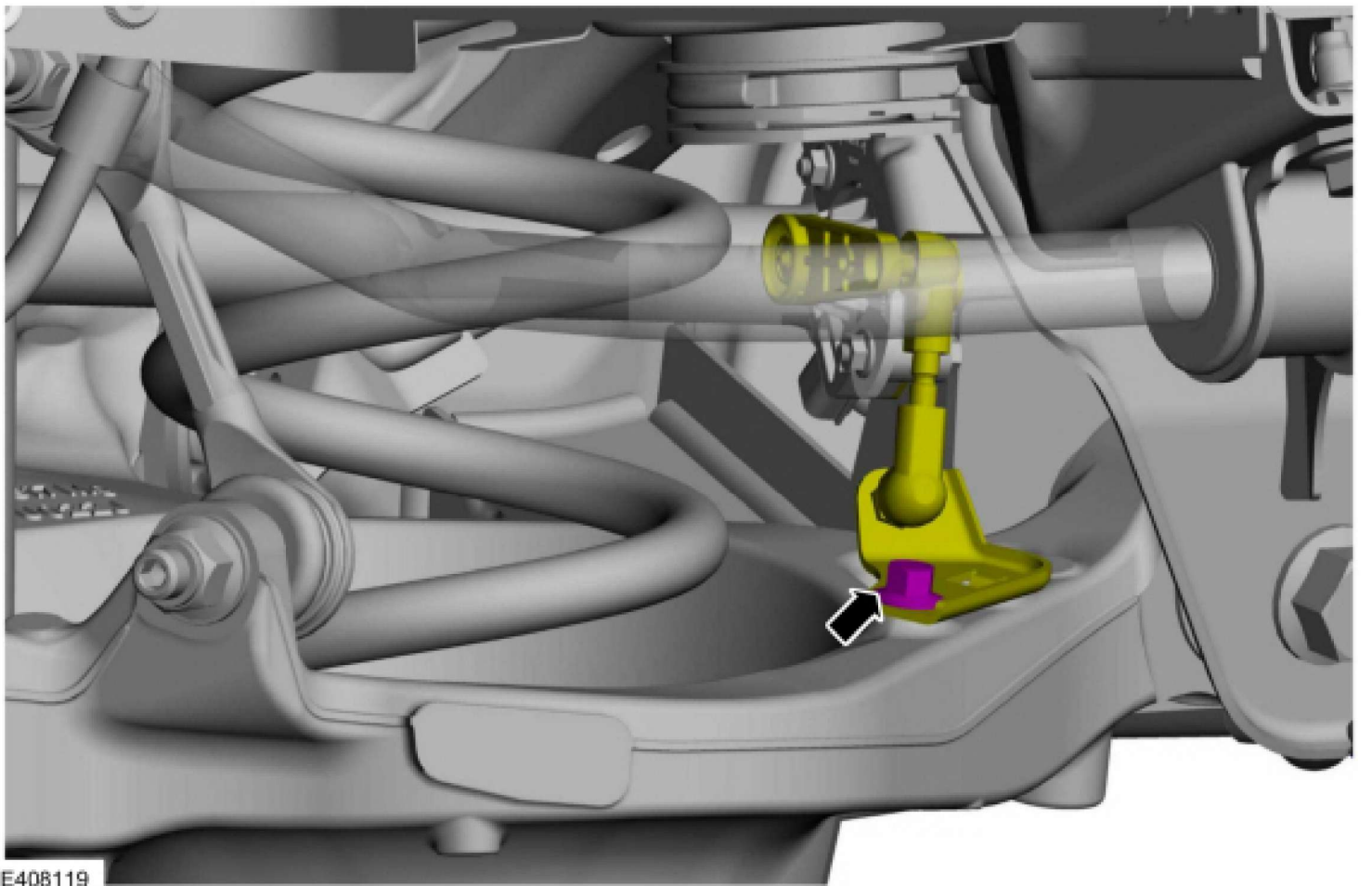

9. **NOTE:** *If equipped with dynamic suspension.*

Install the rear shock absorber and install the new rear shock absorber lower bolts.  
*Torque : 41 lb.ft (55 Nm)*

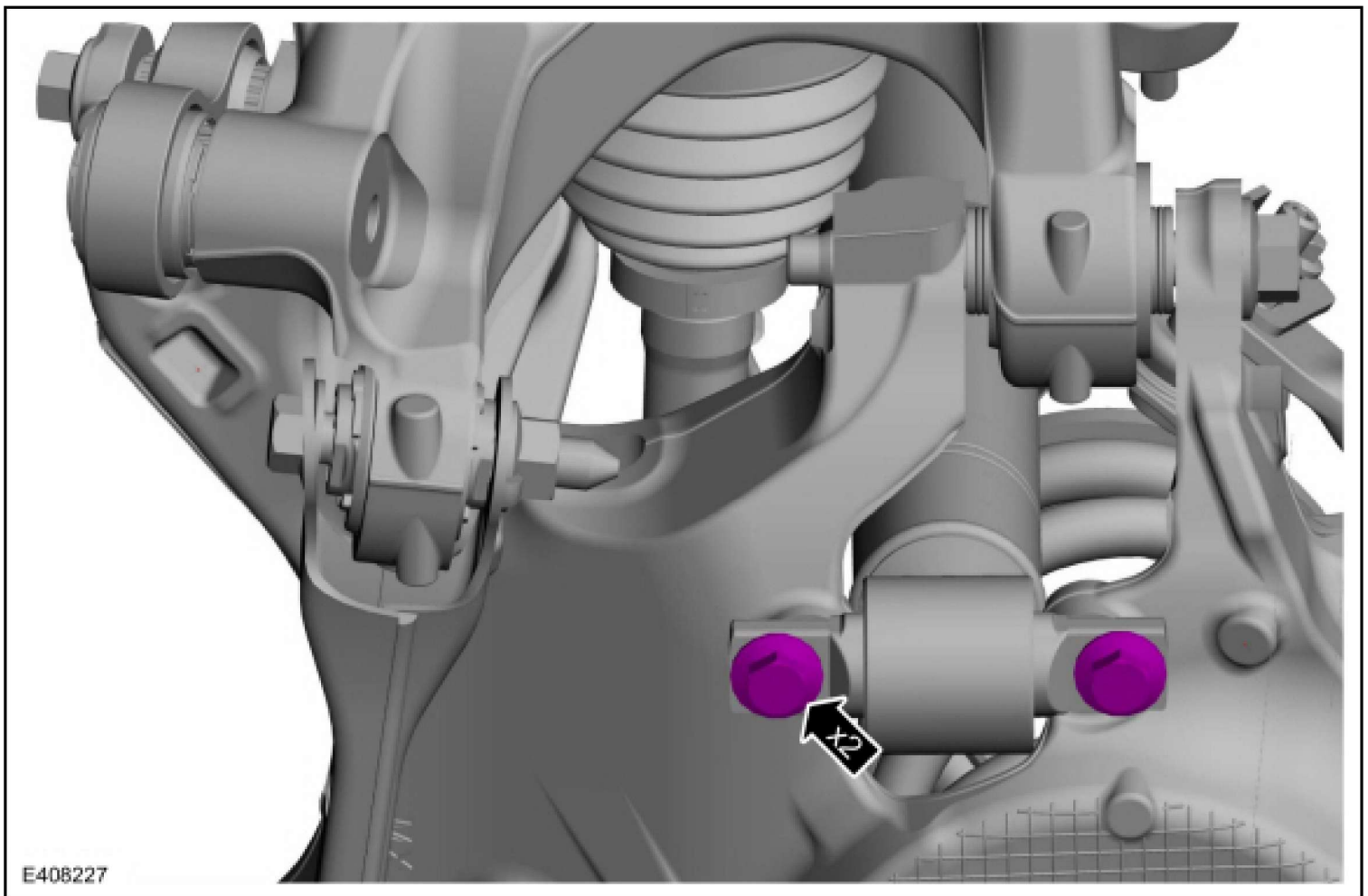

10. Install the new lower shock absorber bolts.  
*Torque : 41 lb.ft (55 Nm)*

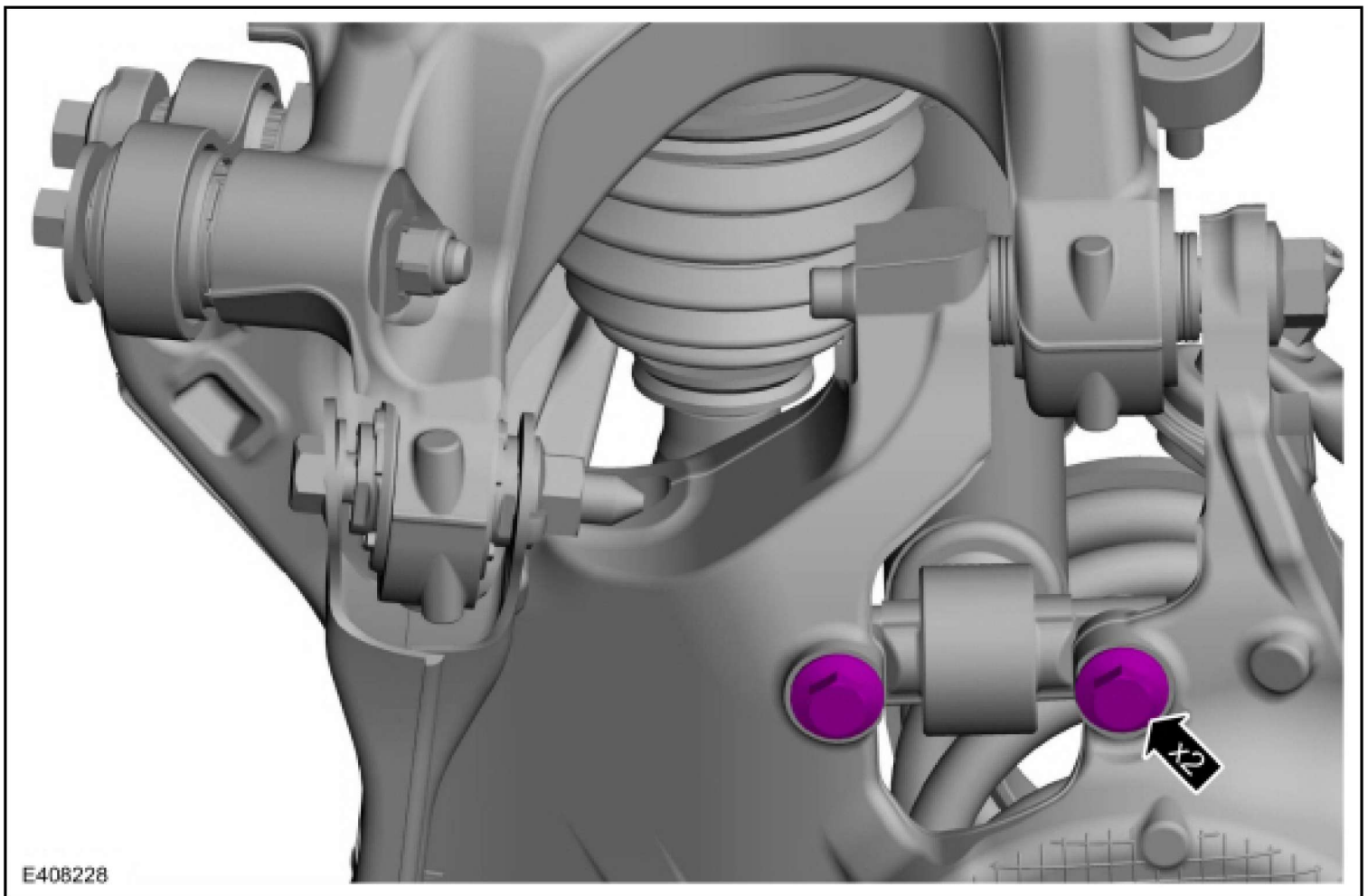

11. Support the suspension at curb height.  
Use the General Equipment: Vehicle/Axle Stands

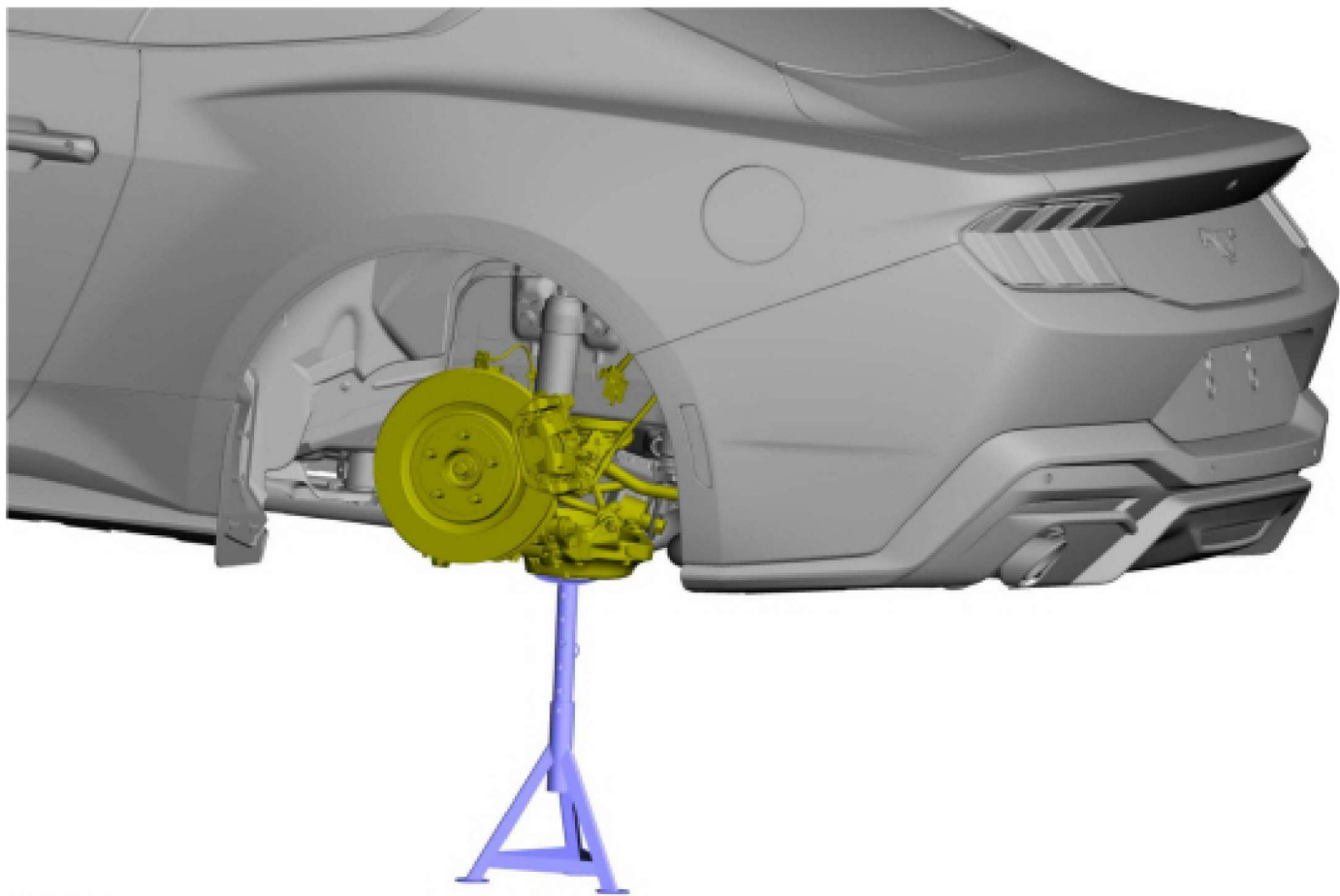

E408028



12. **NOTICE:** Tighten the suspension bushing fasteners with the suspension loaded or with the weight of the vehicle resting on the wheels and tires, otherwise incorrect clamp load and bushing damage may occur.

1. Tighten the rearward lower control arm-to-frame bolt.  
*Torque* : 184 lb.ft (250 Nm)
2. Tighten the lower control arm-to-wheel knuckle bolt.  
*Torque* : 203 lb.ft (275 Nm)

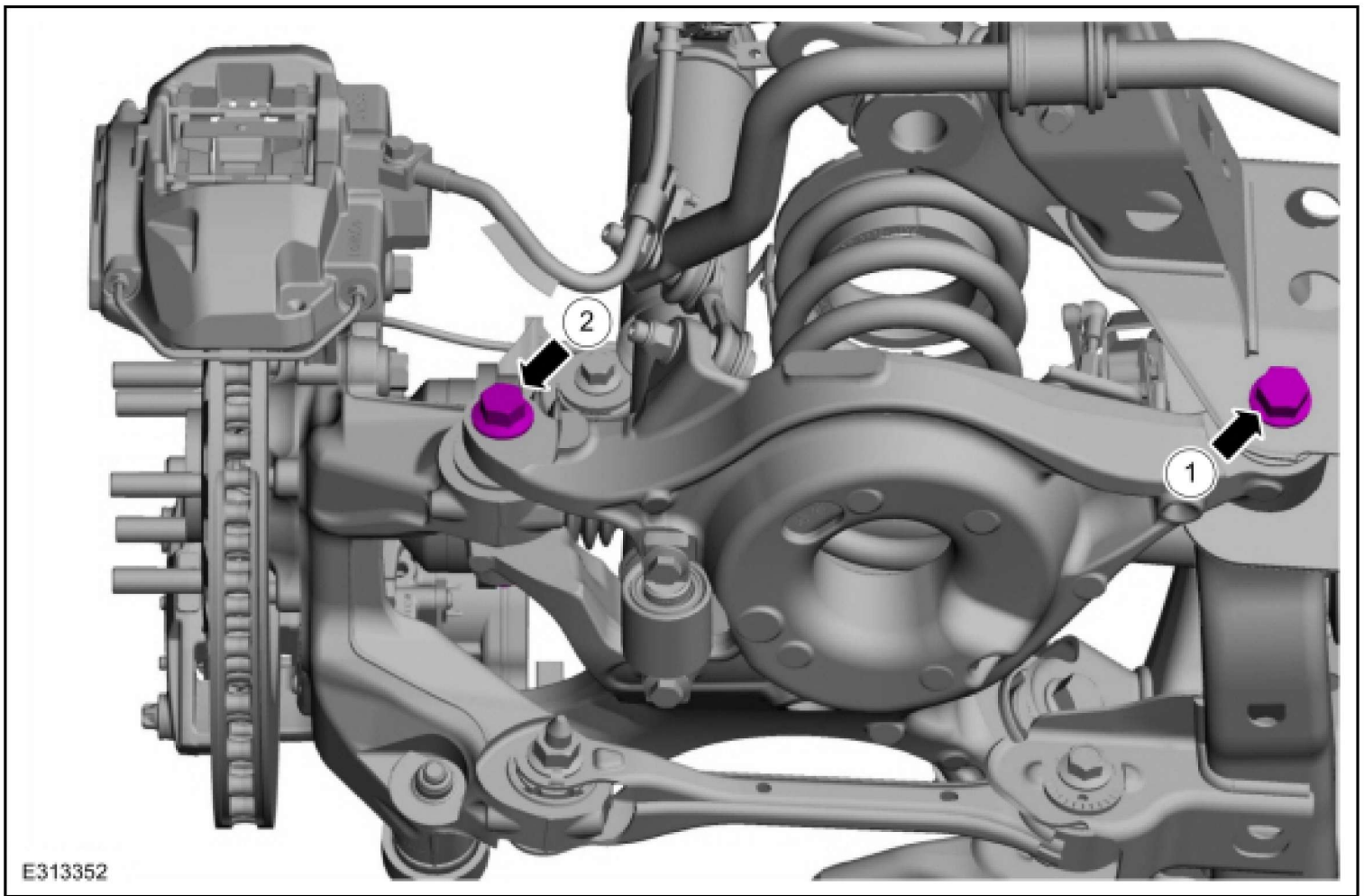

13. **NOTICE:** Tighten the suspension bushing fasteners with the suspension loaded or with the weight of the vehicle resting on the wheels and tires, otherwise incorrect clamp load and bushing damage may occur.

Tighten the forward lower control arm-to-frame bolt.  
*Torque* : 166 lb.ft (225 Nm)

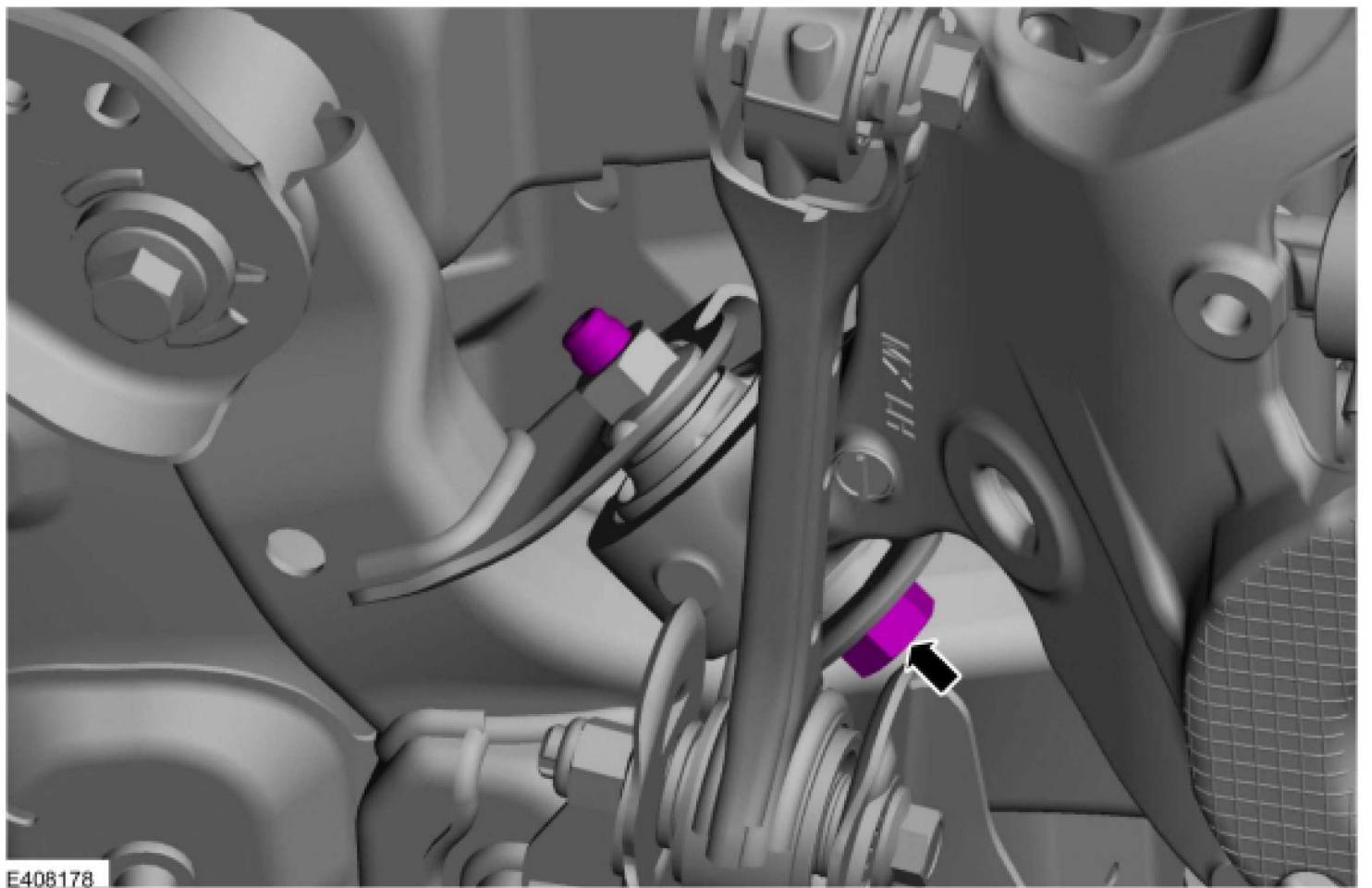

14. **NOTICE:** Tighten the suspension fasteners with the weight of the vehicle on the wheels and tires or use a suitable jack to raise the suspension to curb height or damage to the bushings may occur.

1. Tighten the lower arm vertical link upper bolt.  
*Torque* : 129 lb.ft (175 Nm)
2. Tighten the new toe link-to-knuckle bolt.  
*Torque* : 129 lb.ft (175 Nm)

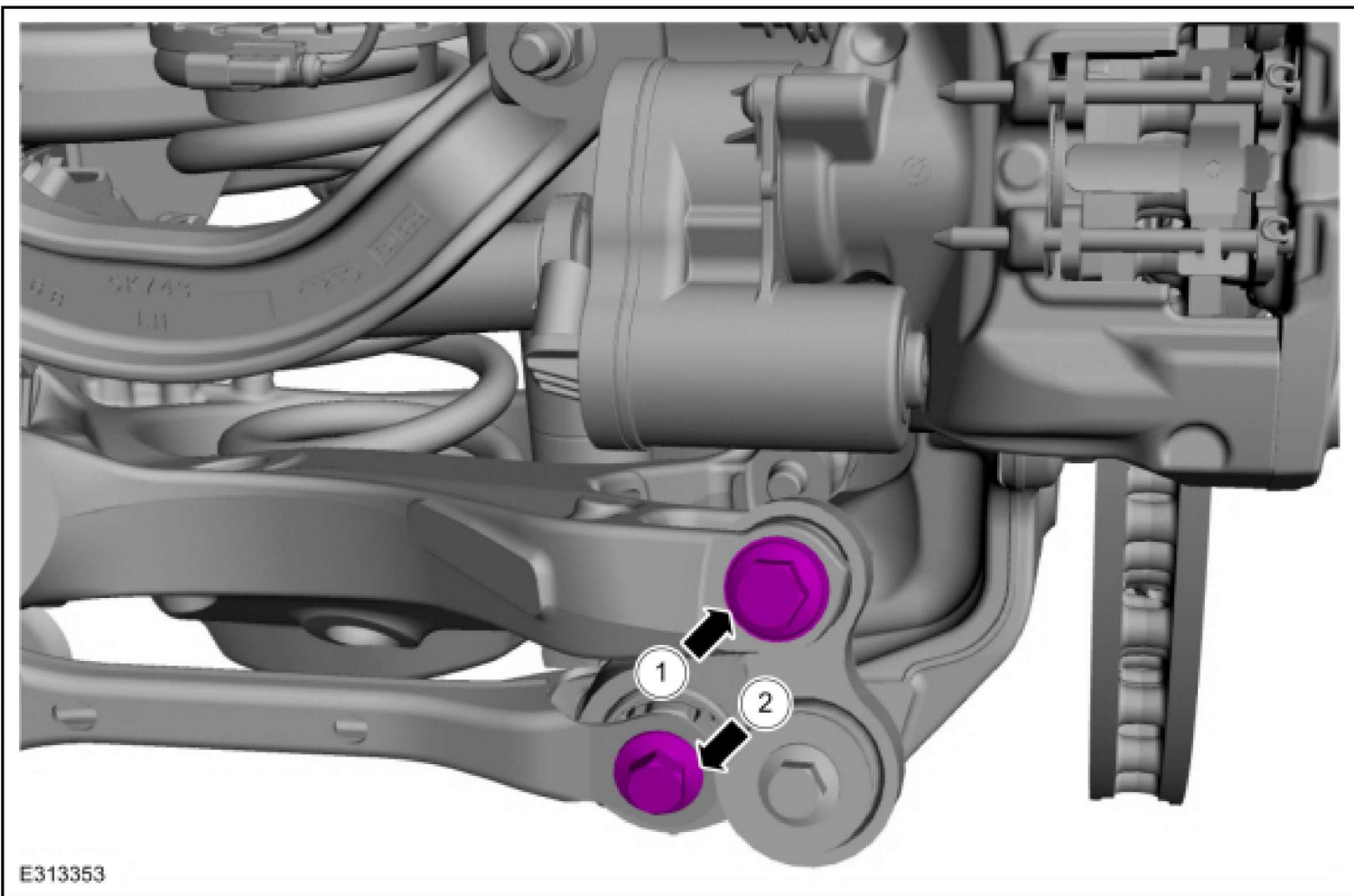

15. **NOTICE:** Tighten the suspension fasteners with the weight of the vehicle on the wheels and tires or use a suitable jack to raise the suspension to curb height or damage to the bushings may occur.

Tighten the new stabilizer bar link nut.  
*Torque* : 85 lb.ft (115 Nm)

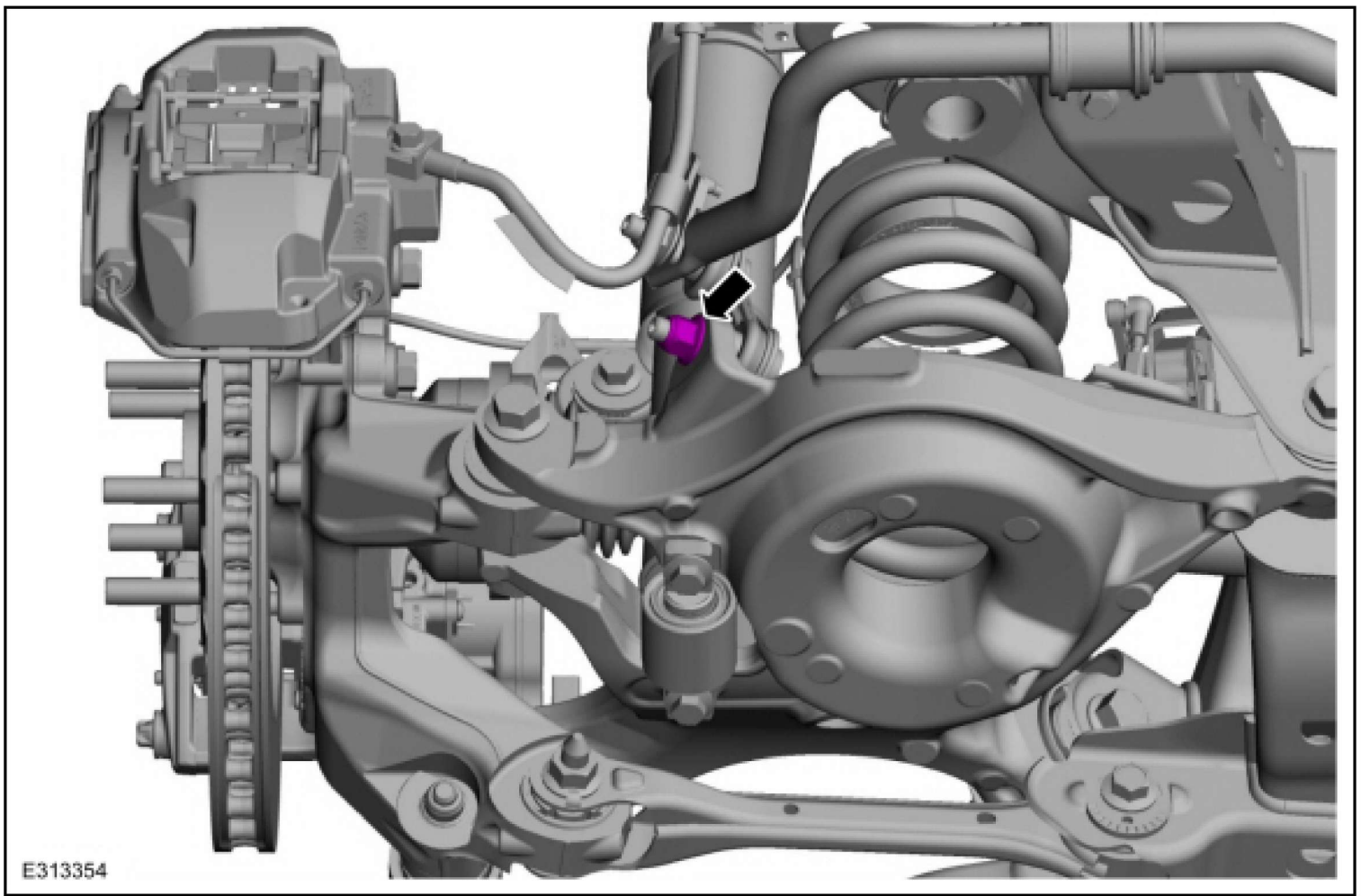

16. Install the wheel and tire.

Refer to: [Wheel and Tire](#) (204-04A Wheels and Tires, Removal and Installation) .

17. Check and if necessary, adjust rear camber.

Refer to: [Rear Camber Adjustment](#) (204-00 Suspension System - General Information, General Procedures) .

18. If equipped with dynamic suspension, calibrate the suspension system. Connect the scan tool and carry out the Ride Height Calibration routine. Follow the scan tool directions.

© Copyright 2025, Ford Motor Company.

---



# Lower Arm Vertical Link



## Special Tool(s) / General Equipment

Vehicle/Axle Stands
------------------------

## Removal

**NOTICE:** Suspension fasteners are critical parts that affect the performance of vital components and systems. Failure of these fasteners may result in major service expense. Use the same or equivalent parts if replacement is necessary. Do not use a replacement part of lesser quality or substitute design. Tighten fasteners as specified.

1. Remove the wheel and tire.  
Refer to: [Wheel and Tire](#) (204-04A Wheels and Tires, Removal and Installation) .
2. Support the suspension at curb height.  
Use the General Equipment: Vehicle/Axle Stands

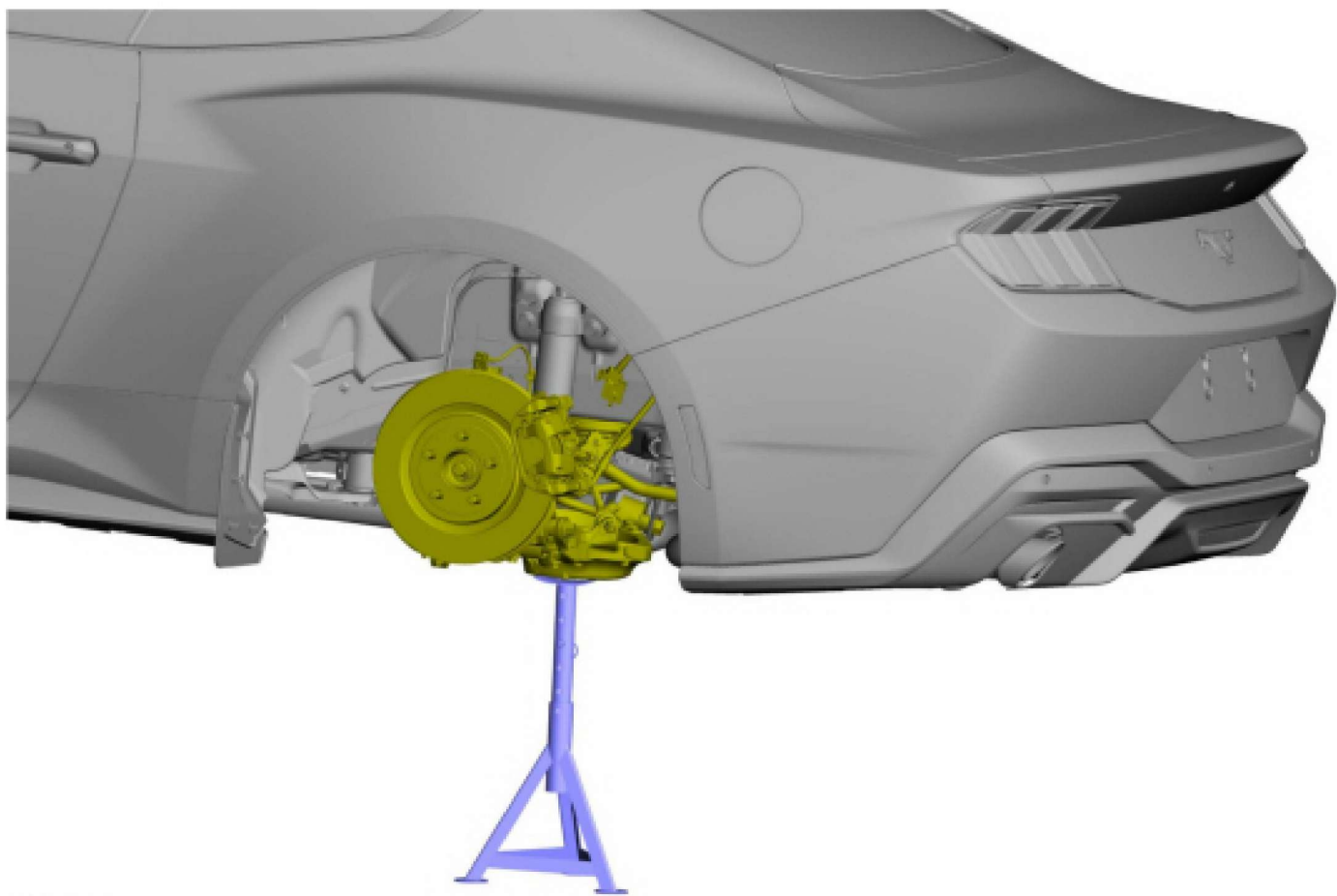

E408028

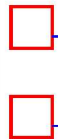

3.
  1. Remove and discard the lower arm vertical link upper bolt and retainer.
  2. Remove and discard the lower arm vertical link lower bolt and remove the lower arm vertical link.

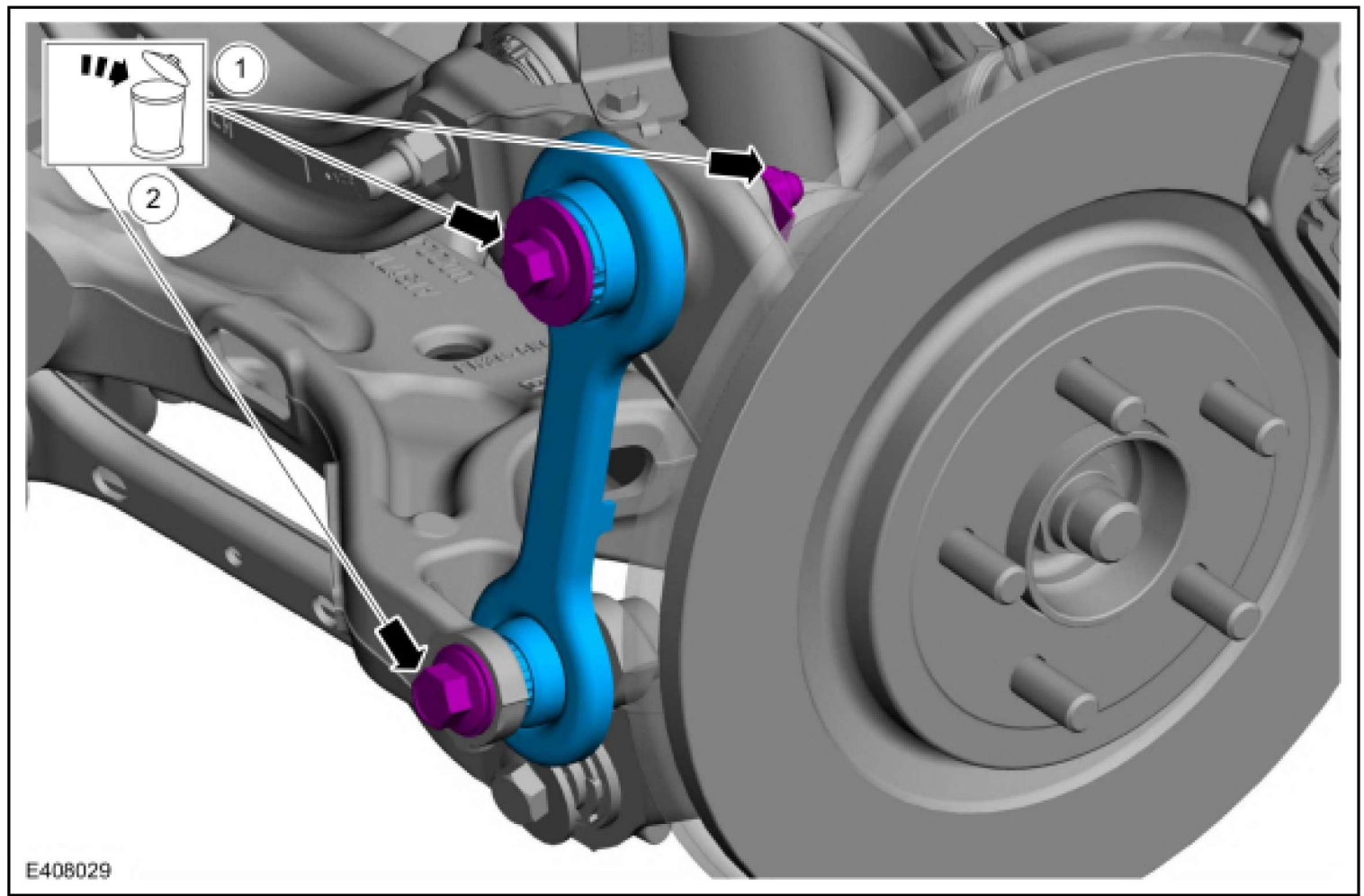

## Installation

**NOTICE:** Tighten the suspension bushing fasteners with the suspension loaded or with the weight of the vehicle resting on the wheels and tires, otherwise incorrect clamp load and bushing damage may occur.

1. Position the lower arm vertical link and install the new lower arm vertical link bolts.
  1. Tighten the lower arm vertical link upper bolt.  
*Torque : 76 lb.ft (103 Nm)*
  2. Tighten the lower arm vertical link lower bolt.  
*Torque : 129 lb.ft (175 Nm)*

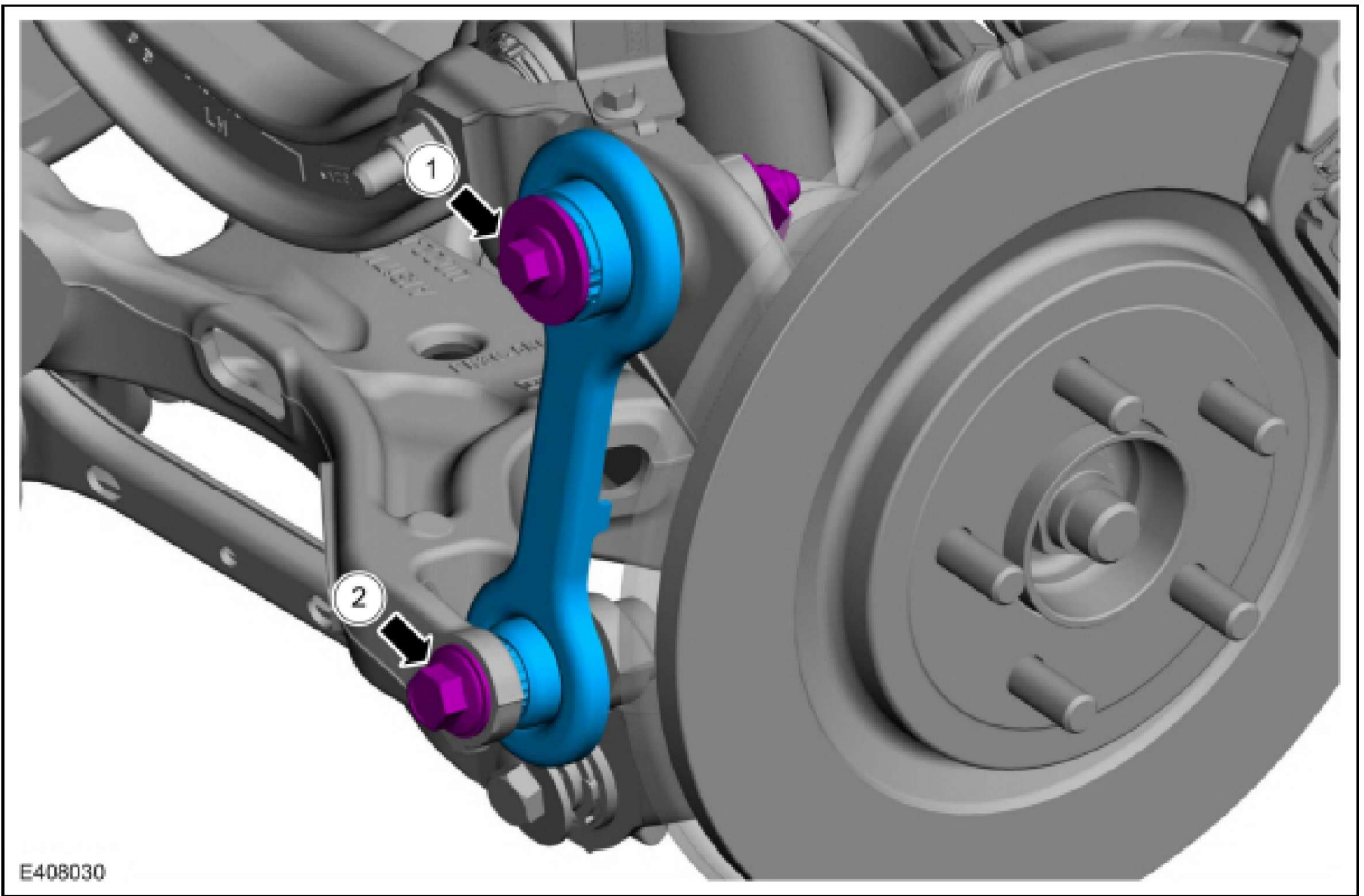

2. Install the wheel and tire.

Refer to: [Wheel and Tire](#) (204-04A Wheels and Tires, Removal and Installation) .

© Copyright 2025, Ford Motor Company.



# Lower Arm Vertical Link - Dark Horse/GT



## Special Tool(s) / General Equipment

Vehicle/Axle Stands
------------------------

## Removal

**NOTICE:** Suspension fasteners are critical parts that affect the performance of vital components and systems. Failure of these fasteners may result in major service expense. Use the same or equivalent parts if replacement is necessary. Do not use a replacement part of lesser quality or substitute design. Tighten fasteners as specified.

1. Remove the wheel and tire.  
Refer to: [Wheel and Tire](#) (204-04A Wheels and Tires, Removal and Installation) .
2. Support the suspension at curb height.  
Use the General Equipment: Vehicle/Axle Stands

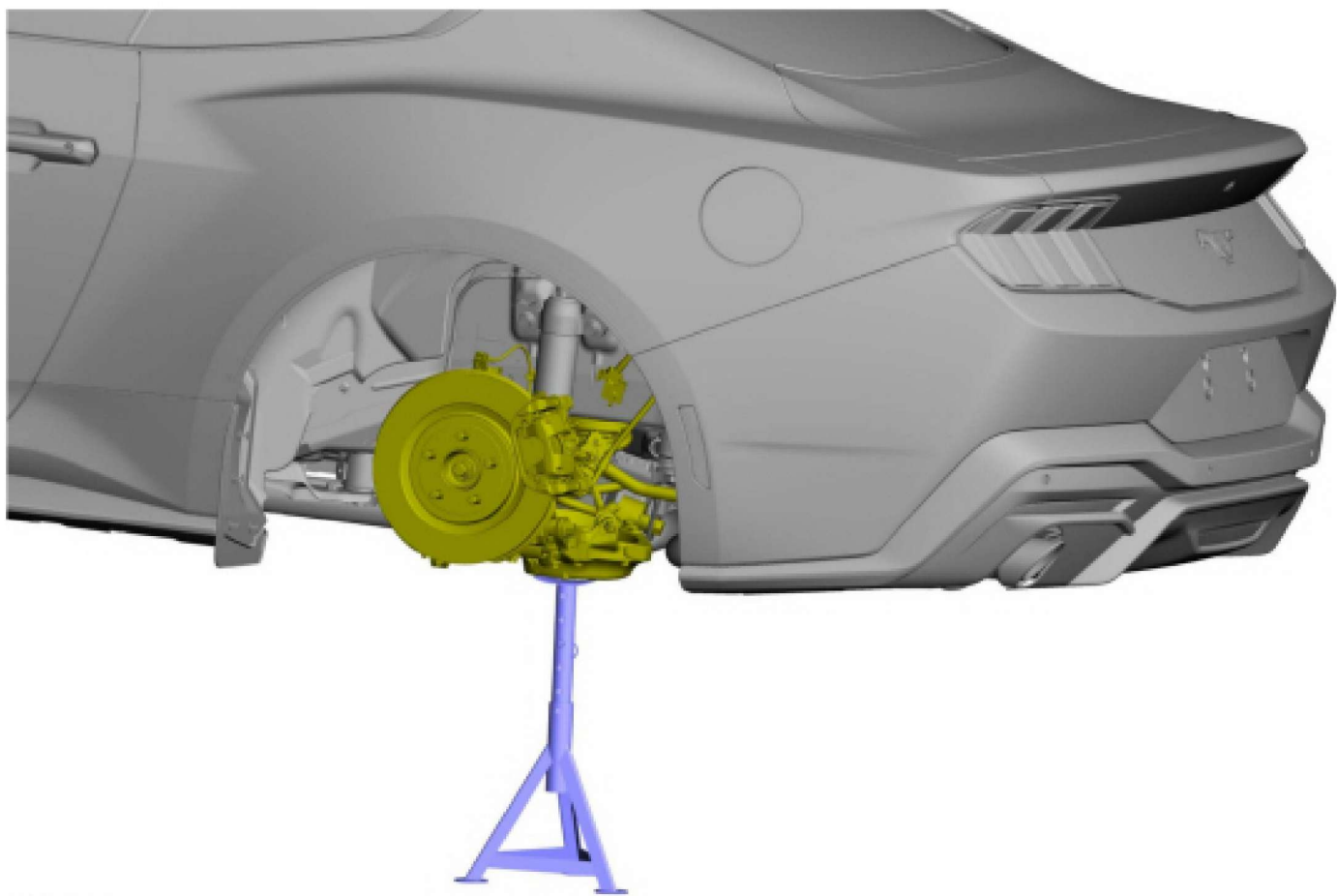

E408028

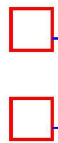

3. Remove and discard the lower arm vertical link upper and lower bolts and nut and remove the lower arm vertical link.

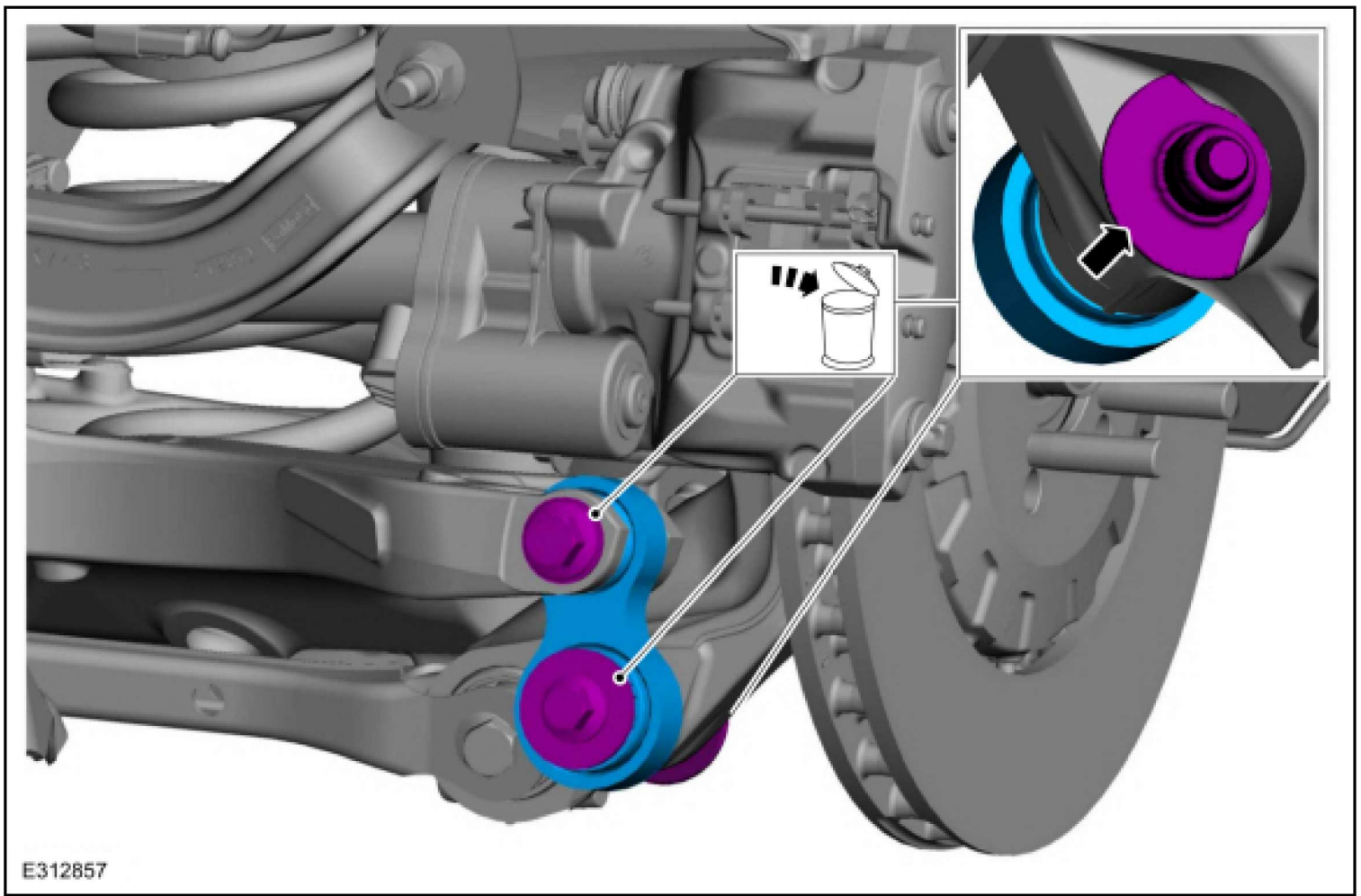

## Installation

**NOTICE:** Tighten the suspension fasteners with the weight of the vehicle on the wheels and tires or use a suitable jack to raise the suspension to curb height or damage to the bushings may occur.

1. Position the lower arm vertical link and install the new lower arm vertical link bolts.
  1. Tighten the new lower arm vertical link upper bolt.  
*Torque* : 129 lb.ft (175 Nm)
  2. Tighten the new lower arm vertical link lower bolt and nut.  
*Torque* : 76 lb.ft (103 Nm)

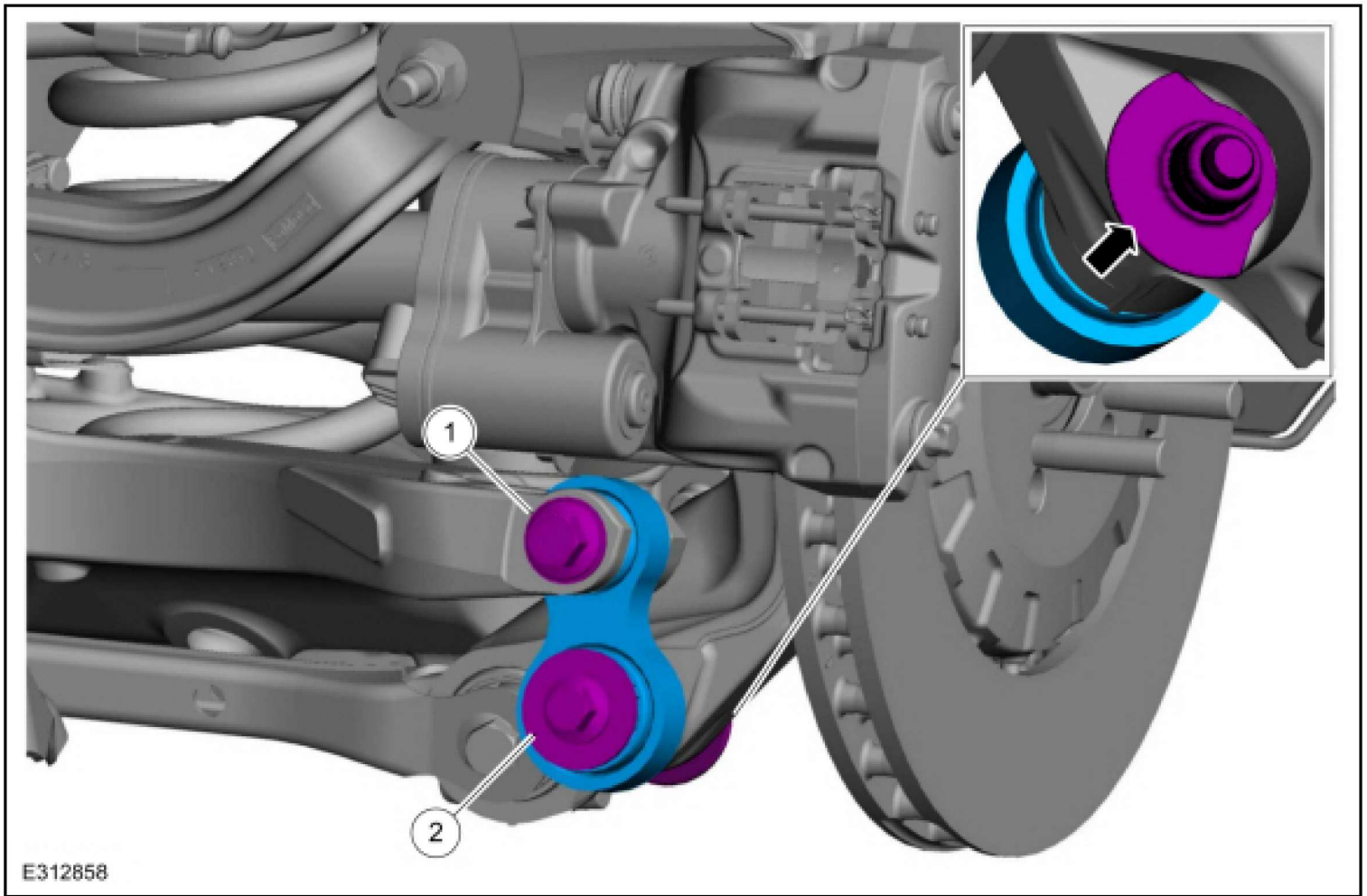

2. Install the wheel and tire.

Refer to: [Wheel and Tire](#) (204-04A Wheels and Tires, Removal and Installation) .

© Copyright 2025, Ford Motor Company.



# Rear Shock Absorber



## Special Tool(s) / General Equipment

Vehicle/Axle Stands
------------------------

## Removal

### All vehicles

**NOTICE:** Suspension fasteners are critical parts that affect the performance of vital components and systems. Failure of these fasteners may result in major service expense. Use the same or equivalent parts if replacement is necessary. Do not use a replacement part of lesser quality or substitute design. Tighten fasteners as specified.

1. Remove the wheel and tire.  
Refer to: [Wheel and Tire](#) (204-04A Wheels and Tires, Removal and Installation) .
2. Support the rear suspension.  
Use the General Equipment: Vehicle/Axle Stands

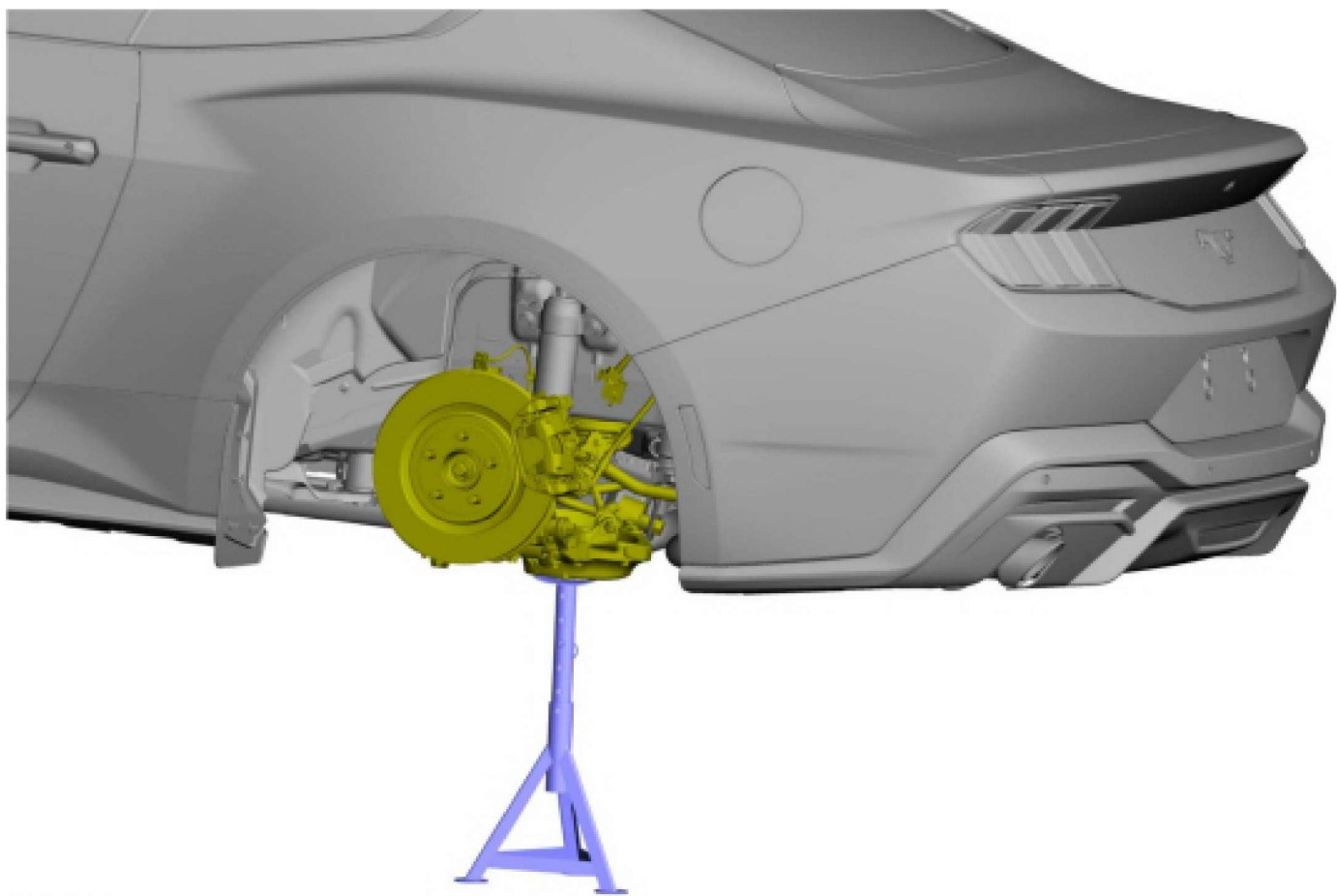

E408028

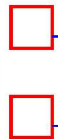

### **Vehicles equipped with dynamic suspension**

3. Disconnect the rear shock absorber electrical connector.

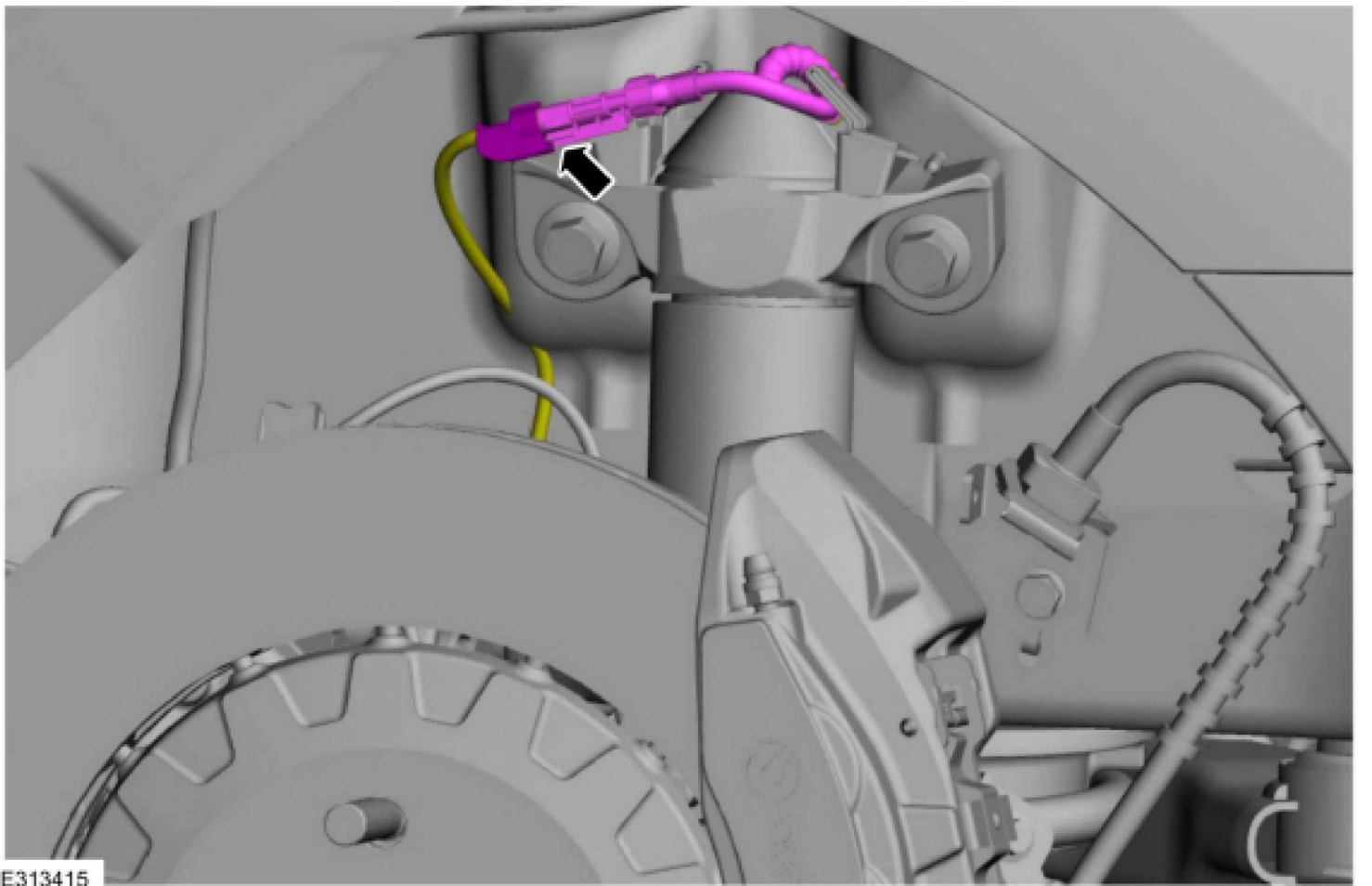

4. Remove and discard the rear shock absorber lower bolts.

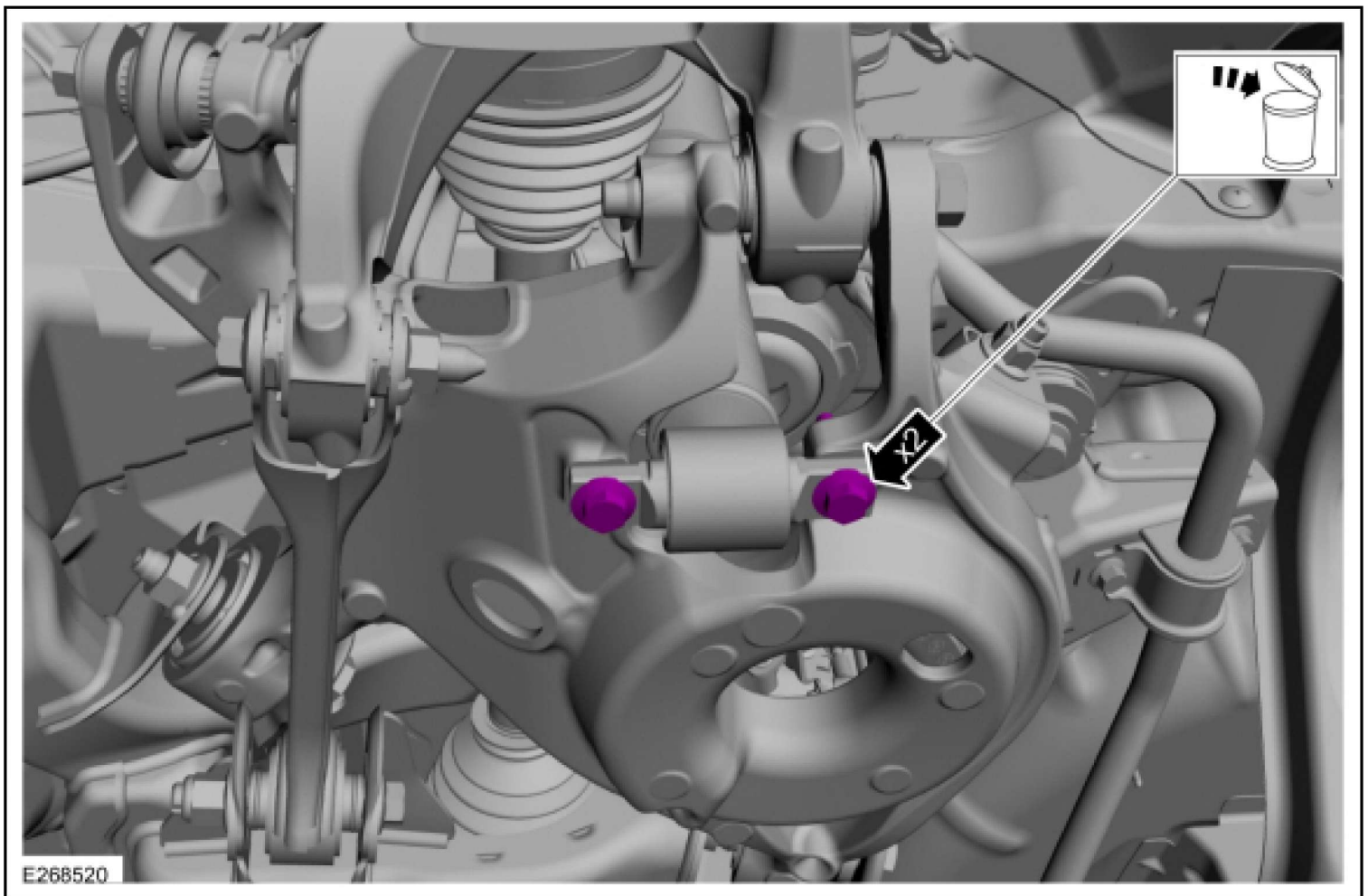

5. Remove and discard the rear shock absorber upper bolts and remove the rear shock absorber.

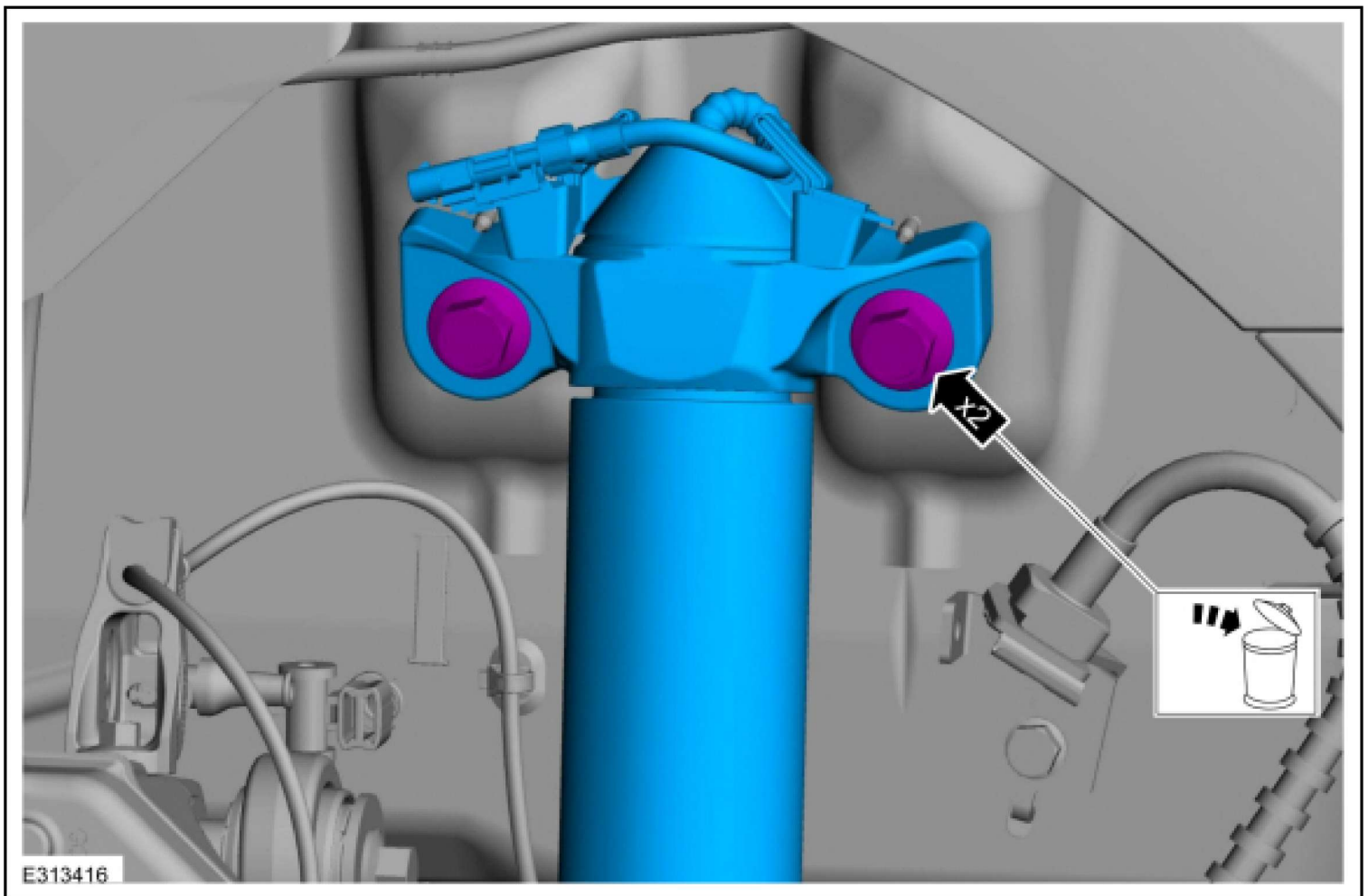

6. **NOTE:** *This step is only necessary when installing a new component.*

**NOTE:** *If equipped.*

Remove the rear shock absorber rod nut cap.

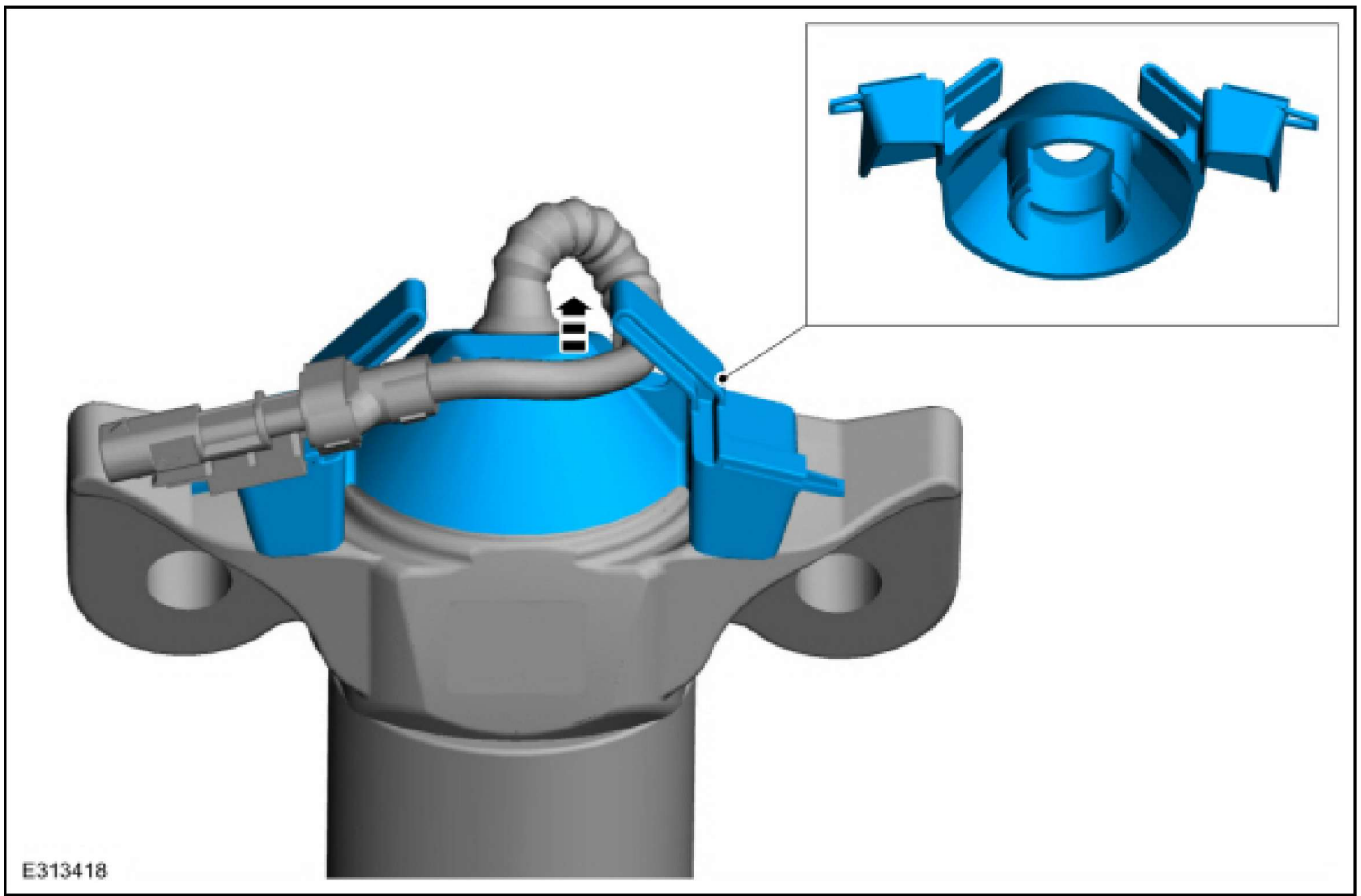

**7. NOTICE: Do not use power tools to remove the nut.**

**NOTE:** *This step is only necessary when installing a new component.*

**NOTE:** *Use the hex-holding feature to prevent the shock absorber rod from turning while removing the shock absorber rod nut.*

Remove and discard the rear shock absorber rod nut.

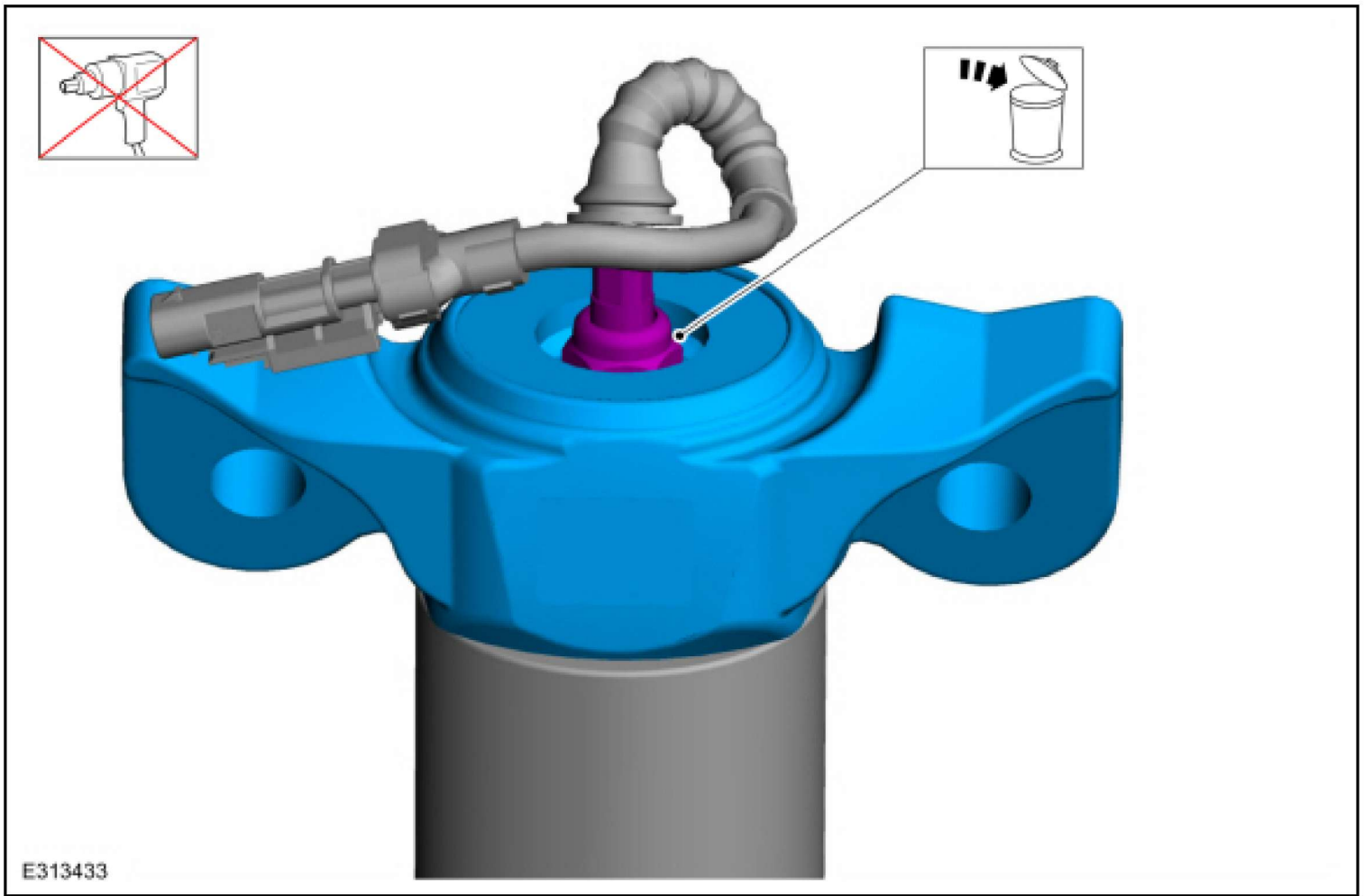

**All vehicles**

8. Remove and discard the rear shock absorber lower bolts.